

GPSMAP 392/398 **GPSMAP 492/498**

chartplotter receiver



GPSMAP 498 shown

© Copyright 2006 Garmin Ltd. or its subsidiaries

Garmin International, Inc.
1200 East 151st Street,
Olathe, Kansas 66062, USA
Tel. 913/397.8200 or 800/800.1020
Fax 913/397.8282

Garmin (Europe) Ltd.
Unit 5, The Quadrangle, Abbey Park Industrial Estate,
Romsey, SO51 9DL, UK
Tel. +44 (0) 870.8501241 (outside the UK)
0808 2380000 (UK only)
Fax 44/0870.8501251

Garmin Corporation
No. 68, Jangshu 2nd Road, Shijr, Taipei County,
Taiwan
Tel. 886/2.2642.9199
Fax 886/2.2642.9099

All rights reserved. Except as expressly provided herein, no part of this manual may be reproduced, copied, transmitted, disseminated, downloaded or stored in any storage medium, for any purpose without the express prior written consent of Garmin. Garmin hereby grants permission to download a single copy of this manual onto a hard drive or other electronic storage medium to be viewed and to print one copy of this manual or of any revision hereto, provided that such electronic or printed copy of this manual must contain the complete text of this copyright notice and provided further that any unauthorized commercial distribution of this manual or any revision hereto is strictly prohibited.

Information in this document is subject to change without notice. Garmin reserves the right to change or improve its products and to make changes in the content without obligation to notify any person or organization of such changes or improvements. Visit the Garmin Web site (www.garmin.com) for current updates and supplemental information concerning the use and operation of this and other Garmin products.

Garmin®, GPSMAP®, AutoLocate®, UltraScroll®, TracBack®, BlueChart®, MapSource®, and BlueChart® g2™ are registered trademarks of Garmin Ltd. or its subsidiaries and may not be used without the express permission of Garmin.

INTRODUCTION

Thank you for choosing the Garmin® GPSMAP® 392/398/492/498. The GPSMAP 392/398/492/498 utilizes the proven performance of Garmin GPS and full-featured mapping to create an unsurpassed portable GPS receiver. Take a moment now to compare the contents of this package with the packing list on the outside of the box. If any pieces are missing, contact your Garmin dealer immediately.

Before you begin working with the GPSMAP 392/398/492/498, review the installation instructions listed in the Appendix. If you have any question about installing your chartplotter, contact Garmin Product Support or a professional installer.

The GPSMAP 392/398/492/498 Sounder is CANet compatible. See the CANet accessory installation instructions for more information.

About This Manual

To get the most out of your new navigation system, take time to read this manual and learn the operating procedures for your unit in detail. This manual is organized into the following sections.

The **Introduction** section contains the Table of Contents as well as GPSMAP 392/398/492/498 care information.

The **Basic Operation** section provides you with detailed information and step-by-step directions for features such as using the Find Menu, navigating a route, and using waypoints.

The **Main Pages** section provides detailed explanations about each page in the GPSMAP 392/398/492/498 and step-by-step directions on using the pages.

The **Main Menu** section provides detailed explanations about the Main Menu and how to use it to configure your unit.

The **Using Sonar** section provides detailed explanations about the Sonar and Flasher Pages and how to configure your sonar options.

The **Appendix** contains installation instructions, specifications, optional accessories, and maintenance information. You can also find warranty and FCC information in the Appendix.

An **Index** is provided at the end of the manual for reference.

Manual Conventions

This manual uses the term **Warning** to indicate a potentially hazardous situation, which, if not avoided, could result in death or serious injury.

This manual uses the term **Caution** to indicate a potentially hazardous situation, which, if not avoided, may result in minor injury or property damage.

Table of Contents

Introduction.....	i
About This Manual	i
Manual Conventions	i
Warning	iv
Caution	v
Care Information.....	vi
Basic Operation	1
Initializing the Receiver	1
Simulator Mode	3
Adjusting the Backlight	4
Interface Keys.....	5
Entering Data and Selecting Options	6
Using the Map Pointer	7
Creating and Using Waypoints	8
Man OverBoard (MOB).....	10
Reviewing and Editing Waypoints	11
Navigating to a Destination	12
Creating and Using Routes	17
Find	19
Additional Information	21
DSC (Digital Selective Calling).....	21
AIS	25

Main Pages.....	26
Map Page.....	27
Compass Page.....	32
3D Highway Page	33
Active Route Page.....	36
Main Menu	37
GPS Tab.....	37
Tide Tab	40
Trip Tab.....	44
Celes (Celestial) Tab	45
Points Tab	46
Route Tab	51
Track Tab	57
DSC Tab.....	59
Card Tab	59
Msgs Tab	60
Pages Tab.....	61
Map Tab	61
Hiway (Highway) Tab.....	64
Temp (Temperature) Tab	64
Sonar Tab	64
System (System) Tab	65
Alarm Tab	70

Using Sonar	72	What is WAAS/EGNOS?.....	96
Understanding Sonar	72	What is a Maritime Mobile Service Identity (MMSI)?	97
Sonar Tab Options	79	How ARE MMSI assignments obtained?	97
Flasher Page	84	Navigation Terms	98
Map Split Page	85	Messages and Alarms	100
Appendix	86	LORAN TD System	103
Specifications	86	Optional Accessories	105
Installing the GPSMAP 492/498 External GPS Antenna.....	87	Software License Agreement	106
Mounting the GPSMAP 392/398/492/498	88	Product Registration	106
Installing the Transducer	90	Limited Warranty	107
Connecting the Power/Data Cable	92	FCC Compliance	108
Interfacing	93	Declaration of Conformity (DoC)	108
Installing and Removing Data Cards	94	Index	109
Satellite Information.....	95		

 **Warning**

Failure to avoid the following potentially hazardous situations could result in an accident or collision resulting in death or serious injury.

When navigating, carefully compare information displayed on the GPSMAP 392/398/492/498 to all available navigation sources, including information from visual sightings, and maps. For safety, always resolve any discrepancies or questions before continuing navigation.

Use the electronic chart in the GPSMAP 392/398/492/498 only to facilitate, not to replace, the use of authorized government charts. Official government charts and notices to mariners contain all information needed to navigate safely.

WARNING: This product, its packaging, and its components contain chemicals known to the State of California to cause cancer, birth defects, or reproductive harm. This Notice is being provided in accordance with California's Proposition 65. If you have any questions or would like additional information, please refer to our Web site at <http://www.garmin.com/prop65>.



Caution

Failure to avoid the following potentially hazardous situations may result in injury or property damage.

Use the GPSMAP 392/398/492/498 only as a navigational aid. Do not attempt to use the GPSMAP 392/398/492/498 for any purpose requiring precise measurement of direction, distance, location, or topography. The Global Positioning System (GPS) is operated by the United States

government, which is solely responsible for its accuracy and maintenance. The government's system is subject to changes which could affect the accuracy and performance of all GPS equipment, including the GPSMAP 392/398/492/498. Although the GPSMAP 392/398/492/498 is a precision navigation device, any navigation device can be misused or misinterpreted and, therefore, become unsafe.

Map Data Information: One of the goals of Garmin is to provide customers with the most complete and accurate cartography that is available to us at a reasonable cost. We use a combination of governmental and private data sources, which we identify in product literature and copyright messages displayed to the consumer. Virtually all data sources contain inaccurate or incomplete data to some extent. In some countries, complete and accurate map information is either not available or is prohibitively expensive.



- LAMP(S) INSIDE THIS PRODUCT MAY CONTAIN MERCURY AND MUST BE RECYCLED OR DISPOSED OF ACCORDING TO LOCAL, STATE, OR FEDERAL LAWS.

The California Electronic Waste Recycling Act of 2003 requires the recycling of certain electronics. For more information on the applicability to this product, see www.erecycle.org.

Care Information

Cleaning the Unit

The GPSMAP 392/398/492/498 is constructed of high quality materials and does not require user maintenance other than cleaning. Clean the unit using a cloth dampened with a mild detergent solution and then wipe dry. Avoid chemical cleaners and solvents that can damage plastic components.

Storing the GPSMAP 392/398/492/498

Do not store the GPSMAP 392/398/492/498 where prolonged exposure to temperature extremes can occur (such as in the trunk of a car) as permanent damage can result. User information, such as waypoints and routes are retained in the unit's memory without the need for external power. It is always a good practice to back up important user data by manually recording it or downloading it to a PC (transferring it to MapSource.)

Immersing the Unit in Water

The GPSMAP 392/398/492/498 is waterproof to IEC Standard 60529 IPX7. It can withstand immersion in 1 meter of water for 30 minutes. Prolonged submersion can cause damage to the unit. After submersion, be certain to wipe and air dry the unit before reuse.

To resolve problems that cannot be remedied using this manual, contact Garmin Product Support in the U.S. at 800/800-1020 or Garmin Europe at 44/0870-8501241.

BASIC OPERATION

Initializing the Receiver

The first time you turn on the GPSMAP 392/398/492/498, the receiver must be given an opportunity to collect satellite data and establish its present location. To ensure proper initialization, the GPSMAP 392/398/492/498 is shipped from the factory in AutoLocate Mode.

Before you initialize, make sure the GPSMAP 392/398/492/498 unit and antenna are correctly installed on your vessel according to the instructions in the “Appendix.” Install the antenna in a location with a clear and unobstructed view of the sky.

A full-screen GPS Information Page is shown after you press **ENTER** to acknowledge the Warning Page. The page goes away after the unit gets a position fix, or you press either **ENTER** or **QUIT**.

To turn on the GPSMAP 392/398/492/498:

1. Press and hold the **POWER** key until the power tone sounds, then release the **POWER** key. The title page, and then the Warning Page appears while the unit conducts a self-test.
2. When the self-test is complete, press **ENTER** to agree and acknowledge the warning.

3. Press **ENTER** to answer **NO** to the window asking “Do you want to start the Retail Demonstration?”. You are only asked this the first time you start the unit.

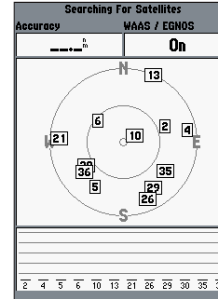

The GPS Information Page appears as the receiver begins acquiring satellites.

To turn off the GPSMAP 392/398/492/498:

1. Press and hold the **POWER** key.
2. When the screen is blank, release the **POWER** key.

To graphically initialize the GPSMAP 392/398/492/498:

1. Press and hold **ADJ/MENU** for the Main Menu. Press up or down on the **ROCKER** until the **GPS** tab is highlighted, and then press **ADJ/MENU** once.
2. Using the **ROCKER**, highlight **Initialize Position**, and press **ENTER**. The Initialize Position Page appears, prompting you to select your approximate location with the map pointer.

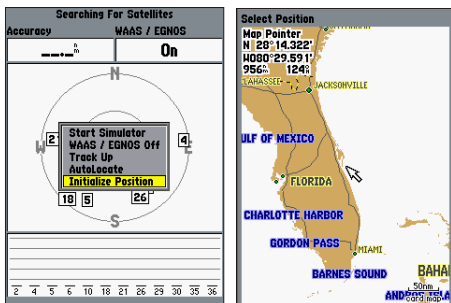

3. Use the **ROCKER** to move the map pointer to your approximate location within 200 miles. If you have difficulty identifying your location, press and release the **RANGE Down** key to see the next lower map range.

4. After you have determined your approximate location on the map, press **ENTER**.



NOTE: This does not calibrate the unit in any way, rather it helps to speed up the initial satellite acquisition. If the unit shows “Ready for Navigation” during this process, it is not necessary to initialize the unit.

The unit now begins searching for the appropriate satellites for your region and should acquire a fix within a few minutes. When viewing the GPS tab on the Main Menu, a signal strength bar for each satellite in view appears on the bottom of the page, with the appropriate satellite number under each bar.

- **No signal strength bars**—the receiver is looking for the satellites indicated.
- **Hollow signal strength bars**—the receiver has found the indicated satellite(s) and is collecting data.
- **Solid signal strength bars**—the receiver is ready to use.

When the receiver has collected information from at least three satellites, the top of the screen shows either “Ready for Navigation”, and the GPSMAP 392/398/492/498 is ready for use.

Simulator Mode

Simulator Mode turns the GPS receiver off for use indoors or practice. You can perform any of the functions discussed in the following pages in Simulator Mode. Keep in mind that the GPSMAP 392/398/492/498 does not track satellites in Simulator Mode, and this mode should never be used for actual navigation. All the waypoint and route planning completed in Simulator Mode is retained in memory for future use.



WARNING: Do not attempt to navigate using Simulator Mode. When the unit is set to Simulator Mode, the GPS receiver is turned off. Any satellite signal strength bars shown are only simulations and do not represent the strength of actual satellite signals.

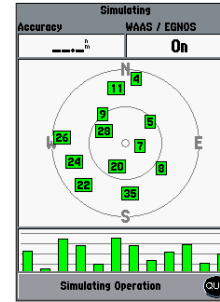

To place the GPSMAP 392/398/492/498 in Simulator Mode:

1. Press and hold **ADJ/MENU** to show the Main Menu. Use the **ROCKER** to highlight the **GPS** tab, and then press **ADJ/MENU** once.
2. Use the **ROCKER** to highlight **Start Simulator**, and press **ENTER**.
3. Press **QUIT** to confirm the **Running Simulator** message that appears at the bottom of the screen. If the status bar is turned on, “Simulating” appears at the top of each of the main pages.
4. To turn off Simulator Mode, press **ADJ/MENU**, and select **Stop Simulator**.

The Set Position, Track Control, Track and Speed fields only show while in Simulator Mode.



To enter a simulated speed and heading from the Main Menu:

1. Press and hold **ADJ/MENU** to show the **Main Menu**.
2. Use the **ROCKER** to highlight the **System** tab, and then highlight the **Setup** button next to the Simulator field on the **General** sub tab. Press **ENTER**.
3. Highlight the **Speed** field, and then press **ENTER**. Use the **ROCKER** to enter a speed, and press **ENTER**.
4. Use the **ROCKER** to highlight **Track Control**. Press **ENTER**, and select **User Track**.
5. Highlight the **Track** field, and press **ENTER**. Use the **ROCKER** to set the track.
6. Highlight **Set Position**, and press **ENTER** to change the simulated location.
7. Press **QUIT** until you return to the Map Page.

To adjust the simulated speed and heading from the Compass or 3D Highway Pages:

1. Press up on the **ROCKER** increase the speed in 10 knot/kph/mpH increments. Press down on the **ROCKER** to decrease the speed in the same increments.
2. Press left or right on the **ROCKER** to steer the boat.

Adjusting the Backlight

The adjustable screen backlighting is controlled with the **POWER** key, and can be adjusted from any page.



To adjust the backlighting:

1. Press and release the **POWER** key. The adjustment slider window appears.
2. Press the **POWER** key again and the user-defined level of backlighting starts. You can adjust this level by pressing up or down on the **ROCKER**. If you press **POWER** one more time, the backlight is at the maximum setting.
3. Press **ENTER** or **QUIT** when finished.

Interface Keys

POWER Key

- Press and hold to turn the unit on or off.
- Press and release to adjust backlighting.

PAGE Key

- Press to cycle through the main pages.
- Press to end an operation in progress and return to the main page.

QUIT Key

- Press and release to cancel data entry or exit a page.

ENTER/MARK Key

- Press and release to enter highlighted options and data or confirm on-screen messages.
- Press and hold at any time to mark your current location as a waypoint.

DATA/CNFG Key

- Press to toggle the display of a main page with or without data fields.
- Press and hold to show the Main Page Configuration window.



RANGE Down/RANGE Up Keys

- From the Map Page, press to zoom in or out.
- From the Sonar Page, press to scroll up or down the range list.

ROCKER Key

- Press up, down, right, or left to move through lists, highlight fields, on-screen buttons and icons, enter data, or move the map pointer.

ADJ/MENU Key

- Press and release to view options for a page.
- Press and hold to view the Main Menu.

NAV/MOB Key

- Press and release at any time to view the Navigation Menu.
- Press and hold for MOB waypoint.

FIND Key

- Press to search for points such as user waypoints, cities, and services.

Entering Data and Selecting Options

You can select and start options, and enter data to customize the GPSMAP 392/398/492/498 to fit your requirements. Use the **ENTER** key and the **ROCKER** to select options, enter names and numbers in data fields, and start your selections.

To select an optional feature:

1. With any page shown, press **ADJ/MENU** for the adjustment menu. The adjustment menu shows a list of optional features that are specific for that page. To select an option requires movement of the cursor. This is referred to as highlighting, selecting, or choosing an item.
2. Use the **ROCKER** to move the cursor (highlight) up and down a list or up, down, left, and right on menus.
3. After you highlight a selection, press **ENTER** to start the feature. Repeat this process to select an option from the list, or press **QUIT** to return to the previous setting.

To select an on-screen button:

Some pages contain on-screen buttons. Use the **ROCKER** to highlight an on-screen button, and press **ENTER**.

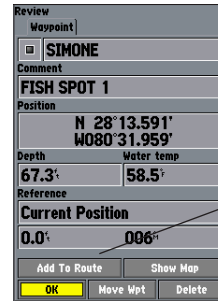

On-screen buttons

Using the Map Pointer

The map pointer is controlled by the **ROCKER**. You can pan to map locations, mark and edit waypoints and routes, and review position data of on-screen map items and waypoints. When you move the map pointer over a map item, a highlighted description of that item appears.

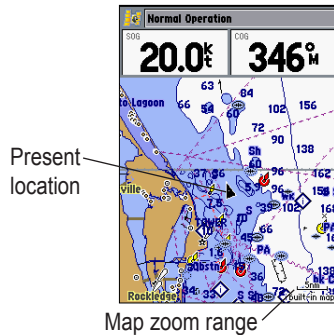

To pan the map:

1. Use the **RANGE Down/RANGE Up** keys to select a map zoom range.
2. Use the **ROCKER** to move the map pointer. A data field appears at the top of the screen showing the bearing and distance from your boat to the map pointer, along with the latitude/longitude of the map pointer.
3. Press **QUIT** to re-center your boat on the Map Page.

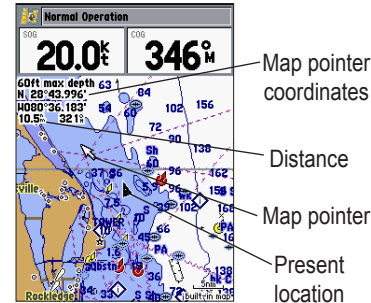

The Map Page actively scrolls or pans enabling you to explore areas around the world and create waypoints and routes. Press **QUIT** to return the map to your present location.



NOTE: When the map pointer reaches the edge of the map, the unit might pause as it loads new map data.

Creating and Using Waypoints

The GPSMAP 392/398/492/498 stores up to 3,000 alphanumeric waypoints with a user-defined symbol, comments, depth, and water temp, available for each waypoint. Waypoints can be created using two basic methods:

ENTER/MARK Key—marks your present location, and provides options to select a map location or map item from the Map Page. Also, you can enter a new waypoint's location coordinates manually.

Graphically—defines a new waypoint location from the Map Page using the **ROCKER**.

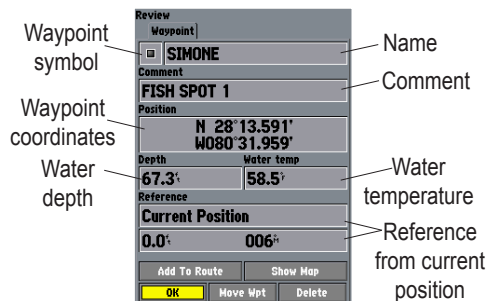

Waypoint Review Page

ENTER/MARK Key

Use the **ENTER/MARK** key to quickly capture your present location to create a new waypoint. The unit must have acquired at least three satellites to mark your present location. You can also use this option to manually enter waypoint coordinates.

To mark your present location:

1. Press and hold **ENTER/MARK** until the **New Waypoint** window appears. A default four-digit name and symbol are created for the new waypoint.
2. To accept the waypoint with the default name and symbol, highlight **OK**, and press **ENTER/MARK**.
3. To enter a different name, highlight the name field, and press **ENTER/MARK**. Use the **ROCKER** to enter the new alphanumeric name, and press **ENTER/MARK** when finished. You can use up to 10 characters for the name.
4. To select a different symbol, highlight the symbol field to the left of the name, and press **ENTER/MARK**. Use the **ROCKER** to highlight the new symbol, and press **ENTER/MARK**.

5. To enter optional comments or a depth, highlight the **Comments**, **Depth**, or **Water Temp**, and press **ENTER/MARK**, use the **ROCKER** to enter a value, and press **ENTER/MARK**.
6. To manually enter a set of coordinates, highlight the location coordinates, and press **ENTER/MARK**, use the **ROCKER** to enter the new coordinates, and press **ENTER/MARK** when finished.
7. Use the **ROCKER** to highlight **OK**. When finished, press **ENTER/MARK** to save the waypoint into memory.

Creating Waypoints Graphically

You create waypoints graphically from the Map Page. To mark a map location or map item, select the location or item with the map pointer, and press **ENTER**. When selecting a location or map item, a description of the point, its distance and bearing from your current location, and the latitude/longitude of the map pointer is shown along the top of the map.

To create a new waypoint graphically:

1. Use the **ROCKER** to move the map pointer to a map location. If you want to create the new waypoint at an on-screen map item, highlight the map item on the screen.
2. Press and release **ENTER/MARK** to capture the map pointer location. Do not hold the button down, doing so marks your present location, not the map location.
If you are not using a map item to create a waypoint, go to step 4.
3. Highlight **Create Wpt**, and press **ENTER/MARK**.
4. To accept the waypoint with the default name and symbol, press **ENTER/MARK**.
5. To change the name, symbol, or add a comment or depth, highlight the appropriate field, and press **ENTER/MARK**. Make your changes, and press **ENTER/MARK** when finished.
6. Highlight **OK**, and press **ENTER/MARK** to confirm the changes.

Man OverBoard (MOB)

The Man OverBoard function (MOB) simultaneously marks and sets a course back to the marked location for quick response to emergency situations.

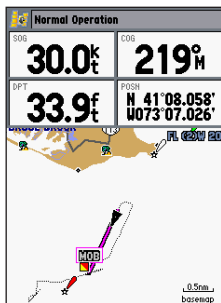

The MOB function allows you to quickly start navigation back to a location.

To start the MOB function:

1. Press and hold **NAV/MOB**.
2. Press **ENTER** to begin navigating to the **MOB** location.
3. To stop navigation to the **MOB** location, press **NAV**, highlight **Stop Navigation**, and press **ENTER**.

When a MOB is active, a MOB waypoint with an international MOB symbol is created and the unit is on an active navigation to that point. Use any of the Navigation Pages to guide you back to the MOB point. The MOB waypoint is stored in the waypoint list and works like any other waypoint.



To stop navigation, press **NAV/MOB** highlight **Stop Navigation**, and press **ENTER**.

Reviewing and Editing Waypoints

You can review, modify, rename, move, or delete waypoints at any time using the Waypoint Edit Page. The Waypoint Edit Page is available for any stored waypoint. Select the waypoint on the map or from the waypoint lists in the Main Menu—Points tab.

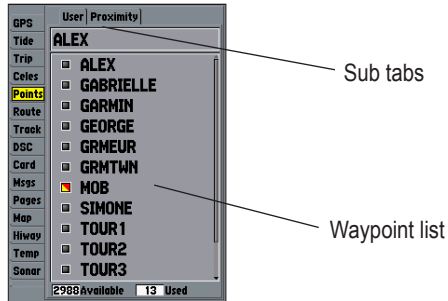

Sub tabs

Waypoint list

To access the Waypoint Edit Page:

1. Use the **ROCKER** to highlight the waypoint on the Map Page.
OR
Press and hold **ADJ/MENU**, highlight the **Points** tab, and choose a waypoint from the **User** or **Proximity** sub tabs.
2. Press **ENTER** to show the Waypoint Edit Page.

3. From the Waypoint Edit Page, change the name, symbol, comment, position coordinates, depth, or water temp for the selected waypoint. When finished, highlight **Next**, and press **ENTER** to save them. Press **QUIT** to cancel.

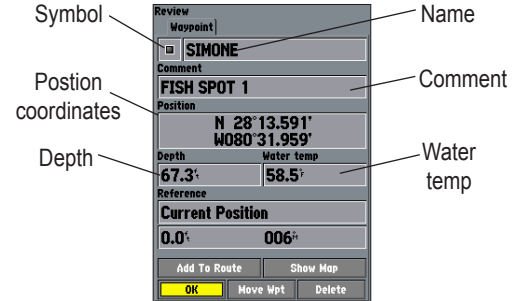

Waypoint Edit Page

To change the waypoint name:

1. Highlight the waypoint name field, and press **ENTER**.
2. Use the **ROCKER** to enter a new name, and press **ENTER** when finished.

To change the waypoint symbol:

1. Highlight the waypoint symbol field to the left of the waypoint name, and press **ENTER**.
2. Use the **ROCKER** to select a new symbol, and press **ENTER**.

To change the Comment, Location, Coordinates, Depth, or Water Temp:

1. Highlight a field, and press **ENTER**.
2. Use the **ROCKER** to edit or enter the data. To move to the next character, press right on the **ROCKER**.
3. Press **ENTER** when finished.

To move the waypoint on the map:

1. From the Waypoint Edit Page, highlight **Move Wpt**, and press **ENTER**. A **MOVE** label now appears under the map pointer in addition to a distance, bearing, and coordinate window. You can also use the **RANGE Down** and **RANGE Up** keys to zoom the map. The map zoom range appears in the lower-right corner.
2. Use the **ROCKER** to point to the new location, and press **ENTER**.
3. To stop the move process, press **QUIT**.

Navigating to a Destination***Using the Nav Key***

The **NAV** key provides four ways to navigate to a destination: Go To Point, Follow Route, Follow Track, and TracBack. When you are actively navigating, the Map Page shows a straight line from your current location to the destination. The Go To option is the easiest method for selecting a destination. A Go To allows you to select a destination point and quickly set a direct course from your present location. If you have a point highlighted on a list or the map, **Go To <point name>** appears in addition to **Go To Point**. The Go To function is accessed from any list of points or graphically from the Map Page.

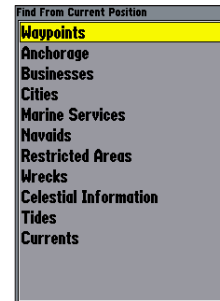

To start a Go To from a point list:

1. Press **NAV**. Highlight **Go To Point**, and press **ENTER**.
2. From the **Find** menu, highlight **Waypoints** or another menu option, and press **ENTER**.
3. To select a waypoint from the waypoint lists, use the **ROCKER** to highlight either the **By Name** or **Nearest** tab, select a waypoint, and press **ENTER**.

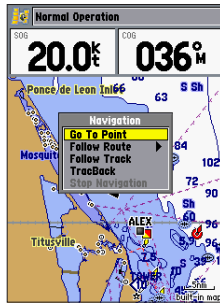
**Selecting a Go To Graphically**

A Go To can be used to select one of three items from the Map Page: an existing waypoint, an on-screen map item such as roads, rivers, cities, and nav aids, or a new map point. If you are selecting a map item as the Go To destination, the GPSMAP 392/398/492/498 automatically uses the name of the map item, but the point is not stored in the waypoint list. See [page 8](#) for creating waypoints using map items. If you are selecting a new map point (non-map item) as the Go To destination, the GPSMAP 392/398/492/498 automatically creates a waypoint at the map pointer location.

To Go To an existing waypoint or map item from the Map Page:

1. Use the **ROCKER** to highlight the waypoint or on-screen map item.
2. Press **NAV**. **Go To <waypoint name>** appears.
3. Press **ENTER** to start navigating to the waypoint.

To Go To a new map point (non-map item):

1. Use the **ROCKER** to move the map pointer to location.
2. Press **NAV**.
3. With **Go To MAP Point** highlighted, press **ENTER**.

***TracBack Navigation (Navigating a Track)***

The TracBack function retraces your path to the starting point using the track log automatically stored in the receiver's memory. This feature eliminates the need to store waypoints along the way. TracBack routes are created by reducing your track log into a route of up to 300 turns and activating an inverted route along those points. When started, a TracBack route leads you back to the oldest stored track log point, so it is a good idea to clear the existing track log before you start your current trip.

To clear the track log:

1. Press and hold **ADJ/MENU** to show the Main Menu.
2. Using the **ROCKER**, highlight the **Track** tab, and then highlight the **Active** sub tab.
3. Use the **ROCKER** to select the **Clear** button, and press **ENTER**.
4. Highlight **OK**, and press **ENTER**.

To save a track log:

1. From the Main Menu, use the **ROCKER** to highlight the **Track** tab, then highlight the **Active** sub tab to the right.
2. Use the **ROCKER** to select **Save**, and press **ENTER**.
3. From the **Save Back Through** window, highlight time, date, or Entire Log, and press **ENTER**. When the track is saved, the **Save Track** window appears. The default name, distance, number of points (700 max), and color are shown in the **Save Track** window.

To change the name of the saved track, highlight the name field, and press **ENTER**. Make your changes and press **ENTER**.

To show the track on the Map and 3D Highway Pages, highlight the check box to the left of **Show on map and highway**, and press **ENTER**.

To view the track on the map, highlight **Show Map**, and press **ENTER**.

4. Highlight **OK**, and press **ENTER** to save the track.

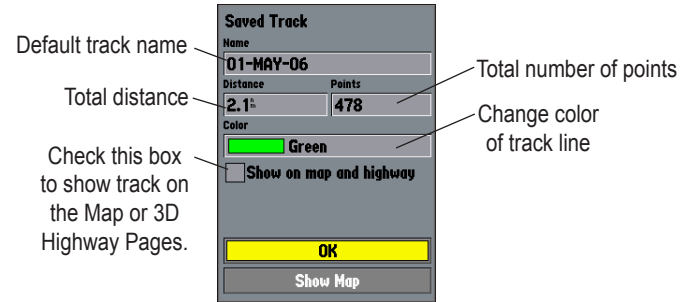

To start a TracBack using the NAV key:

1. Press **NAV**, highlight **TracBack**, and press **ENTER**.
2. To stop TracBack navigation, press **NAV**, highlight **Stop Navigation**, and press **ENTER**.

When a TracBack is active, the GPSMAP 392/398/492/498 takes the track log currently stored in memory and divides it into segments called legs. Up to 300 temporary turns (BEGIN, TURN 1, TURN 2, TURN 3, ..., TURN X, END) are created to mark the most significant features of the track log in order to duplicate your exact path as closely as possible. To get the most out of the TracBack feature, remember the following tips:

- Always clear the track log at the starting point.
- Set the Record Mode option on the track log setup page to **Fill** or **Wrap**.
- The track log memory must contain at least two points to create a TracBack route.
- If the track log interval is set to the **Time** option, the route can not follow your exact path. For best performance, keep the interval set to **Resolution**.
- If the receiver is turned off or satellite coverage is lost during your trip, the TracBack draws a straight line between any point where coverage was lost and where it resumed.

- If the track log's changes in distance and direction are too complex, 300 waypoints might not mark your path accurately. The receiver then assigns the 300 waypoints to the most significant points of your track, and simplifies segments with fewer changes in direction.

For more information on setting up the Track options and saved tracks, see [page 57](#).

Following a Track

The Following a Track function retraces a track from the beginning, the oldest time, to the end, the newest time. You can only use this function with Saved Tracks. To save a track, refer to the instructions on [page 15](#).

To Follow a Track:

1. Press **NAV**, highlight **Follow Track**, and press **ENTER**.
2. Highlight the track you want to follow, and press **ENTER**.
3. To stop Follow Track navigation, press **NAV**, highlight **Stop Navigation**, and press **ENTER**.

Creating and Using Routes

You can create and store up to 50 user-defined reversible routes (numbered 1-50), with up to 300 points each.

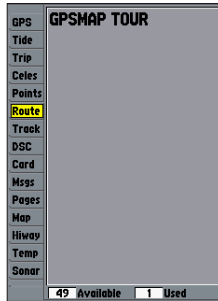

Route Tab

To navigate a QUICK NAV route:

1. Press **NAV/MOB**, and highlight **Follow Route**.
2. Press **ENTER**, and highlight **Create QUICK NAV Route**.
3. Use the map pointer to select a waypoint or map item, and press **ENTER**.

4. To add a new waypoint to the route, use the map pointer to select a map location, and press **ENTER**.

As you add each new waypoint to the route, the data window at the top of the Map Page shows the waypoint/map item name, bearing and distance from your location, and coordinates of the map pointer. The bottom of the screen shows the number of available points. A route line appears on the map to indicate each completed leg, and a dotted line appears indicating the distance and bearing to the map pointer from the last route waypoint.

5. Repeat steps 3 and 4 until you have finished defining all route waypoints.
6. Press **QUIT** twice to start your QUICK NAV Route.

To create a new route using the map window:

1. Press and hold **ADJ/MENU** to show the Main Menu.
2. Use the **ROCKER** to highlight the **Route** tab, and press **ADJ/MENU** to show the Route Options Page.
3. Select **New Route**, and press **ENTER**.
4. Follow steps 3 and 4 in the Navigating a QUICK NAV Route instructions.
5. When finished, press **QUIT** twice to return to the Route List Page.



ADD appears below the map pointer as you insert points.

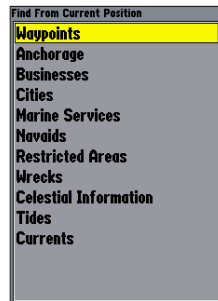

Choose the category from which you want to add a route point.

To create a route using the Route list:

1. Press and hold **ADJ/MENU** to show the Main Menu.
2. Use the **ROCKER** to highlight the **Route** tab, and press **ADJ/MENU** to show the Route Options menu.
3. Select **New Route**, and press **ENTER**.
4. Press **ADJ/MENU**, select **Use List**, and press **ENTER**.
5. Use the **ROCKER** to highlight the first available blank route slot, and press **ENTER**.
6. Select a category, press **ENTER**, and select the first point in your route.
7. Repeat steps 5 through 6 until your route is complete, and then press **QUIT**.

To navigate a saved route:

1. From any page, press **NAV**.
2. Use the **ROCKER** to highlight **Follow Route**, and press **ENTER**.
3. Highlight **Pick From Saved List**, and press **ENTER**.
4. Highlight the route you want to navigate, and press **ENTER**.

To stop navigation of a route:

Press **NAV**, highlight **Stop Navigation**, and press **ENTER**.

The following options are available on the Navigation menu by pressing **NAV** while navigating a route:

- **Invert Route**—reverses the route so you can follow it from the end point back to the beginning.
- **Re-Evaluate Route**—recalculates and reactivates the current route data. Selects the route leg closest to your current location as the active leg (the active leg defines the current from and to waypoints).

Find

The **FIND** key searches the unit for Waypoints, Cities, Tides, Anchorages, Businesses, Exits, Nav aids, Restricted Areas, and Wrecks Obstructions. If you press **FIND** while in Pan Mode, the unit centers its search from the location where the map pointer is located. Your location or the map pointer must be within a map outline area to search for BlueChart g2 information.

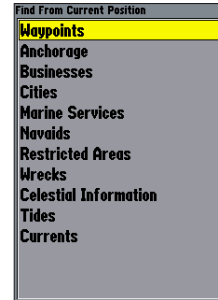

Find Items List

To Find an item from your current location:

1. From any page, press **FIND**.
2. Using the **ROCKER**, highlight a category from the list, and press **ENTER**.
3. For waypoints and cities, search using **By Name** or **Nearest**. Use the **ROCKER** to highlight a tab. For **By Name**, use the top field to spell out the name, or scroll down through the list. (See [page 8](#) for steps on entering a name.)

To Find an item from other locations:

1. From the Map Page, use the **ROCKER** to pan select a location, and press **FIND**.
2. Using the **ROCKER**, highlight a category from the list, and press **ENTER**.

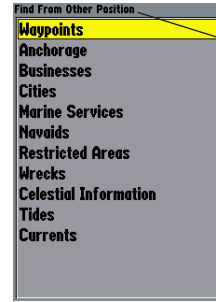

You can also Find items using the Map Pointer.

The Find option also supports a “find from” feature that centers your search around an item you have just found. For example, you search for “Restricted Areas” and you find a point named “Anchoring Prohibited.” If you press **FIND** again, “From Anchoring Prohibited” appears as the new find from point.

Additional Information

Each item on the map has information about the point available. The information varies depending on the type of data loaded on the optional data card. Sub tabs along the top of the detail window contain the information available for the item. Any additional options are shown along the bottom.

To view additional information for a Map item:

1. On the Map Page, use the **ROCKER** to highlight a map item, and press **ENTER**.
2. Use the **ROCKER** to highlight the individual tabs, and show the information. To scroll the text, highlight the field, and press **ENTER**. Use the **ROCKER** to scroll.

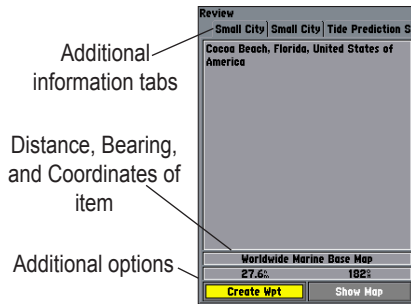

Information Window

DSC (Digital Selective Calling)

The DSC tab controls and sets up the DSC features on the GPSMAP 392/398/492/498.

DSC uses marine VHF radio and GPS technologies to transmit and receive location information. The chartplotter repeats the call properties received from the VHF radio on the chartplotter. The GPSMAP 392/398/492/498 requires input from a DSC-enabled VHF radio to show position, and sound/show alerts from a distress call or position report. Conversely, the VHF radio requires input from a GPS to transmit position coordinates for a distress call or position report. For connection information, refer to “Connecting the Power/Data Cable” on [page 92](#).

An emergency DSC distress call allows a vessel in trouble to transmit a substantial amount of information in a single transmission or call, without the need for voice communication. When any nearby rescuer receives the DSC signal, an alarm sounds and they immediately receive the location of the caller. The rescuer can choose to navigate to the caller’s location to assist, or forward the call on to the Coast Guard. When the Coast Guard receives the

call, they can immediately access the caller's information (such as who they are and the type of vessel) in their database while they are in transit to the caller's location.

A non-emergency DSC position report allows mariners to exchange and show the positions of one another. When a DSC position is received, the mariner can choose to create a waypoint or to show the received location on an electronic map.

Anytime a vessel receives a DSC call, they can store and quickly navigate to that location using a Go To. In order to use DSC, users must first register their VHF radio with the FCC and receive a Maritime Mobile Service Identity (MMSI) number. Garmin does not provide MMSI numbers.

For more information about Digital Selective Calling and Maritime Mobile Service Identity (MMSI) numbers, refer to [page 97](#) in the "Appendix."

Understanding Distress Calls

When the GPSMAP 392/398/492/498 receives a distress call from a connected DSC-enabled VHF radio, an alert message and notification page are shown, and an alarm tone is sounded. Distress Calls are shown in the DSC Call List and Log with a checkered symbol .

Understanding Position Reports

A position report is similar to a distress call except no alarm is sounded. Position reports are not broadcast to all DSC users and are shown with a boat symbol .

Review
DSC Waypoint
 000000001
Name

Position
N 28°46.534'
W080°38.878'
Reference
Current Position
0.0' 006'
Modified
10:39: 02-MAY-06
Create Wpt Show Map
Distress Call 

Review
DSC Waypoint
 000000001
Name

Position
N 28°46.534'
W080°38.878'
Reference
Current Position
0.0' 006'
Modified
10:42: 02-MAY-06
Create Wpt Show Map

Receiving DSC Calls

Each time you receive a distress call or position report, a Notification Page is shown, and the call is placed in the DSC Call List and Log. The Notification Page contains information about the call including: the type of call (distress or position report), the MMSI number of the caller, a user definable name, the time and date of the call, the bearing and distance from your current location, and the coordinates of the caller. To see the caller's location on a map, select the **Show Map** button. To create a waypoint at the caller's location, select the **Create Wpt** button. To close the Notification Page, press **QUIT**.

When a distress call or position report is placed in the Call List and Log, the information on the Notification Page is retained. To review a DSC call or log entry, highlight the entry and press **ENTER**. The DSC Entry Review Page is identical to the Notification Page with one exception, the entry can be deleted.

Review
DSC Waypoint
000000001
Name
Position
N 28°46.534'
W080°38.878'
Reference
Current Position
0.0'
006'
Modified
10:42'
02-MAY-06
Create Wpt
Show Map

DSC Entry Review Page

To review a call or log entry:

1. Press and hold **ADJ/MENU** to open the Main Menu.
2. Open the **Call List** or **Log** from the **DSC** tab.
3. Press up or down on **ROCKER** to highlight the call you want to review.
4. Press **ENTER** to open the DSC Entry Review Page.

DSC Call List

The DSC Call List shows the 50 most recent calls, even if the unit is left unattended. The Call List shows the most recent call from a vessel. If a second call from the same vessel is received, it replaces the first call in the Call List. Press **MENU** to sort the list and delete entries.

DSC Log

When DSC calls are received, they are automatically placed in the Log, with the most recent call at the top. The unit can log up to 100 calls. When 100 calls are logged, the oldest log is removed when a new call is received. Press **MENU** to sort the list and delete entries.

DSC Directory

The DSC Directory acts much like a phone book and can hold up to 50 entries. Pressing **MENU** from this page shows options to add a **New Item**, **Delete** a highlighted entry, or **Delete All** entries.

To add a new Directory entry:

1. Open the **DSC Directory** in the Main Menu.
2. Use the **ROCKER** to highlight the first blank space in the directory list, and press **ENTER**.
OR
Press **MENU**, highlight **New Item**, and press **ENTER**.

3. Enter the MMSI number, a name, and any comments.
4. When finished, highlight **OK**, and press **ENTER**.

The screenshot shows a 'Directory Item Review' form. At the top, there are tabs for 'Call List', 'Log', 'Directory', and 'Setup'. The form contains the following fields: 'Name' (ALEXANDER), 'MMSI' (00000001), 'Route' (010101010), 'Name' (SIMONE), 'DSC' (SIMONE), and 'Comment'. At the bottom, there are 'Delete' and 'OK' buttons. A status bar at the very bottom indicates '99 Available' and '1 Used'.

New Directory Item Page

When a distress call, position report, or directory item is named, the name is attached to that particular MMSI number. If a name is used, all DSC entries of the same MMSI number show the name.

Navigating to a Position Report or Distress Call

After a position report or a distress call is received, navigation can be quickly set to the call location.

The screenshot shows the 'DSC Waypoint' screen. It displays 'DSC Waypoint' with a selected item '000000001' and 'Name' 'ALEXANDER'. A 'Navigation' menu is open, showing options: 'Go To DSC', 'Go To Point', 'Follow Route', 'Follow Track', and 'TrackBack'. Below the menu, there are fields for 'Reference' (0.0), 'Current' (0.0), and 'Modified' (10:39:02 MAY-06). At the bottom, there are buttons for 'Next', 'Show Map', 'Create Wpt', and 'Delete'.

Navigating to a DSC Call

To navigate to a position report or distress call using the Nav key:

1. Press **NAV**.
2. With **Go To MMSI/Name** highlighted, press **ENTER**.

To navigate to a position report or distress call using the DSC alert page:

1. Highlight the call on the **Call List** or **Log**, and press **NAV**.
2. With **Go To MMSI/Name** or **DSC** highlighted, press **ENTER**.

Setting up DSC

The DSC Setup tab turns DSC chartplotter information screen **On** and **Off**. This also allows you to simulate distress calls and position reports while the unit is in Simulator Mode (see [page 3](#)). Simulating calls is helpful for practice before connecting to the real system. The distress call simulator also helps to check if alarms are working properly.

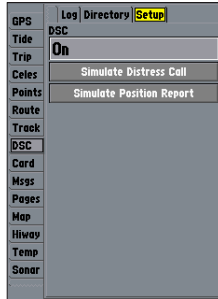

DSC Setup

AIS

AIS (Automatic Identification System) provides area traffic situational awareness. AIS provides ship IDs, position, course, and speed for ships equipped with a transponder within range.



NOTE: You must set your chartplotter communication to NMEA In / NMEA Out with a baud rate of 38400 to receive AIS information. Refer to [page 69](#) for information on changing communication settings.

AIS Setup options

AIS contains two setup options in the main menu.

- **AIS Vessels**—Auto, All Ranges, 30ft-800mi: sets the maximum zoom scale at which AIS vessels appear.
- **Heading Line**—Off, Time: draws an extension from the end of the boat icon in the direction of travel. For Time, enter the numeric time value you want the line to extend. The Time line length automatically adjusts as your speed changes.

MAIN PAGES

There are four main pages that are always available: Map, Compass, 3D Highway, and Active Route. Pressing **PAGE** opens a Pages window. You can use the **ROCKER** or press **PAGE** repeatedly to cycle through the pages. Three more pages, Map Split, Sonar, and Flasher, are available when the GPSMAP 392/398/492/498 Sounder receives sonar input. For information on the Sonar, Flasher, and Map Split Pages, refer to the “Using Sonar” section on [page 72](#).

With the Map Page shown, press **PAGE** several times. Each time you press **PAGE** the next main page appears. Each main page has an Adjustment Menu, which contains the setup options and functions that apply to that page. Press **ADJ/MENU** to show the Option Menu. Use the **ROCKER** to select an item from the adjustment menu, and press **ENTER**.

Notice that either **PAGE** or **QUIT** stops the current function and returns you to the main page. If you find yourself lost in a menu or you start a function you do not want, press **PAGE** or **QUIT**.

You can customize the main pages using the **DATA/CNFG** key. Press **DATA/CNFG** to remove the status bar and data fields from the top of any main page. Press and hold **DATA/CNFG** to customize the Main Pages.

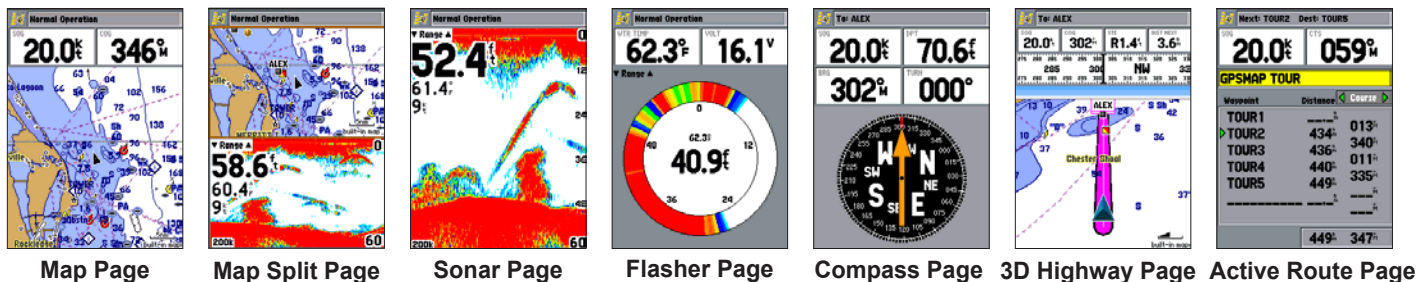

Map Page

The Map Page provides a comprehensive display of electronic cartography, plotting, and navigational data. When using the unit with optional BlueChart or MapSource data, the Map Page shows your boat on a digital chart, complete with geographic names, map items, nav aids, and a host of other chart features. It also plots your track and shows any routes and waypoints you create. The map pointer allows you pan and scroll to other map areas, determine the distance and bearing to a location, and perform various route and waypoint functions.

When the map pointer is active, an additional data window appears at the top of the map to indicate the location, range, and bearing to the map pointer, a selected waypoint, or map item. The map zoom range shown at the lower-right corner of the Map.

The Zoom **RANGE Down** and **RANGE Up** keys combined with the **ROCKER**, allow you select zoom ranges and move the map pointer. Two basic map operating modes, Position Mode and Pan Mode, determine what cartography is shown on the Map Page. Position Mode moves the cartography to keep the present position marker within the screen area. Pan Mode moves the cartography to keep the map pointer within the screen area.

The GPSMAP 392/398/492/498 starts in Position Mode, with your location centered on the Map Page. When sufficient map coverage is not available to keep your location centered, the position triangle moves toward the edge of the screen.

Pan Mode starts when the **ROCKER** is pressed. The map pointer is moved over the Map Page using the **ROCKER**. When the map pointer reaches the edge of the screen, the map scrolls forward under the map pointer.

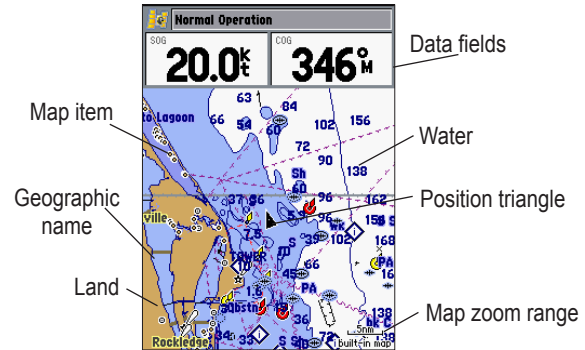

**Map Page shown Using
Built-In Cartography Data**

Using the Map Pointer

The map pointer pans away from your present location (even outside of your current detail coverage.) As you pan past the edge of the current Map Page, the screen actively scrolls forward to provide continuous map coverage. An hourglass symbol appears by the map pointer while the unit is busy drawing new map details.

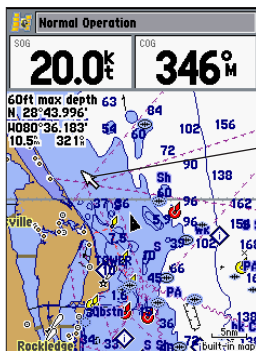

Move the map pointer over an item on the map to highlight it.

As you move the map pointer, the distance and bearing from your present location to the map pointer is shown in the data window, along with the map pointer's location coordinates. Keep in mind that when the map pointer is stationary, the distance and bearing from your present position changes as your location moves. The map pointer can also be used to view on-screen waypoint and map item properties directly from the Map Page.

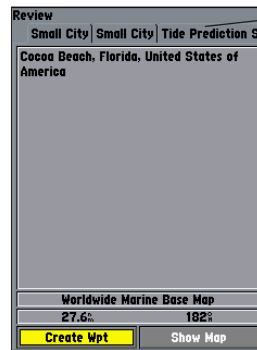

Additional information tabs

Pressing **ENTER** while highlighting a map item brings up additional details and options.

Additional options

To select an on-screen waypoint or map item with the map pointer:

1. Use the **ROCKER** to move the map pointer to a waypoint or map item. (If there are several waypoints grouped closely together, zoom in closer for a better view.) When a waypoint or map item is selected, it is highlighted on-screen, with the name and location shown.
2. Press **ENTER** to show details of the map item. When using BlueChart g2 or MapSource data, additional information tabs appear. Use the **ROCKER** to highlight the individual tabs, and show information and options.
3. Press **QUIT** to exit the review page.

Use the map pointer to create new waypoints directly from the map.

To create a waypoint with the map pointer:

1. Use the **ROCKER** to move the map pointer to the map location.
2. Press **ENTER**, and the New Map Waypoint window appears. (Do not hold down **ENTER**. Pressing and holding **ENTER** will mark a waypoint at your present position not at the map pointer's location.) If the map pointer is on a map item, press **ENTER**, and a new window with details about the item appears.
3. Press **ENTER** again on the highlighted **Create Wpt** option.
4. Press **ENTER** to confirm the new waypoint using the default four-digit name and symbol.

For more information about waypoints, see [page 8](#).

Selecting Map Zoom Ranges

The Map Page has 28 available range scales from 20 ft to 800 mi (5 m to 1,200 km.) The map zoom range is controlled by the **RANGE Down** and **RANGE Up** keys, with the current zoom range shown at the lower-right corner of the data window.

To select a map zoom range:

Press the **RANGE Up** key to zoom out and the **RANGE Down** key to zoom in.



NOTE: The zoom range value represents the distance from one end of the zoom range bar to the other.

5nm
built-in map

Using Built-In Basemap

3m
map card

Using BlueChart g2 or MapSource Data

2m
overzoom

Overzoom, no additional data is available

Cartography

The GPSMAP 392/398 system contains a preloaded U.S. inland freshwater cartography to its enhanced worldwide basemap information. The preloaded inland maps offer 50-meter shoreline resolution throughout the U.S., with even more detailed 10-meter resolution on select lakes. Other details include depth contours, tide and current data, boat ramps, mile markers, hazards, marinas, campgrounds, area roads, and more.

The GPSMAP 492/498 system contains preloaded marine map detail utilizing BlueChart® g2 technology. Coverage is for U.S. coastal areas, including Alaska and Hawaii. Features include integrated mapping, 2D or mariner's eye perspective, tide and current data, improved IALA symbols, nav aids, marinas, boat ramps, roads, and more.

Both units accept preprogrammed data cards and are compatible with the latest BlueChart® g2 series marine cartography. The unit shows cartography as long as there is chart information available for the range you have selected.

To change data field contents and configuration:

1. Press and hold **DATA/CNFG**. The Configuration window appears.
2. Using the **ROCKER**, highlight the function you want to add or remove, such as the status bar or first and second rows of data fields, and press **ENTER**. Only functions with a check mark in the check box to the left of the name appear on the main page.
3. Move the field highlight to the data field slider and use the **ROCKER** to select the number of data fields.
4. Move the field highlight to a data field, and press **ENTER**.
5. Using the **ROCKER** to move up or down on the list of data field options. Press **ENTER** to select an option.
6. To exit, press **QUIT**.

Map Page Options

Many features of the GPSMAP 392/398/492/498 are menu driven. Each main page has an options menu, allowing you to customize the corresponding page to your preferences and select special features that specifically relate to that page.

The Map Page provides access to functions and features relating to the Map Page.

To show and select the Map Page options:

1. Press **ADJ/MENU**.
2. Use the **ROCKER** to highlight an option, and press **ENTER**.

The available options are **Measure Distance**, **Show/Hide Detail**, and **Setup**.

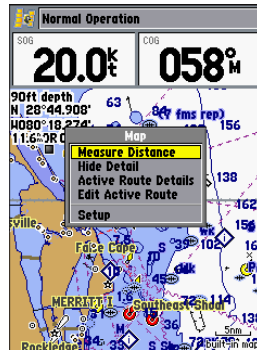

NOTE: Map Pointer, Highway, Location, and Sonar field options are only available on medium and large sized data fields.

Measure Distance—measures the bearing and distance between any two points on the Map Page.

Hide/Show Detail—hides and shows map details.

To measure the bearing/distance between two points:

1. Highlight **Measure Distance**, and press **ENTER**. An on-screen map pointer labeled **ENT REF** appears on the Map Page at your present location.
2. Move the map pointer to a reference point (the point that you want to measure from), and press **ENTER**.
3. Move the map pointer to the end measurement point. The bearing and distance from the reference point and map pointer coordinates is shown in the data window at the top of the screen. Press **QUIT** to finish.

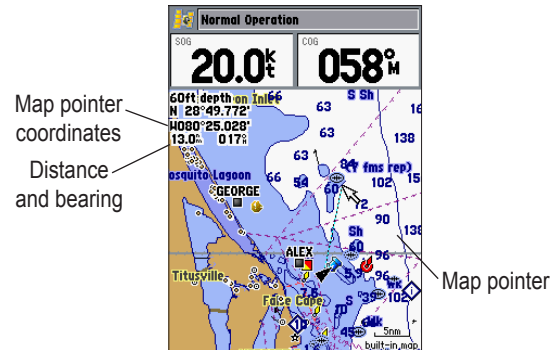

Setup—configures the Map Page preferences, including map detail, map orientation, automatic zoom, and various map items and points. Refer to “Main Menu—Map Tab” on [page 61](#) for more information.

To change a map setup feature:

1. From the Map Page menu, highlight **Setup**, and press **ENTER**.
2. Press left or right on the **ROCKER** to highlight a tab. Press up or down on the **ROCKER** to highlight the setting you want to change, and press **ENTER**.
3. Press up or down on the **ROCKER** to highlight to a setting, and press **ENTER**. To exit, press **QUIT**.

From the map setup page, you can access the following menu options by pressing **ADJ/MENU**:

- **All Map Defaults**—restores settings back to factory settings for all tabs.

Compass Page

The Compass Page provides graphic steering guidance to a destination waypoint, with an emphasis on the bearing to your destination and current direction of travel. The middle of the page features a rotating compass ring that shows your course over ground (track) while you are moving, and a bearing pointer that indicates the direction of the destination (bearing) relative to the course over ground. The compass ring and map pointer work independently to show—at a glance—the direction of your movement and the direction to your destination. For instance, if the arrow points up, you are going directly to the waypoint. If the arrow points any direction other than up, turn toward the arrow until it points up, and then continue in that direction.

This page provides better steering guidance when traveling at slower speeds and when making frequent directional changes. When you are not navigating to a waypoint, the compass ring shows the current direction of travel but the arrow does not appear.



NOTE: The bearing pointer, bearing bug, and compass ring can point in various directions when you are stationary or at very low speeds. When you start moving, the map pointer is correct.

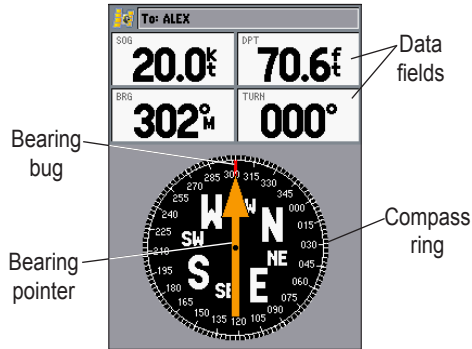

The data window, located at the top of the page, provides a user-selectable layout of various types of useful data. Each data field can be configured to show several data options. The data window layout can be configured to show additional data fields and change the size of the data shown. The round compass becomes a tape compass when the data configuration limits space. Refer to [page 30](#) for data field configuration instructions.

3D Highway Page

The 3D Highway Page provides mariner's eye perspective for guidance to a destination waypoint, placing greater emphasis on the straight-line course, and the distance and direction you are off course. As you head toward your destination, the middle of the screen provides visual guidance to your waypoint on a moving graphic highway. Your present location is at the bottom center of the 3D Highway Page. Mariner's eye perspective provides situational awareness while navigating. The line down the middle of the highway represents your course. As you navigate toward a waypoint, the highway moves—indicating the direction you are off course. To stay on course, steer toward the center of the highway.

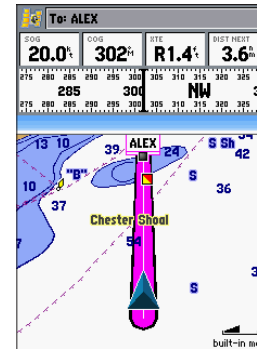

The four data fields at the top of the page provide additional user-selectable guidance information. A compass ribbon shows your current heading along with a dark, vertical bar that indicates the direct bearing to the navigation point. When the dark vertical indicator (or arrow) lines up with the lighter red bar in the middle, you are heading directly to the navigation point. Use the 3D Highway Page as your primary navigation page in lieu of the Compass Page when your main concern is following a defined course.

Each data field at the top of the page can be configured to show several data options. The data window layout can be configured to show additional data fields and change the size of the data shown. Refer to [page 30](#) for more information.

To zoom in or out on the 3D Highway Page:

Press either the **RANGE Down** or **RANGE Up** key to increase or decrease the zoom range.

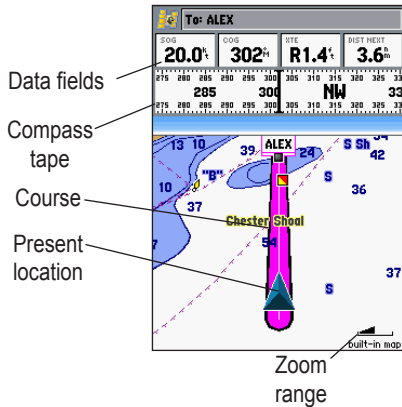

3D Highway Page Options

The 3D Highway options page selects the waypoints and tracks shown and shows/hides cartography.

To show and select the 3D Highway Page options:

1. Press **ADJ/MENU**. Select the **Hiway** tab.
2. Using the **ROCKER**, highlight an option, and press **ENTER**.

Check or uncheck the options you want to show or hide on the 3D Highway Page.

Preview window

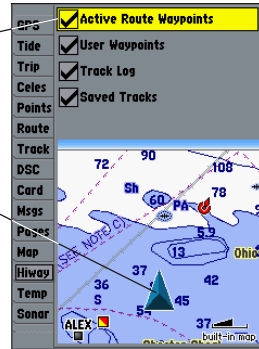

3D Highway Page Setup

The following options are available from the 3D Highway Page menu:

- **Hide/Show Cartography**—toggles between hiding and showing map details. This option is only available when an optional cartography data card is inserted in the unit.
- **Setup**—selects what waypoints and tracks are shown on the 3D Highway Page. Use the **ROCKER** and **ENTER** keys to select or deselect the options.

Active Route Page

The Active Route Page shows each point of the active route, with the point name, distance and choice of Course, ETA, Fuel, Leg Distance, Leg Fuel, Leg Time, Sunrise, Sunset, or Time To for each point from your present location. The current destination point is marked with an arrow icon. As you navigate a route, the waypoint list automatically updates to indicate the next active point first. The Active Route and Route Review Pages share many of the same features and options. For more information on the Active Route Page, see [page 17](#).

Active Route Page Options

The Active Route Page Options function the same as the Map Page Options. Refer to [pages 17-19](#) for information on the Use Map, Add Before, and Remove options.

Next: TOUR2 Dest: TOUR5		
SOG	20.0k	CTS
		059M
GPSMAP TOUR		
Waypoint	Distance	Course
TOUR1	---	---
▶ TOUR2	434 ^m	013 ^h
TOUR3	436 ^m	340 ^h
TOUR4	440 ^m	011 ^h
TOUR5	449 ^m	335 ^h
---	---	---
	449 ^m	347 ^h

Active Route Page

MAIN MENU

The Main Menu provides access to various waypoint, system, navigation, interface management, and setup menus. The 19 Menu tabs are divided into categories by function. The Main Menu is available from any page in the system, and is accessed by pressing and holding **ADJ/MENU**. See [page 6](#) for additional instructions on changing settings and entering data.

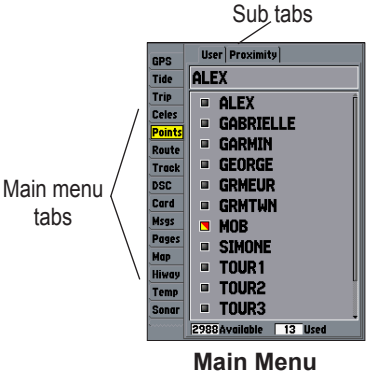

To select a Menu tab from the Main Menu:

1. Press up or down on the **ROCKER** to highlight a tab. The information for the highlighted tab automatically appears to the right. If you want to select any of the sub tab items, press right on the **ROCKER**, then press up or down to select individual items.
2. Either press **ADJ/MENU** for additional submenu options, or press **ENTER** to make changes to the highlighted item. Press left on the **ROCKER** to get back to the Main Menu.
3. Press **QUIT** to exit the Main Menu.

GPS Tab

The GPS tab provides a visual reference of satellite acquisition, receiver status, and accuracy. The status information provides an idea of what the receiver is doing at any given moment. The sky view and signal strength bars give you an indication of what satellites are visible to the receiver and whether or not they are being tracked. The signal strength is shown on a bar graph for each satellite, with the satellite number below. As the receiver locks onto satellites, a signal strength bar appears for each satellite in view.

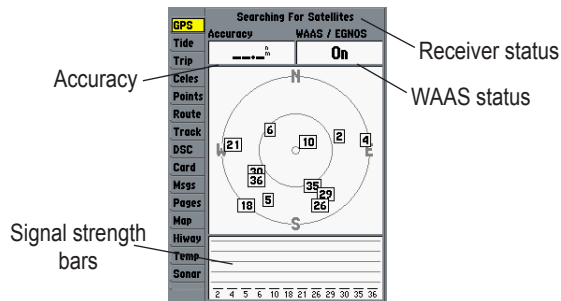

The status field indicates “Ready for Navigation” when the GPSMAP 392/398/492/498 has collected the necessary data from satellites to calculate a fix. The unit then updates the location, date, and time.

You can use the sky view to help determine if any satellites are being blocked, and whether you have a current location fix. The sky view shows a bird’s-eye view of the position of each satellite relative to the receiver’s last known location.

The outer circle represents the horizon (north up), the inner circle 45° above the horizon, and the center point a position directly overhead. You can also set the sky view to a Track up configuration, causing the top of the sky view to align along your current track heading.

- **Searching for Satellites**—the receiver is looking for and collecting data from satellites visible at its last known or initialized position, but has not collected enough data to calculate a fix.
- **Ready for Navigation**—at least three satellites have been acquired and your location is now being calculated in latitude, longitude, and elevation.
- **Ready for Nav with WAAS**—at least three satellites and a WAAS/EGNOS satellite have been acquired and your location is now being calculated in latitude, longitude, and elevation.
- **Simulating**—the receiver is in Simulator Mode.

GPS Tab Options

The GPS tab features an options page that provides access to functions and features relating to the GPS Info Page.

To show and select the GPS Tab options:

1. Press **ADJ/MENU** to open the Main Menu.
2. Using the **ROCKER**, highlight an option, and press **ENTER**.

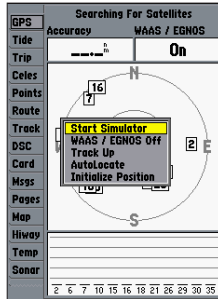

GPS Tab Options

To Disable/Enable WAAS capability:

1. From the **GPS** tab, press **ADJ/MENU**.
2. Use the **ROCKER** to highlight **WAAS Off** or **WAAS On**, and press **ENTER**.

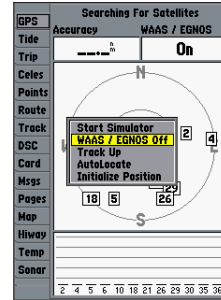

Highlight **WAAS Off**, and press **ENTER** to disable the WAAS capabilities.

Tide Tab

Use the Tide tab to view tide and current information. The Tide tab contains two sub tabs: Tide and Current.

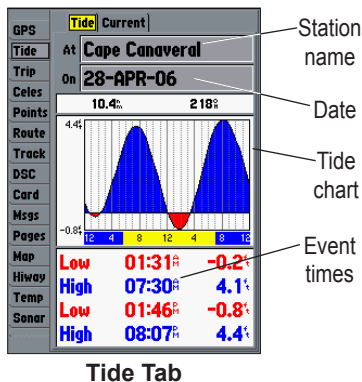

Tide Sub Tab

The Tide sub tab contains a graphical chart that shows Tide Station information in a 24-hour span starting at midnight. You can choose from different dates and more than 3,000 Tide Stations around the U.S.A. coastline, Alaska, Hawaii, western Canada, and several of the Caribbean islands. The top of the Tide sub tab shows the Tide Station, the date, and the distance and bearing to the Tide Station from your location.

The bottom of the Tide chart shows a 24-hour block of local time for your location. Daytime (yellow bar) and nighttime (blue bar) at the Tide Station are shown across the time scale, with the time progressing from left to right (sunrise and sunset information might not be available for some Tide Stations). The solid, light vertical lines are in 4-hour increments, and the light, dotted vertical lines are in 1-hour increments. A solid, vertical line (with the local time at the top) indicates the tide height corresponding to the time shown in the local time box.

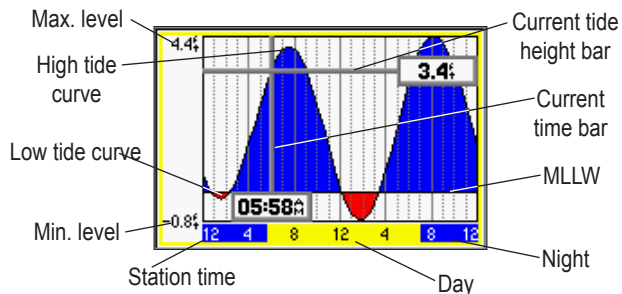

The Tide curve is shown as a shaded area, where higher tides are taller (blue) and lower tides are shorter (red). The solid, horizontal line indicates the tide height. The figure to the left of the line shows the present tide level. The Mean Lower Low Water (MLLW) appears as a solid, horizontal line near the bottom of the chart (this line appears only if the tide height range is zero or below).

The numbers on the top and bottom of the left side indicate the maximum and minimum levels. The four data fields below the chart indicate event times and levels at which the tide changes starting in the upper-left field, going downward, then to the upper-right, and down again. When comparing with other tide tables, verify the depth unit value is the same for both sources. The bottom of the chart shows the amount of time (in hours and minutes) until the next low tide and high tide.

To select the Tide Station nearest to your location:

1. Highlight the **At** field, and press **ENTER** to open the Find Tides Page.
2. Highlight **Current Position**, and press **ENTER** to open the Find Near Current Position Page.
3. Select a **Tide Station** from the list, and press **ENTER**. As you move the highlight over each Tide Station in the list, the station is highlighted on the Map window. The distance and bearing from your location to the highlighted Tide Station are shown at the bottom of the list.

If you are not within this range, the message “None Found” appears. Use the Map Position option to select a location closer to a Tide Station.

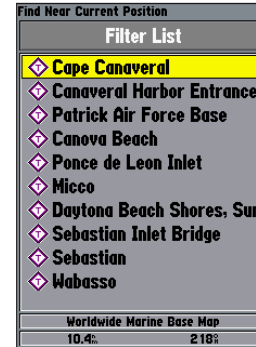

Select from a list of Tide Stations.

To select a Tide Station from a map location:

1. Highlight the **At** field, and press **ENTER** to open the Find Tides Page.
2. Highlight **Map Position**, and press **ENTER** to open the Find Near Current Position Page.
3. Press up or down on the **ROCKER** to move the map pointer to a map location, and press **ENTER**. The Find Near Other Position Page shows a list of Tide Stations near the selected map location.
4. Select a Tide Station, and press **ENTER**. If the “None Found” message appears, repeat steps 1-3 until you find a Tide Station.

Viewing Tide Information

You can change the date to see tide charts for other days, or move the time bar in approximately five-minute increments to show tide heights at various times.

To change the date of the tide chart:

1. Using the **ROCKER**, highlight the **On** field, and press **ENTER**.
2. Enter a date, and press **ENTER**. The tide chart is updated to show tide information for the selected date.

To view tide heights at various times on the tide chart:

1. Highlight the tide chart.
2. Press left or right on the **ROCKER** to change the time and day. The day changes as you move past the edge of the tide chart.

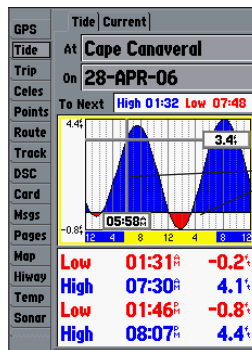

Move the **ROCKER** to see tide heights at different times. Tide data shows in a black box when in map pointer mode.

Current Sub Tab

The Current sub tab contains graphical charts showing information for currents in a 24-hour span starting at midnight. You can choose from different dates and Current Stations around the U.S.A. coastline, Alaska, Hawaii, western Canada, and several of the Caribbean islands. The top of the Current sub tab shows the current station, and the date. The bottom of the tab shows the distance and bearing from your location.

The Current sub tab contains two charts—one for speed and one for direction.

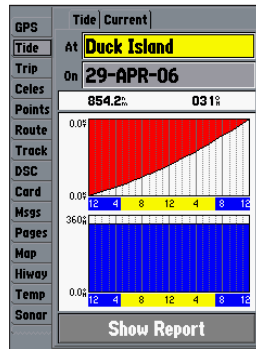

The top chart is the speed chart, which shows the speed of a given current at any point during the day. The shaded area is blue (Flood Current) when the current is heading toward shore; the shaded area is red (Ebb Current) when the current is heading away from shore.

The bottom chart is the direction chart, which shows the direction of the current at any given point during the day (based on the north reference, not true north.)

The bottom of each chart shows a 24-hour block of local time for your location. Day (yellow bar) and night (blue bar) at the Current Station appear across the time scale, with the time progressing from left to right (sunrise and sunset information may not be available for some stations). The solid, light vertical lines are in 4-hour increments, and the light, dotted vertical lines are in 1-hour increments. A solid, vertical line (with the local time at the top) indicates the strength of the current that corresponds to the time shown in the local time box.

To select the Current Station nearest to your location:

1. Highlight the **At** field, and press **ENTER** to open the Find Currents Page.
2. Highlight **Current Position**, and press **ENTER** to open the Find Near Current Position Page.

3. Select a Current Station from the list, and press **ENTER**. As you move the highlight over each Current Station in the list, the station is highlighted on the Map window. The distance and bearing from your location to the highlighted station are shown at the bottom of the list.

To select a Current Station from a map location:

1. Highlight the **At** field, and press **ENTER** to open the Find Currents Page.
2. Highlight **Map Position**, and press **ENTER** to open the Find Near Map Position Page.
3. Press up or down on the **ROCKER** to move the map pointer to a map location, and press **ENTER**. The Find Near Map Position Page shows a list of Current Stations near the selected map location.
4. Select a Current Station, and press **ENTER**. If the “None Found” message appears, repeat steps 1-3 until you find a station.

Viewing a Current Report

Press the Show Report soft key to view a detailed report of all times and values for all the minimum and maximum current flows through the day including Flood, Slack, and Max Ebb times and strengths.

Trip Tab

The Trip tab shows the Trip Odometer, Moving Average speed, Total Average speed, Maximum Speed, Stopped Time, Moving Time, Total Time, and Odometer. To reset the data, choose from Reset Trip, Reset Max Speed, Reset Odometer, or Reset All, and press **ENTER**.

	Trip Odometer	Stopped Time
GPS	12.8%	12:27:20
Tide		
Trip	Moving Average	Moving Time
Celes	0.3%	02:25:27
Points	Total Average	Total Time
Route	0.0%	--:--:--
Track	Maximum Speed	Odometer
DSC	18.6%	0.8%
Card	Reset Trip	
Msgs	Reset Max Speed	
Pages	Reset Odometer	
Map	Reset All	
Hiway		
Temp		
Sonar		

Celes (Celestial) Tab

The Celestial tab shows celestial data for sun and moon rise and set, moon phase, and the approximate sky view location of the sun and moon. The moon phase shows the current visible portion of the moon as a light color. You can show this data for your present location, a location from the map, or a Find item location. You can use today's data, or select a different date and time.

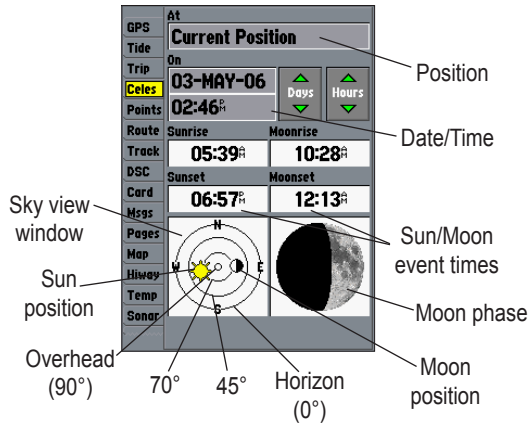

To choose a different location:

1. From the **Celes** tab, highlight the **At** field, and press **ENTER**.
2. From the Find list, highlight any category, and press **ENTER**. If you want to reference a Find item, select from the Find list, and press **ENTER**.
3. Select an item from the list or tab lists, and press **ENTER**. For a location from the map, choose **Map Position**, press **ENTER**, select a location on the map, and press **ENTER**.
4. From the Find item detail page, highlight **OK**, and press **ENTER**.

The location the unit is using appears in the Date/Time/Position field. The time tables shown are based on your current time zone. When using a position from another location outside of your time zone, you need to set the time zone for that location. See [page 68](#) for more information on setting time zones.

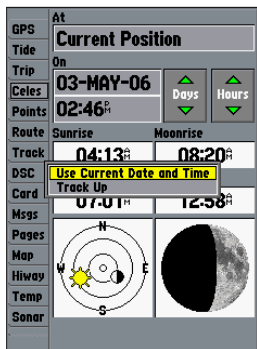

Celestial Tab Menu

To change the time or date:

1. On the **Celestial** tab, use the **ROCKER** to highlight the **Days** or **Hours** button, and press **ENTER**. Press up or down on the **ROCKER** to change the days or hours. Press **QUIT** to exit.

OR

Highlight the **On** field, and press **ENTER**.

2. Enter a new date or time, and press **ENTER**.

To use the current date and time:

From the **Celes** tab, press **ADJ/MENU**, use the **ROCKER** to highlight **Use Current Date and Time**, and press **ENTER**.

Points Tab

The Points tab contains two waypoint sub tabs, User and Proximity, which allows you to manage a large number of waypoints quickly and efficiently. The sub tabs also provide continuously updated proximity waypoint alarms that can be used to define items, such as submerged hazards or shallow waters.



Points Tab

To select the Points sub tab:

1. Use the **ROCKER** to highlight the **Points** tab. A list of stored waypoints appear to the right of the Main Menu list.
2. Press right one time on the **ROCKER**. The **User** tab is now highlighted.
3. Press down on the **ROCKER** until a waypoint is highlighted.

User Waypoint List

The User list on the points tab shows a master list of all waypoints currently stored in memory. From the User list, you can review, edit, rename or delete individual waypoints, or delete all user waypoints. The total number of stored and available waypoints is shown at the bottom of the User page, with the stored waypoints arranged in alphanumerical order.

The following options are available:

- **New Waypoint**—allows you to create a waypoint. (See [page 8](#) for creating a waypoint)
- **Delete**—deletes selected waypoint from and waypoint list and route.
- **Delete By Symbol**—deletes waypoints that use the same symbol.
- **Delete All**—deletes all waypoints from the unit.



NOTE: When a waypoint is deleted from the list, it cannot be recovered from the unit. It is advisable to back up important waypoints to a computer using an optional PC cable and interface software or record them manually.

To show the waypoint menu options:

Using the **ROCKER**, highlight the **User** tab, and press **ADJ/MENU**.

To scroll through and review the waypoint list:

1. With the **ROCKER**, highlight the **Points** tab, and then highlight the **User** sub tab.
2. Use the **ROCKER** to scroll through the list.
3. Press **ENTER** to review the highlighted waypoint on the Waypoint Edit Page.
4. Press **ENTER** to return to the list and automatically highlight the next waypoint.

To search for a waypoint by name:

1. Highlight the name field, and press **ENTER**.
2. Use the **ROCKER** to select the first letter of the name.
3. Press right on the **ROCKER**, and enter the second letter, if you do not see the name in the list below.
4. Repeat steps 2 and 3 until the name appears. Press **ENTER** when you see the name.
5. Highlight the name on the list, and press **ENTER** again to review the waypoint. When finished, highlight **OK**, and press **ENTER**.

To delete an individual waypoint from the list:

1. Use the **ROCKER** to highlight the waypoint to delete, and press **ADJ/MENU**.
2. Highlight **Delete**, and press **ENTER**. You can also highlight the waypoint, press **ENTER**, then highlight **Delete**, and press **ENTER**.
3. Press **ENTER** to delete the selected waypoint.

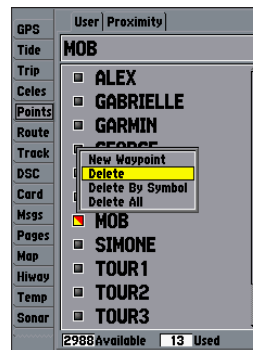

To delete waypoints by symbol:

1. From the **User** sub tab, press **ADJ/MENU**. Select **Delete By Symbol**, and press **ENTER**.
2. Use the **ROCKER** to highlight the symbol of the waypoint(s) to delete, and press **ENTER**.
3. Press **ENTER** to delete the waypoint by symbol. Otherwise, choose **Cancel**, or press **QUIT**.

To delete all waypoints or the entire waypoint list:

1. Press **ADJ/MENU** to select the options window.
2. Use the **ROCKER** to highlight **Delete All**, and press **ENTER**.
3. Highlight **OK**, and press **ENTER** to delete all waypoints.

Proximity Waypoint List

Use the Proximity list to define an alarm circle around a stored waypoint. The alarm circle can help you avoid reefs, rocks, or restricted waters. You can add a maximum of 10 waypoints or on-screen map items to proximity alarms with a maximum alarm radius of 99.99 nautical or statute miles or kilometers.

If a proximity alarm circle overlaps with an existing alarm circle, a “Proximity Overlaps Another Proximity Waypoint” message appears. Because the unit only alerts for one of the overlap points, use caution when navigating in these areas. If your boat enters an alarm circle overlap, you are only alerted to the closest proximity waypoint.

GPS	User Proximity
Tide	Proximity Alarm
Trip	On
Celes	Waypoint Distance
Points	GABRIELLE 15.00 ⁿ
Route	
Track	
DSC	
Card	
Msgs	
Pages	
Map	
Hiway	
Temp	
Sonar	

To add a proximity waypoint:

1. On the **Points** tab, highlight the **Proximity** sub tab.
2. Press **ADJ/MENU**, and select **New Waypoint**. The **Find** screen appears. Highlight **Waypoints**, and press **ENTER**.
3. To select a waypoint from the list, use the **ROCKER** to highlight a waypoint from the **User** or **Nearest** tab.
4. Press **ENTER** to confirm. The **Distance** field is now highlighted.
5. Press **ENTER** and use the **ROCKER** to enter a proximity radius (to 99.99 units).
6. Press **ENTER**, when finished.

To turn proximity alarms on or off:

1. Use the **ROCKER** to highlight the field below **Proximity Alarm**, and press **ENTER**.
2. Select **ON** or **OFF**, and press **ENTER**.

To show the waypoint menu options:

Using the **ROCKER**, highlight the **Proximity** tab, and press **ADJ/MENU**.

To clear one or all proximity waypoints from the list:

1. Use the **ROCKER** to highlight the proximity waypoint, and press **ADJ/MENU**.
2. To clear a single alarm, highlight **Delete**, and press **ENTER**.
3. To clear all proximity waypoints, select **Delete All**, and press **ENTER**.
4. Use the **ROCKER** to highlight **OK**, and press **ENTER**.

The following options are available from the Proximity sub tab:

- **New Waypoint**—creates a waypoint and adds it to the proximity list.
- **Delete**—removes a selected waypoint from proximity list.
- **Delete All**—removes all waypoints from proximity list.

Route Tab

The Route tab shows all the routes currently stored in memory, along with a descriptive name for each route. After you create a route, you can start using it for navigation with the **NAV** key. You follow the route in the same sequence as it was originally created, or you can invert the route and navigate from the end waypoint back to the beginning waypoint. From the Route list menu, you can choose New Route (page 17), Copy, Delete, or Delete All.

If you highlight a route name from the Route List and press **NAV**, the name automatically appears.

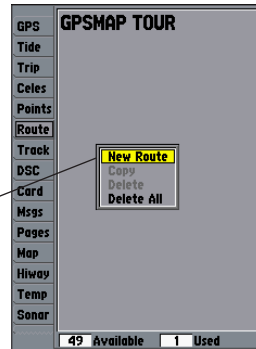

To copy or delete a route:

1. From the **Route List**, highlight the route you want to copy or delete using the **ROCKER**, and press **ADJ/MENU**.
2. Choose either **Copy** or **Delete**, and press **ENTER**. With **OK** highlighted, press **ENTER** again to confirm a deletion. The copied route uses the same route name with an additional number, starting at 1, at the end of the route name.

To delete all routes:

1. From the **Route List**, press **ADJ/MENU**.
2. Highlight **Delete All**, and press **ENTER**. With **OK** highlighted, press **ENTER** again to delete all routes.

Route Review Page

After you create a route, use the Route Review Page to review and modify the route shown.

To show the Route Review Page:

1. Press and hold **ADJ/MENU**, and then highlight the **Route** tab.
2. Highlight the route you want to review, and press **ENTER**.
You are now on the Route Edit Map Page.

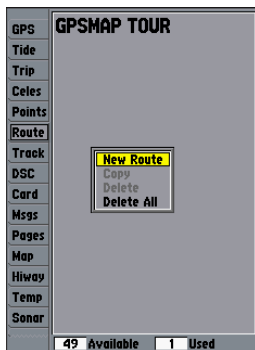

Route List Menu



The Route Review Page also allows you to enter your own 15-character name for any listed route. By default, the name includes the first and last waypoints in the route.

To enter a custom route name:

1. From the **Route Review** Page, highlight the route you want to change, and press **ENTER**.
2. Press **ADJ/MENU**, and use the **ROCKER** to select **Edit Route Name**. Press **ENTER**.
3. Use the **ROCKER** to enter a name, and press **ENTER** when finished.

On the Route Review Page, you can review the route points (waypoints or map items) one at a time from the list.

To review individual route points:

1. Highlight a route, and press **ENTER**.
2. Press **ADJ/MENU**, highlight **Use List**, and press **ENTER**.
3. Highlight the waypoint you want to review, and press **ENTER**. On the waypoint review window, you can choose **Delete**, **Next** (highlight the next point on the route list), **Show Map** (show the point on a map window), or **Move Wpt** (permanently delete the waypoint from the unit), and press **ENTER**.

When you return to the route point list, the next point in the route is automatically highlighted. Press **ENTER** repeatedly to review each point on the route.

Waypoint	Distance	Course
TOUR 1	0.0 ^m	004 [°]
TOUR 2	2.3 ^m	330 [°]
TOUR 3	4.8 ^m	002 [°]
TOUR 4		326 [°]
TOUR 5		
-----		---

Active Route
 Use Map
 Add Before
 Remove
 Plan

17.7^m 337^{ft}

Route Review Options Menu

Route Review Menu Options

Menu options available from the Route Review Page are Use Map, Add Before, Remove, and Plan.

Use Map—allows you to review and modify the route shown for each point (waypoint or map item) on a map page. Use the map pointer to insert a new route point on a route leg, or review the waypoint, or map item.

To add a point to an existing route:

1. From the Route Review Page, press **ADJ/MENU**, highlight **Use Map**, and press **ENTER**.
2. Use the **ROCKER** to move the map pointer labeled “ADD” to the next point in the you want in the route.
3. Press **ENTER**.



Highlight a point, and press **ENTER** to review it.

To edit a route point:

1. From the Route Review Page, press **ADJ/MENU**, highlight **Use Map**, and press **ENTER**.
2. Use the **ROCKER** to highlight a route waypoint, and press **ENTER**. Use the **ROCKER** to edit the waypoint properties. A menu of editing choices appear, with options for removing, moving (user waypoints only), or adding turns to the beginning or end of the route.

To remove a route waypoint:

1. From the Route Review Page, press **ADJ/MENU**, highlight **Use Map**, and press **ENTER**.
2. Use the map pointer to highlight the waypoint you want to remove, and press **ADJ/MENU**.
3. Highlight **Remove**, and press **ENTER**.

To move a route waypoint:

1. From the Route Review Page, press **ADJ/MENU**, highlight **Use Map**, and press **ENTER**.
2. Use the map pointer to highlight the waypoint to move, and press **ADJ/MENU**.
3. Highlight **Move**, and press **ENTER**.
4. Move the map pointer to the new map location, and press **ENTER**.

To add turns at the beginning or end of the route:

1. Select the first (to add waypoints to the beginning of the route) or last (to add waypoints to the end of the route) route waypoint with the map pointer, and press **ADJ/MENU**.
2. Highlight the **Add** option, and press **ENTER**.
3. Move the map pointer to the new point or location, and press **ENTER**.
4. Repeat step 3 to insert additional waypoints, or press **QUIT** to finish.

Route edit mode also allows you to insert a new route waypoint in any route leg using the map pointer.

To insert a new waypoint between two existing route waypoints:

1. Use the **ROCKER** to select the leg you want to insert the new waypoint in, and press **ENTER**.
2. Move the map pointer to the new map location, existing waypoint, or map item (**ADD** is shown below the arrow and the route lines move with the arrow), and press **ENTER**.

Add Before—inserts a waypoint into the list of route points or add a point(s) onto the end of the route.

To insert a point into the route, or add a point to the end of the route:

1. From either the Route Review or Active Route Pages, use the **ROCKER** to highlight the point you want to insert the new point before (to add a point to the end, highlight the blank field at the bottom of the list), and press **ADJ/MENU**.
2. Highlight **Add Before**, and press **ENTER**.
3. From the **Find** menu, highlight **Waypoints**, and press **ENTER**. (You can also choose from other points, such as Cities or Tide Stations from this list.) From either the **User** or **Nearest From Current Location** tab lists, choose the waypoint you want, and press **ENTER** twice. (See [page 48](#) for searching for waypoints by name.)

Drag the route leg to an existing waypoint (shown), map item, or a blank spot on the map to create a new route point.

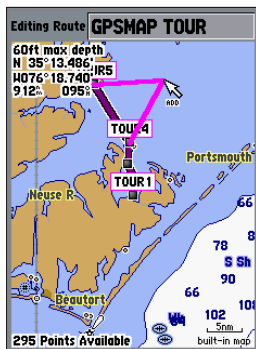

Remove—removes a point (waypoint or map item) from a route. This option is available from both the Route Review and Active Route Pages.

To remove a point from a route:

1. From either the Route Review or Active Route Pages, use the **ROCKER** to highlight the point to remove, and press **ADJ/MENU**.
2. Highlight **Remove**, and press **ENTER**.

Plan—the Route Review and Active Route Pages also show trip-planning information for each leg or the entire route. Available information includes Course, ETA, Fuel (to point), Leg Distance, Leg Fuel, Leg Time, Sunrise and Sunset (at point location), and Time To (point).

To plan your route:

1. From the Route Review Page, press **ADJ/MENU**, highlight **Plan**, and press **ENTER**.
2. Use the **ROCKER** to enter planning data in the Speed, Depart Time, Fuel Flow, and Depart Date fields.

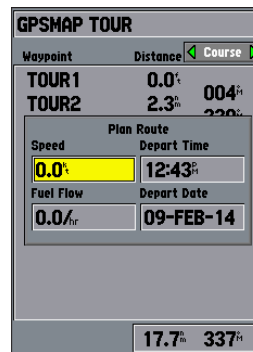

Trip Planning Data Fields



NOTE: Fuel flow rates on your unit are measured in units per hour. System setting changes for units of measure (statute, nautical, or metric) do not affect the fuel flow measure. You should enter fuel flow rates based on available information for your vehicle's (operator's manual performance specifications) and note of the units of measure (gallons, liters.)

Track Tab

Use the Track tab to specify whether or not to record a track log, define how it is recorded, or save track log data for future use. The Track Logs Page also provides an indicator of the memory used for the active track log and allows you to clear the track memory. See [page 14](#) for TracBack information. The Track tab is divided in two sub tabs: Active and Saved.

Active Sub Tab

The Active sub tab is for the active log (the log currently being recorded). It shows track memory used and current settings. Refer to [page 58](#).

Saved Sub Tab

The Saved sub tab shows and manages a list of all saved track logs, allows for TracBack activation, and Map Page of saved logs. The active log stores up to approximately 10,000 track log points, based on the criteria specified in the Track settings. You can save up to 15 track logs in memory, with up to 750 track log points in each saved log. A TracBack can be started from any of the saved tracks on this tab.

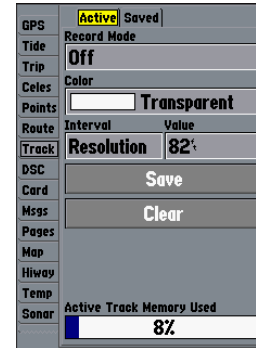

Active Track Tab

For the Active tab, the following settings are available:

- **Record Mode**—contains three track recording options:
 - **Off**—no track log is recorded. If you select Off, you cannot use the TracBack feature.
 - **Fill**—a track log is recorded until the track memory is full.
 - **Wrap**—a track log is continuously recorded, wrapping through the available memory (replacing the oldest track data with new data).
- **Interval**—defines the frequency at which the track plots are recorded. Three interval settings are available:
 - **Distance**—records track based on a user-defined distance between points.
 - **Time**—records track plot based on a user-defined time interval.
 - **Resolution**—records track plot based on a user-defined variance from your course over ground. The resolution option is the default setting and is recommended for the most efficient use of memory and TracBack performance. The distance value (entered in the value field) is the maximum error allowed from the true course before recording a track point.

- **Value**—defines the distance or time used to record the track log.
- **Save**—saves the current active track log.
- **Clear**—erases the active track log stored in memory.

For the Saved tab, the following menu options are available:

- **Delete Track**—deletes highlighted saved track log from memory.
- **Delete All**—deletes all saved track logs from memory.

DSC Tab

DSC uses marine VHF radio and GPS technologies to transmit and receive location information. DSC is used by mariners for two major operation: distress calls and position reporting.

See [page 21](#) and the “Appendix” for more information on DSC and using it with your GPSMAP 392/398/492/498.

Card Tab

The Card tab contains options for saving waypoints, routes and tracks to a data card. When data is saved to a data card, it can be exchanged with other compatible units and Garmin’s MapSource software program on your PC.

To transfer data on your PC to or from a data card:

1. Insert the data card. From the **Card** tab, select the check box next to each type of item you want to transfer.
2. Highlight **Save To Card**, and press **ENTER** to save the selected items to the data card.
3. If transferring data from the card to the unit, highlight **Merge From Card**, and press **ENTER** to combine the selected items with existing GPS data. Highlight **Replace From Card**, and press **ENTER** to overwrite all selected items on your GPS.
4. A Transfer Complete message appears after the data is transferred. Press **QUIT**.

Msgs Tab

The Message tab on the Main Menu shows a list of messages generated by your GPSMAP 392/398/492/498. Use the **ROCKER** to scroll through the entire list of messages on the Log tab.

To view the messages:

1. Press and hold **ADJ/MENU** twice to open the Main Menu.
2. Highlight **Message** from the vertical list of tabs.

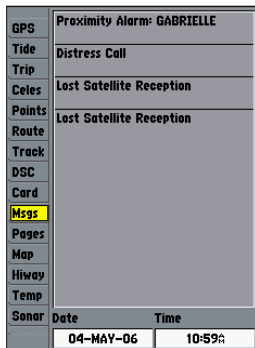

3. Use the **ROCKER** to highlight a message. Press **ENTER** to view detailed information about that message.

To delete all messages:

1. Press and hold **ADJ/MENU** twice to open the Main Menu.
2. Highlight **Message** from the vertical list of tabs.
3. Highlight a message, and press **ADJ/MENU**. **Delete All** appears.
4. Press **ENTER**. Select **OK**, and press **ENTER** again to confirm.

Pages Tab

The Pages tab allows you to turn main pages on or off and customize the order.

To turn a main page on or off:

1. Use the **ROCKER** to highlight the page name field. Press **ENTER** to show a list of pages available.
2. Select **None**. The page is now turned off.

To customize the main pages order:

1. Use the **ROCKER** to highlight a page name field.
2. Press **ENTER** to show the main page list for the numbered spot.
3. Highlight a page name, and press **ENTER**.

The **Reset Pages** button returns the unit to the default page sequence.

Map Tab

The Map tab changes the display properties of the Map Page. The following pages contain descriptions of the Map tab's six sub tabs.

Prefs Sub Tab

Prefs	Detail	Labels	Nav	AIS
Map Outlines	On			
Symbol Set	NOAA			
Light Sectors	Auto			
Spot Soundings	On			
Warn Depth	10.0			
Orientation	North Up			

- **Map Outlines**—On/Off: turns the coverage boxes for BlueChart/MapSource data on or off.
- **Symbol Set**—NOAA, International: controls the navaid symbol set.
- **Light Sectors**—Off, Auto, On: controls the drawing light sectors on the map.
- **Spot Soundings**—On, Warn Depth, Off: turns on the depth spot sounding data.
- **Warn Depth**—shows the spot sounding below the set value in red. This field is only available when **Warn Depth** is selected in the Spot Soundings field.

- **Orientation**—North up: fixes the top of the Map Page to a north heading. Track up: fixes the top of the Map Page to the current track heading. Course up: fixes the map so the direction of navigation is always up.

Detail Sub Tab

- **Chart**—Most, More, Normal, Less, Least: controls how much map detail is shown. This setting only applies to map features set to Auto. Features that have a specified zoom range or are turned off are unaffected by this setting.
- **Waypoints, Active Route, Tide Stations, Services, Saved Tracks, Track Log, and Lat/Lon Grid**—Auto, Off, 120 ft-800 mi: sets the maximum zoom range the feature should appear on the Map Page. Some types of data only show up to specific zoom ranges.

Labels Sub Tab

The Labels sub tab contains the screen size of the name or symbol of the listed feature. You can choose from None, Small, Medium, and Large.

Nav Sub Tab

Detail	Labels	Nav	AIS	Source
AutoZoom		Off		
Accuracy Circle		On		
Bearing Line		Off		
Course Line		Auto		
Heading Line		Off		

- **AutoZoom**—On, Off: when on, the map automatically adjusts the map zoom range to a lower range as you approach you destination point.
- **Accuracy Circle**—On, Off: toggles the circle on or off. The circle represents the approximate accuracy of the unit based on EPE, DOP, and basemap quality. Your location is within the circle.
- **Bearing Line**—On, Off: toggles the black/white line that points to the current navigation point.
- **Course Line**—Auto, Off, 120 ft-800 mi: sets the maximum zoom range at which the course line appears on the screen.
- **Heading Line**—On, Off: draws an extension from the end of the boat icon in the direction of travel.

AIS Sub Tab

Refer to [page 25](#) for more information on AIS.

Source Sub Tab



- **Basemap**—On, Off: turns the built-in base map on or off.
- **Advanced**—On, Off: turns all optional BlueChart/MapSource data loaded on the data card on or off. The Advanced option box shows a list of the optional BlueChart/MapSource data loaded on the data card. Each area is described by name and can be hidden if you do not want to show the data on the Map Page.

To show the Advanced Map Card Setup:

1. Highlight the **Advanced** option box, and press **ENTER**.
2. Use the **ROCKER** to scroll through the list of map family. Press **ENTER** to view all of the maps within a map family.
3. To select or hide a map, highlight the check box to the left of the name of a map. Press **ENTER** to select or hide the map. The map is selected and appears on the Map Page when a check mark appears in the box adjacent to the map.
4. To show detailed information and notes for each area, highlight a name, and press **ENTER**. To view the notes for that area, choose **Show Notes**. To scroll through the notes, highlight the notes, press **ENTER**, and use the **ROCKER** to scroll up, down, left, and right, or press **ADJ/MENU** and choose a scroll option.



NOTE: The Advanced Map information is only available when you have a data card with additional map data, such as BlueChart g2, installed in the unit.

Hiway (Highway) Tab

The Hiway tab contains screen settings for the 3D Highway Page. Refer to the “Highway Page” section on [page 33](#).

Temp (Temperature) Tab

The Temp tab shows the water temperature log. The temperature log requires input from a temperature transducer/sensor or from a connected NMEA device that provides temperature data. The most recent temperature measured shows on the far right side of the chart with the history trailing to the left. The dotted lines within the chart indicate intervals in the temperature scale and the duration of time.

The following settings are available:

- **Log and Graph Scale**—controls the temperature range for the log. Select Auto to have the unit automatically determine the best range, or select a span of 2, 4, 6, 8, or 10 degrees.
- **Log Duration**—controls the number of temperature readings shown on the log. Shorter time durations shows a greater number of log points. Use longer time durations to detect temperature trends, instead of immediate readings.

Sonar Tab

The Sonar tab contains setup options for the Sonar Page. The Sonar Page is not active if you do not have a transducer connected. Refer to the “Using Sonar” section on [page 72](#) for more information on sonar setup options.

	General Graph
Trip	Keel Offset
Celes	0.0'
Points	Auto Color Gain
Route	Dynacolor™
Track	Automatic Gain Level
DSC	Medium
Card	Automatic Scroll Speed Limit
Msgs	30.0'
Pages	Transducer Type
Map	Dual Frequency
Hiway	Calibrate Water Speed
Temp	
Sonar	
System	
Alarm	

System (System) Tab

The System tab controls system setting for beeper, speed filter, languages, system mode, and simulator controls, restores factory settings, shows software version, and prepares software update cards.



The following settings are available:

- **Beeper**—Off, Alarms Only, Key and Alarm: controls audible beeps.
- **Speed Filter**—Off, Auto, On: averages speed readings.
- **Language**—sets the language for the unit's on-screen text.
- **Automatic Backlight**—adjusts the backlight based on the built in sunrise and sunset information.

- **System Mode**—sets Normal or Simulator Mode. The Setup button allows you to simulate navigation.
- **Set Position***—sets your location while in Simulator Mode. See [page 3](#) for additional instructions.
- **Track Control***—Auto Track, User Track: controls your heading in Simulator Mode.
- **Track***—sets your heading in Simulator Mode.
- **Speed***—sets your speed in Simulator Mode.
- **Transducer***—sets a transducer type.

* These fields are only available when the unit is in Simulator Mode.

The following options are also available from the Systm tab:

- **System Information**—shows the unit's software, basemap version, and electronic serial number.
- **Prepare SW Update Card**—prepares a data card to accept software updates from your computer through the data card programmer.

Press **ADJ/MENU** for the following options:

- **Factory Defaults**—restores all settings to Garmin's original setup values for the entire unit.

Units Sub Tab

The Unit tab defines the Position Format, Map Datum, Heading, Distance, Speed, Elevation, Depth, Temperature, and Pressure units.

	General	Units	Time	Comm
Trip	Position Format			
Celes	hddd°mm.mmm'			
Points	Map Datum			
Route	WGS 84			
Track	Distance, Speed, and Elevation			
DSC	Nautical (nm, kt, ft)			
Card	Heading (HDG)			
Msgs	Auto Mag Var		003° E	
Posgs	Depth			
Map	Feet (ft)			
Hiway	Temperature			
Temp	Fahrenheit (°F)			
Sonar	Pressure			
System	Millibars (mb)			
Alarm				

The following settings are available:

- **Position Format**—changes the coordinate system. Only change the position format if you are using a map or chart that specifies a different position format or want to use a format you are familiar with.

For additional information on Loran TD setup, see [page 103](#).



NOTE: The Units tab settings affects how navigation information appears on the GPSMAP 392/398/492/498. When in doubt, seek assistance. If you are using a map or chart in conjunction with your GPS, make sure the settings under the Units tab of the GPSMAP 392/398/492/498 match that of the map or chart. This information should appear somewhere on the map or chart. If the information is not present, contact the map or chart maker to determine what position format, datum, heading and units of measure are being used for the map or chart.

- **Map Datum**—sets the datum reference used to determine a given location. The default setting is WGS 84. The unit automatically chooses the best datum depending on your chosen position format. Datums are used to describe geographic locations for surveying, mapping, and navigation. You should only change the datum if you are using a map or chart that specifies a different datum.



WARNING: Selecting the wrong map datum can result in substantial position errors. Unless otherwise specified by the navigation documentation you are using, use the default WGS 84 datum for best overall performance.

- **Distance, Speed and Elevation**—sets the units of measure for distance, speed, and elevation readouts in Nautical (nm, kt, ft), Nautical (nm, kt, m), Statute (mi, mh, ft), or Metric (km, kh, m) terms.
- **Heading**—sets the reference used in calculating heading information. You can select from **Auto Mag Var**, **True**, **Grid**, and **User Mag Var**. Auto Mag Var provides magnetic north heading references that are automatically determined from your current location. True provides headings based on a true north reference. Grid provides headings based on a grid north reference (and is used in conjunction with the grid position formats described on [page 70](#)). User Mag Var allows you to specify the magnetic variation at your current location and provides magnetic north heading references based on the variation you enter.

To enter a user-defined magnetic variation:

1. With the **Heading** field set to **User Mag Var**, highlight the heading reference field (immediately to the right), and press **ENTER**.
2. Enter the magnetic variation at your current location and press **ENTER**.



WARNING: If **User Mag Var** is selected, you must periodically update the magnetic variation as your location changes. Using this setting, the unit does not automatically calculate and update the magnetic variation at your present location. Failure to update this setting can result in substantial differences between the information shown on your unit and external references, such as a magnetic compass.

	General	Units	Time	Comm
Trip	Position Format			
Celes	hddd°mm.mmm'			
Points	Map Datum			
Route	WGS 84			
Track	Distance, Speed, and Elevation			
DSC	Nautical (nm, kt, ft)			
Card	Heading (HDG)			
Msgs	User Mag Var			
Pages	030			E
Map	Depth			
Hiway	Feet (ft)			
Temp	Temperature			
Sonar	Fahrenheit (°F)			
System	Pressure			
Alarm	Millibars (mb)			

Manually enter a magnetic variation.

- **Depth**—allows you to select the units of measure for depth in Feet (ft), Fathoms (fa) or Meters (m).
- **Temperature**—allows you to select the units of measure for temperature in Fahrenheit (°F) or Celsius (°C).
- **Pressure**—allows you to select units of measure for pressure in Inches Mercury (in), Millibars (mb), and Hectopascals (hPa).

Time Sub Tab

The Time tab shows the current time and date, allows you to adjust the 12 or 24 hour time format, enter a time zone, and adjust for daylight saving time.

The following options are available:

- **Time Format**—choose from 12 Hour, 24 Hour (military), or UTC time format.
- **Time Zone**—choose your correct time zone to show correct local time or select Other.
- **Daylight Saving Time**—choose from Auto, On, or Off to adjust for daylight saving time.

Comm (Communications) Sub Tab

The Comm tab controls the input/output format used when connecting your GPSMAP 392/398/492/498 to external NMEA devices, a PC, or another Garmin unit.

- **Garmin Data Transfer**—the proprietary format used to upload or download MapSource data, exchange waypoint, route, track, almanac, and proximity data with a PC or another Garmin unit. When you select Garmin Data Transfer, you can choose from 11 Transfer Modes: Host, Request Almanac, Request Proximity, Request Routes, Request Tracks, Request Waypoints, Send Almanac, Send Proximity, Send Routes, Send Tracks, and Send Waypoints.
- **Garmin Remote Sonar**—required for use with the GSD 22, GSD 21, or GSD 20.
- **NMEA In/NMEA Out**—supports the input/output of standard NMEA 0183 data, and sonar NMEA input support for the DPT, MTW and VHW sentences.
- **None**—provides no interfacing capabilities.

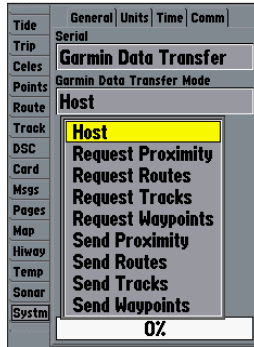

When transferring data between two Garmin units, always set one to Host and use the other unit to either Send or Request the data.

To select an input/output format:

1. Highlight the **Serial** field, and press **ENTER**.
2. Use the **ROCKER** to select a setting, and press **ENTER**.

To select a transfer mode:

1. Use the **ROCKER** to select **Garmin Data Transfer** in the **Serial Data Format** field.
2. Highlight the **Transfer Mode** field, and press **ENTER**.
3. Use the **ROCKER** to select a setting, and press **ENTER**.

Advanced NMEA settings to adjust the NMEA output are available if you have one of the ports set to NMEA In/NMEA Out. Advanced NMEA settings enable/disable certain sentences and adjust the number of Lat/Lon output precision digits.

To adjust the NMEA output:

1. From the **Comm** tab, highlight **NMEA Setup**, and press **ENTER**.
2. Highlight an option, and press **ENTER**.
3. Use the **ROCKER** to select a setting, and press **ENTER**. Press **QUIT** to return to the **Comm** tab.

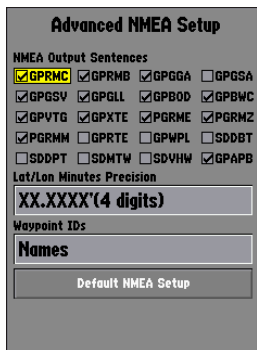

Advanced NMEA Output Setup Page

Alarm Tab

The Alarm tab allows you to define the alarm settings. The Alarm tab is divided into three sub tabs: System alarms, Nav alarms, and Sonar alarms.

System Sub Tab

- **Clock**—provides an alarm for the system clock. Enter a time in the time field, and turn the alarm on and off from the control field menu. Remember to enter alarm times in the same time format (UTC or local) you are using for your system. The unit must be on for the clock alarm to work.
- **Battery**—sets an alarm to sound when the power reaches a user-determined voltage.
- **GPS Accuracy**—the accuracy alarm sounds when the GPS position accuracy falls outside the user-set value.

Nav Sub Tab

- **Anchor Drag**—sets an alarm to sound when you have exceeded a specified drift distance. Enter a value in the distance field, and use the control field to turn the alarm on and off.

- **Arrival**—sets an alarm to sound when at specified distance or time away from a destination waypoint. Enter a distance radius or time for sounding the alarm and use the control field to set the alarm to **Off**, **Dist** (Distance), or **Time**.
- **Off Course**—sets an alarm to sound when you are off course by a specific distance. Enter a distance in the distance field and use the control field to turn the off course alarm on and off.

Sonar Sub Tab

You must be receiving sonar data for these functions to work. See “Using Sonar” on [page 72](#) for more information.

- **Shallow Water/Deep Water**—sets an alarm to sound when you enter an area of specified depth that is too shallow or too deep. Enter a depth in the distance fields and use the control fields to turn the alarms on and off.
- **Water Temperature**—sets an alarm to sound when the transducer reports a temperature either above, below, inside, or outside the specified values.
- **Fish**—sets alarm to sound when unit detects a fish of the specified symbol.

To set an alarm:

1. Press and hold **MENU** to open the Main Menu.
2. Use the **ROCKER** to highlight the **Alarm** tab and a sub tab.
3. Highlight the field you want to start, and press **ENTER**.
4. Use the **ROCKER** and **ENTER** keys to select and set the alarm you want.

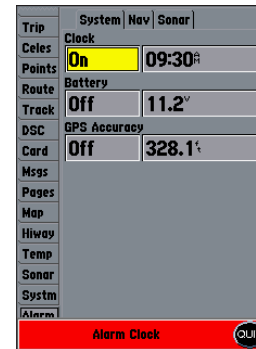

Press **QUIT** to acknowledge an alarm.

USING SONAR

This section covers the additional sonar options for the GPSMAP 398/498 when used with a transducer and the GPSMAP 392/492 when used with a GSD 22, GSD 21, GSD 20 and transducer. Read the *Installation Instructions* to properly install the GSD 22, GSD 21, or GSD 20 and transducer.



NOTE: You **MUST** have a transducer installed and connected to your GPSMAP 398/498 to use the sonar features.



NOTE: You **MUST** have a GSD 22, GSD 21, or GSD 20 and a transducer installed and connected to your GPSMAP 392/492 to use the sonar features. Ultrascroll is not available with the GSD 20.

Understanding Sonar

The transducer mounted on your vessel sends sound waves down into the water in a cone shape, similar to a flashlight beam (covering a smaller circular area at the top and angling out to a larger circular area at the bottom). These sound waves reflect off of any object that they hit, and then the waves travel back up to the transducer. These objects could be fish, branches, the bottom, or any other object that has a density that is different from the water. The transducer receives the sound wave information and then sends the information to the GSD 22, GSD 21, GSD 20 sounder module

and then to the GPSMAP 392/398/492/498. The GPSMAP 392/398/492/498 displays the information on the screen for you to see and interpret. The type of transducer and the settings that you choose determine how the information is displayed on the screen.

Using Dual Frequency

Dual frequency works best for deep water (off-shore) applications. The 200 kHz frequency allows you access to great detail about what is underneath your boat. The 50 kHz frequency provides less detailed information, but penetrates to greater depths with the same power. You can choose either or both frequencies to get the information that you want. If you choose dual frequency, the transducer alternates between the 50 kHz and 200 kHz signals. This capability allows you to see the best picture available at any depth.

Using Dual Beam

Dual beam works best for shallow water (for example, inland) applications. A dual beam transducer can transmit a narrow or a wide beam. The water area covered by the transmitted sound waves is determined by the beam width of the transducer and the water depth. The narrow beam provides crisp detail of what is under your boat, and is very helpful if you are fishing in deeper water where the beam covers more area (for example, at a 30-foot depth, the narrow beam covers the area of about a 7-foot circle).

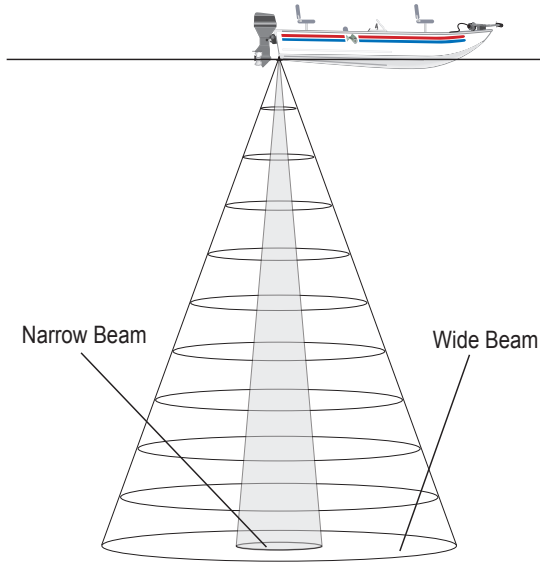

The wide beam is more helpful in shallow water, because it gives you a much wider view of objects in the water, including areas beyond the sides of your boat. At a 30-foot depth, the wide beam covers the area of approximately a 20-foot circle.

Understanding the Sonar Display

One of the first things to understand about sonar is that the transducer sends a beam down to the bottom of the water, much like the beam of a flashlight. The beam starts small near your vessel and expands as it gets to the bottom.

The Sonar Page does not show a 3-D representation of the underwater environment. Instead, the display is in two dimensions, much like if you took a picture of an aquarium. Only the depth of the item in the water is shown.

The strongest sonar returns appear on your screen as the most intense solid color (depending on your selected color scheme; red is the default). The weakest returns appear as the less intense, less solid colors (blue is the default).

The bottom of the water is always be the strongest signal, and therefore the most intense color. The bottom is the continuous, intensely-colored line running across the bottom of the screen. The GPSMAP 392/398/492/498 uses the latest technology in interpreting bottom signals; it can see through fish, structures, and thermoclines (shown in the weakest colors). However, large schools of fish or dense structures close to the bottom can affect water depth return readings.



NOTE: If the GPSMAP 392/398/492/498 is unable to track the bottom for any reason, the digits in the depth window flash on and off to alert you that the unit is not tracking the bottom.

At the top of the screen, you might see a grouping of intense colors. This area is surface clutter, which can be caused by waves or any other sonar interference at the surface of the water. Too much surface clutter can obscure your view of fish. You can turn down the Gain setting to reduce this surface clutter.

Between the bottom and the surface clutter, the fish appear as arches. Actual fish returns might not always appear as perfect arches, due to the speed, fish orientation, or other conditions. You can turn on the Fish Symbols setting if you want to see on-screen fish in a fish shape.

Sonar Page

The Sonar Page is where your GPSMAP 392/398/492/498 becomes a powerful fishfinder/flasher. To view the Sonar Page, press **PAGE** repeatedly until it shows. Fish are shown as colored arches or as fish icons. Thermoclines are shown as shades of blue. The sonar function window contains a right-to-left moving sonar image of the water beneath your boat. Items appear as they pass under the transducer. The most recent data is shown on the right side of the screen. The right side of the screen contains a scale reflecting the depth of the area being shown. The top-left corner shows the depth, water temperature, and speed through water (if equipped with a temperature or speed sensor).

Use the **Fish Symbols** option to view the actual sonar data, fish symbols, or a combination of both. Fish symbols appear as red.

You can set the sonar display to show a split screen view of a zoomed portion of the sonar, split frequencies, bottom lock (display scaled from the bottom up) or a combination of these options. For example, you can choose to show dual frequency at a 2X zoom (Dual 2X) on one half and normal range dual frequency (Dual) returns on the other half. The display mode appears at the bottom of each sonar display.

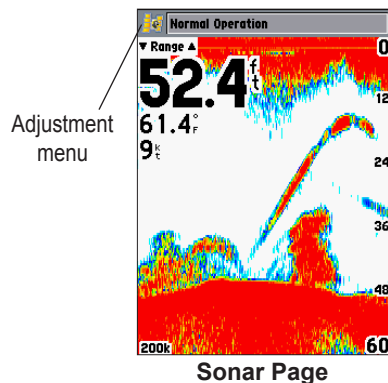

Using the Sonar Adjustment Menu

The Sonar Adjustment menu gives you direct access to the settings and features most commonly used on the Sonar Page. The option selected currently appears in the upper-left corner of the screen.

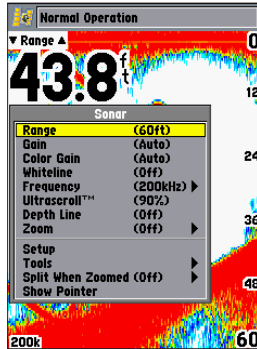

Press **ADJ/MENU** to see a list of all options and their current settings.

To select an adjustment option from the Sonar Page:

1. Press the **ROCKER** left or right to scroll through the options in the upper-left corner of the screen.
 2. Press **ENTER** to access the option's adjustment window.
- OR
1. Press **ADJ/MENU**. A list of all options and their current settings appears, with the selected option highlighted.

2. Press up or down on the **ROCKER** to select the option, and press **ENTER** to access the adjustment window.
3. To exit any of the adjustment options, press **QUIT**.

To change a Sonar Adjustment menu setting:

1. Select an adjustment option to change using one of the two methods described previously. The adjustment window automatically times out and disappears when the unit is idle for 20 seconds.
2. Press the **ROCKER** up or down to place the map pointer or setting bar at the setting, range, or percentage (Off, 1-100%).
3. Press **ENTER** or **QUIT** to exit the adjustment window, or press left or right on the **ROCKER** to view another adjustment window.

Range—sets the screen depth range used for viewing. The unit can be set to automatically track the bottom or set to a user-specified depth range. Auto mode shows the most information possible while continuously showing the bottom.

Gain—controls the sensitivity of the sonar receiver. **Auto** (default) is the recommended setting. It automatically sets the sonar sensitivity. You can also set the gain manually. To see more detail on the screen, increase the receiver sensitivity by selecting a higher gain. If there is too much detail or if the screen is cluttered, lower the sensitivity (lower the gain) to increase the clarity of the screen.

If Frequency is set to **Dual**, you can set the Gain separately for each frequency (50 kHz and 200 kHz).

Color Gain—controls what colors are applied to the objects on the screen. **Auto** (default) is the recommended setting. It automatically sets the colors, based on your Auto Color Gain setting. You can also set the Color Gain manually. If Frequency is set to **Dual**, you can set the Color Gain separately for each frequency (50 kHz and 200 kHz).

Whiteline—controls how the unit shows information about the bottom type (hard or soft). With the Whiteline Off, the bottom return shows as red and contains no information on bottom hardness. With Whiteline set at Normal or 1-100%, the bottom return becomes white with a red line, in the default color scheme, indicating where the water meets the bottom. To turn the Whiteline Off, press the **ROCKER** down until the setting bar is all the way at the bottom of the range and reads **Off**.

Frequency—only appears when using a dual frequency transducer. This allows you to choose a sonar operation frequency. You can choose **200 kHz**, **50 kHz** or **Dual** frequency (to alternate between the two frequencies).

UltraScroll/Scroll—adjusts the rate at which the Sonar Pages scroll from right to left. **Ultrascroll™** (default) is used when you select a scroll rate from 90% to 100%. **Auto** automatically adjusts the scroll rate according to the boat's speed.

Depth Line—adds a horizontal depth line across the screen that is used to measure the depth of underwater objects. The depth of the line appears on the right side of the line. Press up or down on the **ROCKER** to control the position of the line on the Sonar Page. To turn the Depth Line off, press the **ROCKER** up until the setting bar is all the way at the top of the range and reads **Off**.

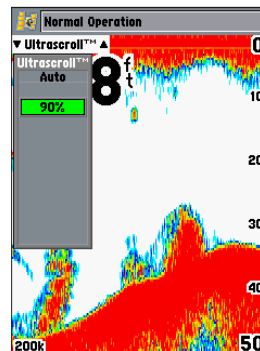

Zoom—sets a screen zoom scale. The following settings are available:

- **Off**—turns off the Zoom function.
- **2x Zoom**—displays the 2x zoomed picture.
- **4x Zoom**—displays the 4x zoomed picture.
- **Btm (Bottom) Lock**—displays returns from the bottom up. When using this setting, “BL” appears at the bottom of the screen.

Zoom View—available when you select a Zoom scale other than **Off**. You can use the Zoom View setting to change the viewing range of a zoomed display. **Auto** follows the water bottom. If the display is set to **Bottom Lock**, the Span setting adjusts how far off the bottom the unit shows data.

Tools—controls the display of useful sonar tools. The following options are available:

- **A-scope**—when you turn on A-scope, a vertical flasher bar appears on the far-right side of the screen. This flasher displays structure and bottom returns much the same as the Flasher Page. The horizontal width of the A-scope signal indicates the strength of the signal.
- **Color Bar**—shows a gradient scale of the current Color Gain setting.
- **Temperature Graph**—appears only if you have a temperature-capable transducer. When on, this setting displays a temperature graph on the bottom of a Sonar Page that matches the scrolling data.

Split When Zoomed—turns this option on or off. If you turn on Zoom, then this setting splits the screen.

Swap Split—available on a split Sonar Page when you are using dual frequency. This switches on which side the frequencies appear.

Show/Hide Pointer—allows you to reference sonar items and mark underwater waypoints. This makes it easier to find and use an object such as a stump for a future fishing location. When using this feature, the Sonar Page pauses. The map pointer does not move off the paused screen and cannot show an area that has scrolled off the screen. The depth is updated while the screen is paused, but the unit does not show any new sonar data until the standard Sonar Page is resumed. You can see a discontinuity from where the sonar information stops to where it starts again.

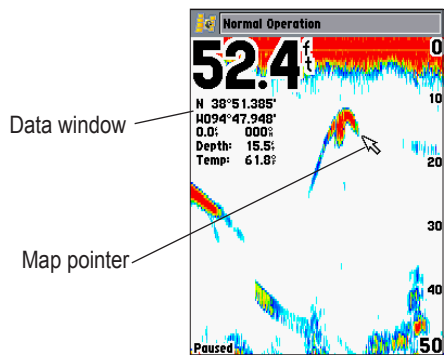

Show Map Pointer Option

To mark an underwater waypoint:

1. From the Sonar Page, press **ADJ/MENU**, highlight **Show Pointer**, and press **ENTER** to pause the screen movement.
2. Use the **ROCKER** to move the cursor onto the target, such as underwater drop-offs and stumps, you want to mark. The data window at the top of the screen shows the cursor's depth, coordinates, bearing and distance from your current position.
3. Press **ENTER/MARK**. The New Waypoint Page appears with the waypoint's coordinates, default three-digit name, and map pointer depth automatically filled in.
4. To change the name, symbol, water temp, or depth, highlight the appropriate field and press **ENTER**. Make your changes and press **ENTER** when finished.
5. When finished, highlight **OK**, and press **ENTER**.
6. To return to the standard Sonar Page, press **QUIT**; or press **ADJ/MENU**, highlight **Hide Pointer**, and press **ENTER**.

Sonar Tab Options

When a GSD 22, GSD 21, or GSD 20 is connected to the GPSMAP 392/398/492/498, the Sonar tab appears on the Main Menu.

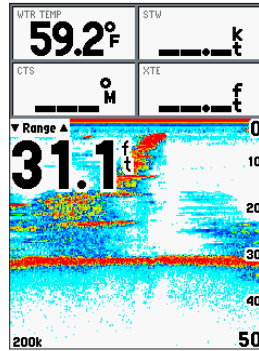

Show Numbers Option

To access and change a setting on the Sonar tab:

1. Press and hold **ADJ/MENU** to access the Main Menu. Use the **ROCKER** to highlight the **Sonar** tab.
2. Using the **ROCKER**, highlight the sub tab and then the field, and press **ENTER**.
3. Highlight the setting, and press **ENTER**.
4. Press **QUIT** to return to the Sonar Page or a previous page.

General Sub Tab

Use the **General** sub tab to select the keel offset, auto color gain, automatic gain level, automatic scroll speed limit, and transducer type. The available General sub tab options are as follows:

Keel Offset—used to offset the surface reading for the depth of a keel. This makes it possible to measure depth from the bottom of your keel instead of from the transducer’s location. Enter a positive number to offset for a keel, or enter a negative number to compensate for a large vessel that can draw several feet of water. The Keel Offset reflects in the depth reading.



Keel Offset:
Transducer at
Surface Enter (+)
a positive number
to show depth from
bottom of keel.

Keel Offset: Transducer
at Bottom of Keel.
Enter a (-) negative
number to show
depth from surface.



Auto Color Gain—controls what colors are applied to the objects on the screen. **Color DCG** is based on depth and makes it easier to spot subtle changes in bottom conditions or fish sizes. **DynaColor** (default) represents the latest in sonar data presentation and is recommended for all applications. The presentation is based on bottom strength. It makes the bottom and the fish easier to see and requires fewer adjustments.

Automatic Gain Level—controls the aggressiveness of the Auto Gain. The higher the setting, the greater the number of targets appear on the screen. The lower the setting, the less clutter on the screen. The settings are **Low**, **Medium** (default), and **High**.

Automatic Scroll Speed Limit—automatically adjusts the Scroll rate (see [page 76](#)) with the speed of your vessel. Entering your maximum cruising speed produces a 100% scroll rate when you reach that speed. One half of that speed produces a 50% scroll rate, and so on. The default is **30.0 kt**.

Transducer Type—allows you to specify what type of transducer you are using, either **Dual Beam** or **Dual Frequency**.

Calibrate Water Speed—this appears only if you are using a speed-capable transducer/sensor. Calibration is required to ensure that the Water Speed shown on your unit is accurate. The unit automatically uses GPS ground speed for comparison on the calibration. If a GPS ground speed is not available, use either your boat's speedometer reading (not always accurate) or a stopwatch to determine your speed over a certain distance (distance / time = speed). It is recommended that the calibration take place in water having little or no current.

To calibrate the water speed:

1. Use the **ROCKER** to highlight **Calibrate Water Speed**, and press **ENTER**.
2. Bring the boat to a cruising speed. Both the top GPS ground speed and uncalibrated water speed appear at the bottom of the calibration window. Note your top speed, stop the boat, and press **ENTER**.
3. By default, the top speed automatically appears in the **What was your top water speed?** field. If a ground speed is not available, the top uncalibrated water speed is used instead. If the new speed is correct, highlight **OK**, and press **ENTER**. If you want to manually enter a calibration, press **ENTER** on the speed field, enter a new speed, and press **ENTER**.



NOTE: If the boat is not moving fast enough or the speed sensor is not registering a speed, a “Boat Is Not Moving Fast Enough To Calibrate” message appears at the bottom of the screen. Check that the speed sensor wheel is moving or safely increase boat speed. If there is a problem with the speed sensor, or if a speed sensor is not installed, a “Water Speed Sensor Is Not Working” message appears at the bottom of the screen. Check the connections of the speed sensor cables.

Graph Sub Tab

The available Graph sub tab options are:

- **Fish Symbols**—sets how the Sonar Page interprets suspended targets and background information. If you select a fish symbol, the GPSMAP 392/398/492/498 identifies some returns for you by replacing them with fish symbols (in large, medium, and small sizes based on the size of the sonar return). If you are using dual beam, fish symbols from the narrow beam (directly underneath your boat) are solid, and the returns from the wide beam (out to the sides of your boat) are hollow.

Off

The Sonar Page does not interpret the sonar return data.



Suspended targets appear as symbols. No background information appears



Same as previous with the target depth shown.



Suspended targets appear as symbols. Background information appears, making the distinction between fish and structure easier.



Same as previous with target depth shown.

- **Scale**—controls the appearance of the depth scale shown vertically along the right side of the graph. You can configure the depth scale to appear in one of four different ways: as an **Overlay**, in the **Corners**, **Basic**, or **No Scale**.
- **Water Temperature Number** and **Water Speed Number**—hides or shows temperature and water speed on the Sonar Page. When set to **Auto**, the unit automatically shows this information, only if it is received from the transducer.
- **Color Scheme**—sets the colors for the Sonar and Flasher Pages.



NOTE: If the unit is unable to track the bottom for any reason, the digits in the depth window flash on and off to alert you that the unit is not tracking the bottom.

Transducer Coverage

The area covered by the transmitted sound waves is determined by the cone angle of the transducer and the water depth. The wide cone angles (40°) associated with low frequencies (50 kHz/80kHz) provide a large coverage area for finding fish within a coverage width that is approximately 2/3 of the water depth. However, this also means that wide cone angles produce less bottom detail and resolution. As shown in the drawing on [page 73](#), the 40° cone angle produces a coverage area of approximately a 20-foot diameter circle at a 30-foot depth.

The narrow cone angles (10°) associated with the high frequencies (200 kHz) provide better bottom resolution and crisper detail, but cannot show a large coverage area for finding fish. The 10° cone angle provides a coverage width that is approximately 2/10 of the water depth. As shown in the drawing on the far right, the 10° cone angle produces a coverage area of approximately a 6-foot diameter circle at a 30-foot depth.

Dual frequency or dual beam modes combine both frequencies to get the best coverage area and contour/depth readings.

Whiteline

When the sonar sound waves are reflected back by the bottom, a hard bottom returns a stronger signal than a soft bottom. A thin whiteline indicates a softer bottom, while a thick whiteline indicates a harder bottom. Normally, a red line is used to show the point where water meets the bottom. This line follows the bottom contour, along with any significant objects lying on the bottom. The unit uses the whiteline function to make the bottom layer information easier to distinguish. These images show the Classic Black color scheme.

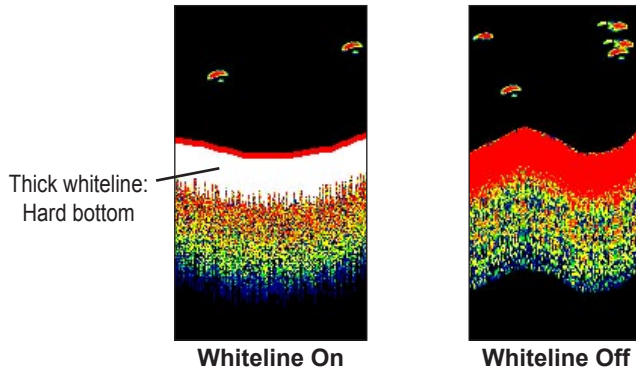

Thermoclines

A rough definition of a thermocline is a break in water where the water temperature changes faster than the water above it. Thermoclines are shown as the weakest colors.

One of the unique features offered by Garmin is See-Thru[®] technology, which allows the GPSMAP 392/398/492/498 to hear both weak and strong signals simultaneously so as to identify fish returns under the toughest conditions, such as suspended in thermoclines or even hiding near structures. See-Thru technology allows the transducer to see through thermoclines and locate fish. This image is in the Classic Black color scheme

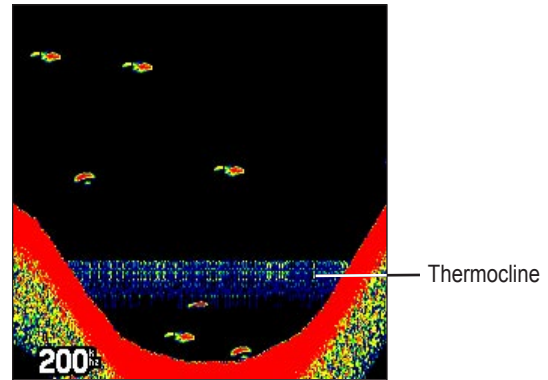

Flasher Page

The Flasher page provides an almost instantaneous return of what is below your boat. This page can show depth, fish, bottom content, and structure. When you use the Flasher page, you can adjust the Range, Gain, Color Gain, Frequency, and Scroll settings. See [page 79](#) for information about these settings and how to change them.

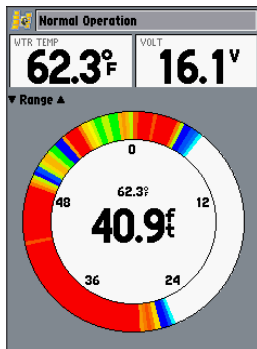

Flasher Page

Understanding the Flasher Page

The most intense, constant signal on the Flasher Page is the actual depth and bottom:

- A **soft bottom** (such as silt or mud) creates a signal that is narrow and more faint.
- A **hard bottom** (such as sand or rock) creates a signal that is wider.

The colors indicate the different strengths of the signals. If you understand a bit about how sonar works, you can better understand what you see on the Flasher Page. Remember, three-dimensional space is appearing on a two-dimensional screen. The circular area of the bottom becomes a wide mark on the screen and fish inside the transducer beam can be any color and in any position, including inside and beyond the bottom mark. The colors indicate the different strengths of the signals. This can be roughly correlated to a position inside the beam. Red being the center most part, orange the area around, and green the outer edge of the beam. Targets (for example, fish) with larger surface area appear more red; and targets with less surface area appear orange, and green for the smallest items.

The fish mark itself holds a lot of information. You can tell if fish are bigger or smaller, because the thickness of the red mark correlates to the thickness of the fish.

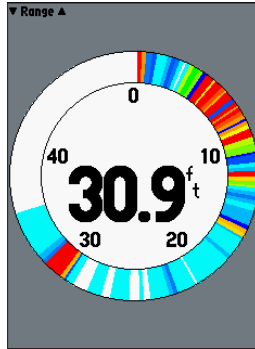

Flasher Page Without Data Fields

Map Split Page

The Map Split Page is horizontally divided into two main areas, the Map and the Sonar. This page only appears if the unit is receiving sonar information. Refer to [page 27](#) for information on the Map and [page 74](#) for the Sonar information.

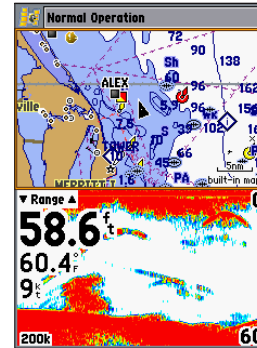

Map Split Page

APPENDIX

Specifications

Physical Specifications

Size: (Internal Antenna) 6.2" H x 6.30" W x 3.14" D
 (15.7 cm x 16.0 cm x 8.0 cm)
 (External Antenna) 6.2" H x 6.30" W x 3.26" D
 (15.7 cm x 16.0 cm x 8.3 cm)

Weight: Less than 2.0 lb

Display: 5.0" diagonal (12.7 cm) 256-color TFT display with backlighting (234 x 320 pixels)

Case: Fully gasketed, high-impact plastic alloy, waterproof to IEC 529-IPX-7

Temp. Range: 5°F to 158°F (-15°C to 70°C)

Performance

Receiver: Differential-ready 12 parallel channel WAAS-capable receiver

Acquisition Times:

Warm: Approx. 15 seconds

Cold: Approx. 45 seconds

AutoLocate: Approx. 2 minutes

Update Rate: 1/second, continuous

GPS Accuracy:

Position: <15 meters (49 feet), 95% typical*

Velocity: 0.05 meters/sec steady state

WAAS Accuracy:

Position: <3 meters (10 feet), 95% typical*

Velocity: 0.05 meters/sec steady state

Dynamics: 6gs

* Subject to accuracy degradation to 100 m 2DRMS under the U.S. DOD-imposed Selective Availability Program.

Power

Source: 10-33 V DC

Usage: 14 watts max. at 13.8 vDC

Fuse: AGC/3 AG-3 Amp

Sonar

Sounder Power: 500 watts (RMS)
 4,000 watts (peak to peak)

Dual Frequency: 50/200 kHz (40°/10°) frequency
 1,500 foot max depth*

Dual Beam: 80/200 kHz (40°/14°) frequency
 900 foot max depth*

* Depth capacity is dependent on water salinity, bottom type, and other water conditions.

Installing the GPSMAP 492/498 External GPS Antenna

The GPSMAP 492/498 with external antenna must be properly installed according to the following instructions to get the best possible performance. To complete the external antenna installation, you need the appropriate fasteners and a 1" x 14-thread marine antenna mount available at most marine dealers.

The GPSMAP 492/498 with internal antennas do not require this installation. To acquire satellites, install the unit with a clear view of the sky.

Mounting the GPS Antenna (External Antenna Units Only)

The antenna should be mounted in a location that has a clear, unobstructed view of the sky in all directions to ensure the best reception. Avoid mounting the antenna where it is shaded by the boat's superstructure, a radome antenna, or mast. Sailboat users should avoid mounting the antenna high on the mast to prevent inaccurate speed readings caused by excessive heeling. Most marine VHF and LORAN antennas should not seriously degrade the GPS antenna's reception. Never paint the antenna or clean it with harsh solvents.

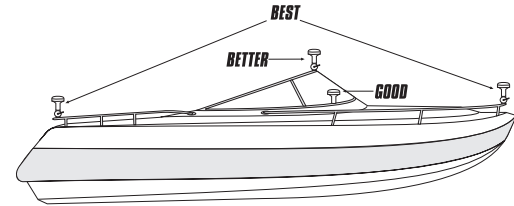

Suggested locations for mounting the external antenna.

The Garmin antenna screws directly onto any standard 1" x 14-thread antenna mount. If you need to raise the antenna to avoid shading, try using a 1" x 14-thread extension mast available at most marine dealers.



NOTE: It is possible to route the coaxial cable either through, or outside the antenna mount. It is possible to remove the BNC connector on the coaxial cable and the coaxial cable shortened to ease installation, however, doing so voids the antenna warranty. If the BNC connector is removed, it must be replaced with a new solder-on or crimp BNC connector.



To install the GPS antenna:

1. Screw the antenna directly onto the 1" x 14-thread mount.
2. Route the cable to the mounting location of the unit. Use the appropriate tie-wraps, fasteners, and sealant to secure the cable along the route and through any bulkhead or deck.
3. After the GPSMAP 492/498 unit is installed, connect the cable to the antenna connector on the back of the unit. Make sure that you turn the antenna cable connector 1/4 turn clockwise to lock the cable into place.

Mounting the GPSMAP 392/398/492/498***Using the Swivel Bracket Mount***

The GPSMAP 392/398/492/498's compact, waterproof case is suitable for mounting in exposed locations or at the nav station.

The unit comes with a single-knob tilt & swivel bracket that can be used for surface or overhead mounting.

When choosing a location for the display unit, make sure you consider the following conditions:

- There should be at least a 3" (7 cm) clearance behind the case to allow connection of the antenna (external antenna only), power/data cables.
- The mounting surface should be heavy enough to support the unit and protect it from excessive vibration and shock.
- For GPSMAP 392/398/492/498 unit's with the built-in internal antenna, should be mounted in a location that provides a clear, unobstructed view of the sky in all directions to ensure the best reception. Avoid mounting the unit where it is blocked by the boat's superstructure, a radar arch, or mast.



NOTE: The temperature range for the GPSMAP 392/398/492/498 is 5°F to 158°F (-15°C to 70°C). Extended exposure to temperatures exceeding this range (in storage or operating conditions) can cause failure of the screen. This type of failure and related consequences are NOT covered by the manufacturer's limited warranty.

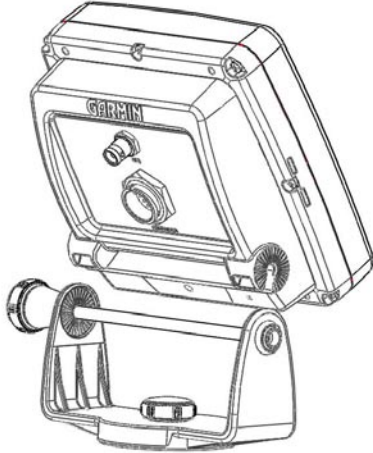

Tools (not included)—Drill, Screwdriver (Phillips or Standard), three #8 (4 mm) pan head machine bolts with matching nuts and washers and a 5/32" (5 mm) drill bit, OR three #8 pan head self-tapping screws and an appropriately-sized drill bit for drilling starter holes. Always wear safety goggles, ear protection, and a dust mask when drilling, cutting or sanding.



The swivel base is designed to be secured using a pan head screw or machine bolt. If you use a screw with a countersunk head, you risk damaging the Mounting Base.

To install the GPSMAP 392/398/492/498 swivel base:

1. Using the swivel base as a template, mark the location of the three holes that are used to secure the bracket to the mounting surface.
2. If securing the base with machine bolts, drill three 5/32" (5 mm) holes at the locations you marked.
OR
If you are securing the base with self-tapping screws, drill starter holes at the locations you marked. Starter holes should generally be no deeper than half the screw length.
3. Secure the swivel base with three bolts or screws.
DO NOT OVERTIGHTEN.
4. Place the rest of the mount over the swivel base and secure with the short knob.

Flush Mounting the GPSMAP 492/498 (External Antenna only)

The GPSMAP 492/498 with external antenna can be flush mounted on a flat panel. When flush mounting the GPSMAP 492/498, be sure to choose an appropriately sized location for the unit (see unit dimensions on [page 86](#)) and leave 1.25" (32 mm) clearance below the data card slot for inserting or removing data cards. A Flush Mount Template is provided in the package. Use the instructions on the template to complete the flush mount installation.

Installing the Transducer

The transducer acts as the eyes and ears of your new sonar. Proper transducer installation is critical to the operation of your unit. The transducer transmits sound waves toward the bottom in a cone shape. The larger the cone angle, the larger the coverage area at a given depth.

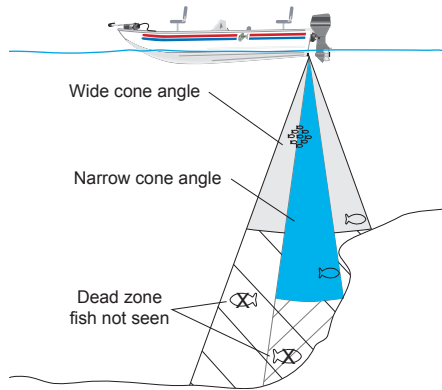

A wide cone angle transducer works best in shallow water. The wide cone angle provides a large coverage area, but at a decreased bottom resolution. In deeper water this can result in a large dead zone where fish cannot be seen. A narrow cone angle transducer is better suited to deep-water installations. The narrow cone angle provides a smaller viewing area (compared to a wide cone angle transducer at the same depth) with improved bottom resolution and a smaller dead zone. Dual frequency transducers give you the best of both wide and narrow cone angles.

A 50/200 kHz dual frequency 40°/10° cone angle, temperature sensing, transom mount transducer is included in the GPSMAP 498 (with transducer) package. This transducer provides good all-around performance.

A 80/200 kHz dual beam 40°/14° cone angle, temperature sensing, transom mount transducer is included in the GPSMAP 398 (with transducer) package. This transducer provides good all-around performance.

Transom Mount Transducer

The following diagram is for mounting the transducer included with the GPSMAP 392/398/492/498 with transducer package. If the transducer lead is too short, extension cables are available from your Garmin dealer. **DO NOT** cut the transducer lead or any part of the transducer cable, as this will void your warranty. The cable cannot be spliced and connected to any existing (Garmin or non-Garmin) transducer cables.



NOTE: DO NOT mount the transducer behind strakes, struts, fittings, water intake, or discharge ports, or anything that creates air bubbles or causes the water to become turbulent. It is important that the transducer is in clean (non-turbulent) water for optimal performance.

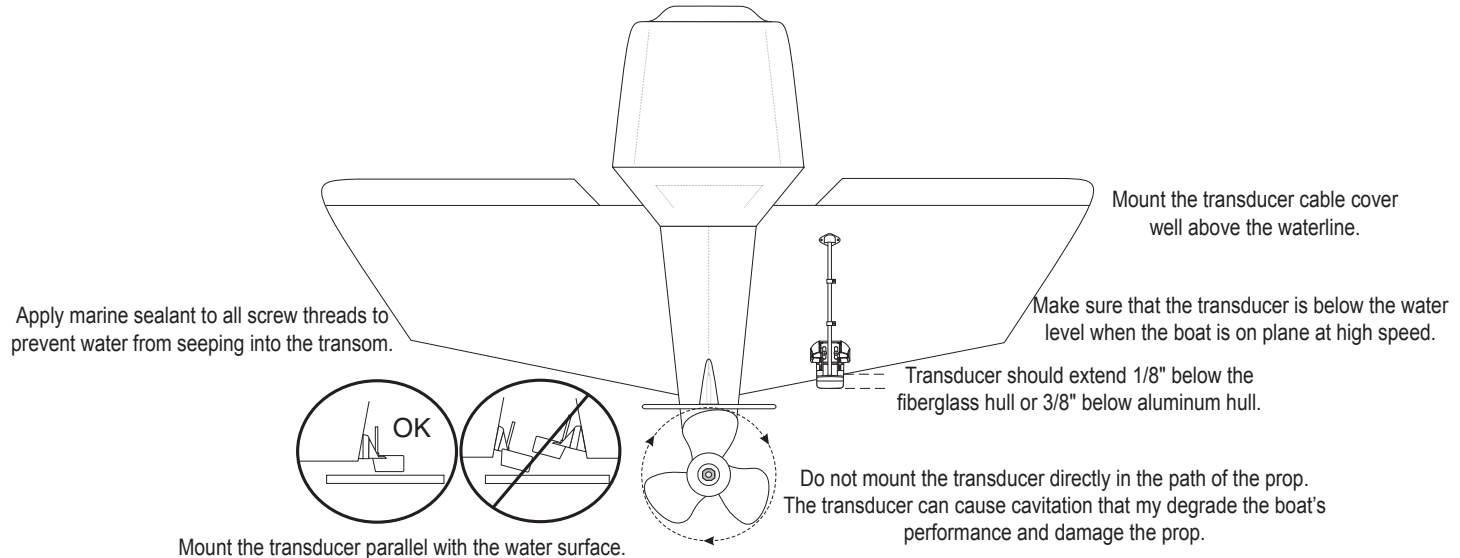

Connecting the Power/Data Cable

The power/data cable connects the GPSMAP 392/398/492/498 to a DC supply and provides interface capabilities for connecting external devices. The color code in the diagram below indicates the appropriate harness connections. Replacement fuse is a AGC/3AG - 3 Amp fuse.



NOTE: CANet wiring diagrams are provided with the CANet accessory.



NOTE: During a typical installation, only the Red and Black wires are used. The other wires do not have to be connected for normal operation of the unit.

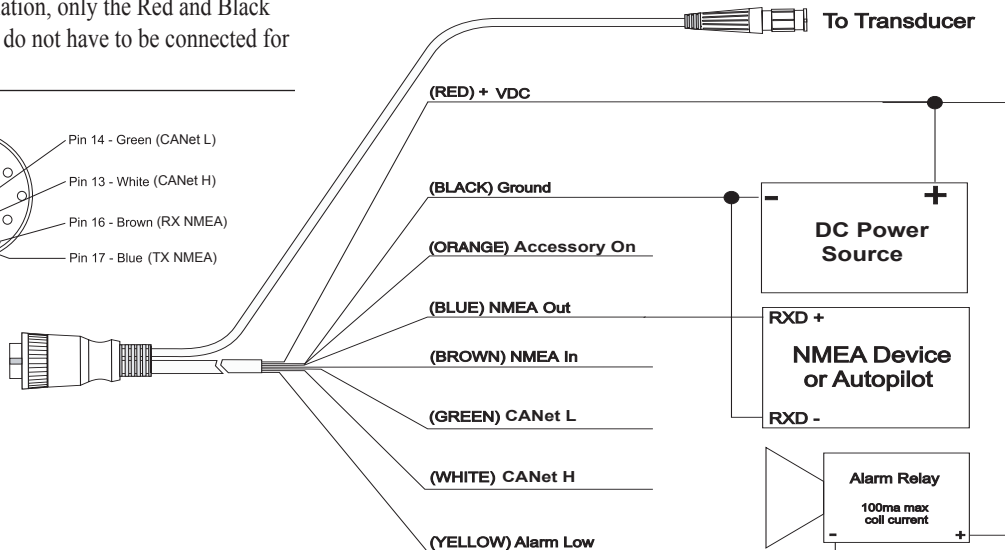
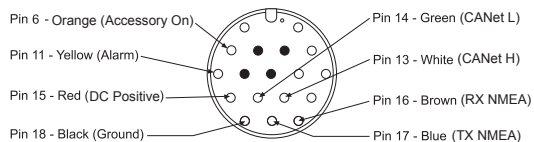

Interfacing

The following formats are supported for connection of external devices:

The following are the sentences for NMEA 0183, vs. 3.01 output:

Approved sentences—GPRMC, GPRMB, GPGGA, GPGSA, GPGSV, GPGLL, GPBOD, GPBWC, GPVTG, GPRTE, GPXTE, GPWPL, SDDBT, SDDPT, SDMTW, SDVHW, and GPAPB.

Proprietary sentences—PGRME, PGRMM, and PGRMZ. The GPSMAP 392/398/492/498 accepts NMEA input with support for the DBT, DPT, MTW, VHW, and WPL sentences.

You can download a copy of Garmin's proprietary communication protocol on the Help and Support section of our Web site at www.garmin.com.

Complete information regarding NMEA format is available for purchase at www.nmea.org

Installing and Removing Data Cards

The GPSMAP 392/398/492/498 uses optional Garmin marine BlueChart g2 and MapSource data cards to show digital charts and maps on-screen. Data cards are installed in the card slot located at the bottom right of the unit. Data cards can be installed or removed at any time, whether the unit is on or off.

To install a data card:

1. Open the card door by pressing together on the two handles at the bottom of the door and lifting it up and open.
2. Insert the card, with the label facing front and the handle bottom, into the slot.
3. Firmly push the card into the unit. It is not necessary to force the card and about 1/2" is still exposed when it is properly inserted. If the unit is on, a confirmation tone sounds and a message shows on-screen noting the card details when the card is properly installed and accepted.
4. Close the cover.

If you insert a data card and get a “card format not recognized” message, try removing the card and reinserting it. If the card is still not recognized, contact Garmin Support or your Garmin dealer for assistance. Data cards are not waterproof and should not be exposed to moisture or excessive static charges. Data cards should be stored in the case supplied with the card.

To remove a data card:

1. Open the card door by pressing together on the two handles at the bottom of the door and lifting it up and open.
2. Grasp the card handle at the bottom and pull down firmly.
3. If the unit is on, a confirmation tone sounds when the data card has been removed.



The first time you insert a data card, the unit takes a few seconds to read the card.

After the data card is read, a summary screen appears. Press **ENTER** to acknowledge.

Satellite Information

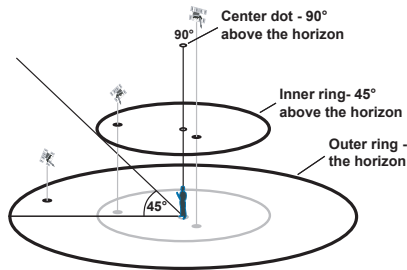

Satellite Sky View

Satellite Location

The location of each available satellite shows over two location rings on the Satellite Information Page. The outer ring represents the horizon, the inner ring represents 45° above the horizon, and the center represents directly overhead. When the unit is using a satellite for navigation, the satellite number is highlighted on the location rings. The unit can be set to show satellite location with North or your current track at the top of the screen.

Satellite Strength Indicator Bars

The Satellite Strength Indicator Bars show the strength of the signal being received, and the status of the signal. The bars are either shaded or filled. The gray bar means the GPS is in the process of storing orbital data it is receiving from the satellite signal. When the bar turns solid, the GPS is using the satellite signal for navigation. A “D” in or above the bar means that differential corrections (WAAS) is being applied to that satellite.

Date, Time, and Current Location

The GPS gets date and time information from the satellite’s on-board atomic clock. When the GPS receiver has achieved a GPS location, the current location appears in the selected location format.

What is WAAS/EGNOS?

The Wide Area Augmentation System (WAAS) is an FAA funded service to improve the overall integrity of the GPS signal for users in North America. In Europe, WAAS is referred to as EGNOS.

The system is made up of satellites and approximately 25 ground reference stations positioned across the United States that monitor GPS satellite data. Two master stations, located on either coast, collect data from the reference stations and create a GPS data correction message.

According to the FAA's Web site, testing of WAAS in September 2002 confirmed an accuracy performance of 1-2 meters horizontal and 2-3 meters vertical throughout the majority of the continental United States and portions of Alaska.

WAAS is just one service provider that adheres to the MOPS (Minimum Operational Performance Standard) for global Satellite Based Augmentation Systems (SBAS). Eventually there will be several services of worldwide geostationary communication satellites that broadcast integrity information and differential correction data as transmitted by ground reference stations.

All SBAS systems use the same receiver frequency; therefore any operational SBAS system should be capable of providing your GPS unit with increased accuracy at any location in the world.

Currently, enabling WAAS on your GPSMAP 392/398/492/498 in regions that are not supported by ground stations, may not improve accuracy, even when receiving signals from an SBAS satellite. In fact it can degrade the accuracy to less than that provided by GPS satellites alone. For this reason, when you enable WAAS on your Garmin GPS receiver, the receiver automatically uses the method that achieves the best accuracy.

For more information, go to <http://gps.faa.gov>.

What is a Maritime Mobile Service Identity (MMSI)?

Maritime Mobile Service Identity (MMSI) allows a VHF radio to act like a phone. In order to make a “call” on a phone, you first need a phone number to dial. The 9-digit MMSI number acts like a phone number when used in a position report and as a unique identifier to the Coast Guard when used in an emergency Distress Call. In order to obtain a MMSI number, users must register their VHF radio with the FCC (Form 605). Garmin does not supply this number.

How ARE MMSI assignments obtained?

Non-commercial users (for example, recreational users who remain in domestic waters and only carry VHF, EPIRB (Emergency Position Indicating Radio Beacons), and Radar) are not required to have a FCC ship station license. The FCC and Coast Guard have authorized some second and third party vendors to assign MMSI numbers. This service is limited to registering recreational vessels only. To receive information on how to obtain a recreational MMSI number, contact: www.uscg.mil/rescue21/links/mmsi.htm or <http://wireless.fcc.gov/marine/>.

US Non-Federal User: Commercial users, or those who travel outside the U.S. or Canada, must apply for a ship station license, or an amendment to a ship station license. To find out if you require a Ship Station license contact: <http://wireless.fcc.gov/marine/fctsht14.html>. If your vessel requires licensing by the FCC you obtain a MMSI during the application/licensing process when you file FCC Forms 159 and 605.

US Federal User: Federal users can obtain MMSI assignments from their agency radio spectrum management office. These procedures are currently under review by the NTIA (National Telecommunications and Information Administration).

Outside the US: Users can obtain an MMSI assignment from their telecommunications authority or ship registry, often by obtaining or amending their ship station license.

In Canada: Industry Canada is responsible for assigning MMSI numbers to commercial and recreational vessels. Information is available at the following web site: <http://apollo.ic.gc.ca/english/mmsi.html>.

For information regarding MMSIs visit:
www.navcen.uscg.gov/marcomms/gmdss/mmsi.htm.

Navigation Terms

Avg Speed—the average of all second-by-second speed readings since the last reset.

Bearing (BRG)—the compass direction from your current location to a destination.

Course—the course between the active from and to waypoints.

Depth—the depth below the transducer. This field is active only if a transducer is connected to the GPSMAP 392/398/492/498.

Distance (Dist)—the distance from the current location to a destination.

Dist to Destination—the distance from the current location to a Go To destination or the final waypoint in a route.

Dist to Next—the distance from current location to a Go To destination or the next waypoint in a route.

DOP (Dilution of Precision)—reflects the quality of the GPS signals and satellite geometry.

Elevation—height above mean sea level (MSL).

ETA (Estimate Time of Arrival)—the time you estimate to reach your destination waypoint, based on current speed and track.

ETA at Destination—the time you estimate to reach a Go To destination or the final waypoint in a route.

ETA at Next—the time you estimate to reach a destination or the next waypoint in a route.

Fuel—the fuel required to travel from current location to the indicated route waypoint.

GPS Accuracy—estimated accuracy of the GPS location.

Leg Dist—the distance between two route waypoints.

Leg Fuel—the fuel required to travel from a route waypoint to the next waypoint (in sequence) in the route.

Leg Time—the time required to travel from a route waypoint to the next waypoint (in sequence) in the route.

Max Speed—the maximum second-by-second speed recorded since last reset.

Moving Average Speed—average speed while the unit is moving.

Moving Trip Timer—total time the unit has been moving.

Odometer—a running tally of distance travelled, based on the distance between second-by-second position readings.

Off Course—the distance you are off course in either direction, left or right.

Map Pointer—an arrow pointing to your destination.

Speed—the current velocity at which you are travelling, relative to a ground position. Also referred to as ground speed.

Sunrise—the time at which the sun rises.

Sunset—the time at which the sun sets.

Time Of Day—the current time.

Time To—the estimated time required to reach a Go To destination, or the next waypoint in a route. Also known as “estimated time en route.”

Time to Dest—the estimated time required to reach a Go To destination, or the final waypoint in a route.

Time to Next—the estimated time required to reach a Go To destination, or the next waypoint in a route.

To Course—the recommended direction to steer to reduce course error or stay on course. Provides the most efficient heading to get back to the course and proceed along your route.

Track—the direction of movement relative to a ground position. Also referred to as “ground track.”

Trip Odometer—a running tally of distance travelled since the last reset. See also “Odometer.”

Total Average Speed—average speed of unit for both moving and stopped speeds since last timer reset.

Total Trip Timer—total time the unit has been in operation since last reset of the trip timers.

Turn—the angle difference between the bearing to your destination and your current track. **L** indicates you should turn left; **R** indicates you should turn right.

VMG (Velocity Made Good)—the speed you are closing in on a destination along a course. Also referred to as the vector velocity to your destination.

Voltage—current voltage reading being received by unit.

Water Speed—the speed through the water. This field is only active if the GPSMAP 392/398/492/498 is receiving speed readings from a transducer or NMEA device.

Water Temp—the water temperature. This field is only active if the GPSMAP 392/398/492/498 is receiving speed readings from a transducer or NMEA device.

Waypoint Destination—the final waypoint in the route, or the destination waypoint.

Waypoint Next—the next waypoint in the route.

Messages and Alarms

The GPSMAP 392/398/492/498 uses an on-screen message system to notify you of events and alert you to problems. Press **QUIT** to acknowledge a message or alarm.

Accuracy Alarm—the GPS accuracy has fallen outside of user-set value.

Alarm Clock—the alarm clock has sounded.

Anchor Drag Alarm—you have drifted out of the specified distance range.

Antenna Input is Shorted—some part of the antenna wiring is contacting the chassis.

Approaching [Waypoint Name]—you are a specified alarm distance from a destination waypoint.

Arriving At [Waypoint Name]—you arrived at the destination waypoint.

Battery Alarm—battery voltage has fallen below the value entered in the Battery Alarm setup.

Can't Read User Card—error reading card; remove and reinsert. Contact your dealer or Garmin Product Support if the problem persists.

Can't Read Voltages That High, Limited To Top Of Range—the voltage value in the Battery Alarm setup is higher than the unit can read.

Can't Read Voltages That Low, Limited To Bottom Of Range—voltage value in the Battery Alarm setup is lower than the voltage where the unit automatically turns off.

Can't Unlock Maps—data on data card is not unlocked for the unit. Contact your dealer or Garmin Product Support.

Can't Write User Card, Data Card May Be Full—error reading card; remove and reinsert. Contact your dealer or Garmin Product Support if the problem persists.

Can't Write User Card, Data Card Is Read-Only—the data card in your unit contains data copy protection.

Database Error—internal problem with the unit. Contact your dealer or Garmin Product Support to have the unit serviced.

Deep Water Alarm—the water is deeper than the amount set in the Deep Water Alarm.

Directory Item With This MMSI Already Exists—the MMSI number is already in DSC directory. Use a different number.

Directory Memory is Full, Can't Create Entry—the DSC directory has reached maximum of 100 contacts. Delete unneeded contacts to add new ones.

Distress Call—a DSC distress call has been received. Take appropriate action.

Drift Alarm—the depth has changed by the amount of the Drift Alarm value.

Fish Alarm (not a textual alarm, as indicated by a fish bitmap flashing in the upper left part of the display)—shows an icon and a beep sounds (if enabled) when a fish is detected. This alarm does not show a message banner.

Invalid MMSI—enter a Valid MMSI.

Lost Satellite Reception—the unit has lost satellite signals. Check antenna connections or try moving to a location with a clear view of the sky.

MDB Waypoint Memory is Full, Can't Create Waypoint—unit memory is full; no further data can be saved.

Proximity Alarm—you are nearing a proximity waypoint.

NMEA Depth Is Below Transducer—you must enter an appropriate Keel Offset for the transducer.

No Tide Stations for that Area—no tide stations within 100 miles of the area.

No Proximity Waypoints/Routes/Tracks/User Waypoints Found—attempted to transfer user data from a data card that does not contain the specified type of data. Make sure there is data to transfer on data card.

Off Course Alarm—you are off course the distance set in the “Off Course” alarm.

Proximity Alarm—you entered the alarm radius for the proximity waypoint indicated.

Proximity Alarm Memory Full—you used all available proximity waypoints.

Proximity Overlaps Another Proximity Waypoint—the alarm radius specified overlaps the area specified for another proximity waypoint. Adjust the distance.

Route Already Exists—you entered a route name that already exists in memory. Modify the route name or delete the previous route name.

Route Full—you attempted to add more than 300 points to a route. Reduce the number of points or create a second route.

Route Truncated—uploaded route from another device has more than 300 waypoints and was truncated to fit.

Route Waypoint Memory Full—no additional route waypoints can be saved.

Shallow Water Alarm—the Shallow Water Alarm depth has been reached.

Simulating Operation—the unit is in Simulator Mode. Do not use for normal navigation.

Sonar Failed, Unit Needs Repair—there is an internal problem with the unit. Contact your dealer or Garmin Product Support to have the unit serviced.

Sonar Service Incompatible—(only applied to the GPSMAP 392/492) the external sonar device you are connected to needs a software update.

Sonar Service Lost—(only applied to the GPSMAP 392/492) the external sonar device you were connected to has either been disconnected or the GPSMAP 392/492 has lost communication with the sonar device for some other reason.

Track Already Exists [Track Name]—you entered a saved track name that already exists in memory. Modify the track name or delete the existing track.

Track Memory Full—no more track data can be stored without deleting old data.

Track Log Full—the track log is full and track recording has been turned off. To record more track points, you need to clear the track log and turn track recording on. This only appears when the track recording setting is set to “Stop When Full.”

Track Memory is Full, Can’t Create Track—the track log memory is full. No additional track log data can be stored without deleting old data to create memory space.

Track Truncated—a complete uploaded track does not fit into memory. The oldest track log points were deleted to make space for the most recent data.

Transducer Disconnected, Sonar Turned Off—there is not a transducer attached, bad cable/transducer, or the transducer cable was disconnected. If the transducer cable is removed while the unit is on, reconnect and cycle power.

Transfer Complete—the unit has finished uploading or downloading information to the connected device.

User Card Not Found, Please Insert Card—attempted to transfer user data without a data card containing user data being present in the Data Card slot.

Water Temperature Alarm—sonar has reported a temperature above, below, inside, or outside the specified value(s).

Waypoint Already Exists—you entered a waypoint name that already exists in memory. Modify the waypoint name or delete the existing waypoint.

Waypoint Memory Full—you have used all 4,000 waypoints available. Delete unwanted waypoints to make space for new entries.

LORAN TD System

LORAN-C is a radio navigation aid operated and maintained in the United States by the United States Coast Guard. The name LORAN is an acronym for “LOng RAnge Navigation.” The LORAN system covers the entire United States and the U.S. Coastal Confluence Zone. From the perspective of a mariner, the system is used for ocean and coastal navigation. It can be used as a supplemental system for harbor and harbor approach navigation, and it is used for inland navigation by recreational vehicles.



Change to Loran TD from the Units tab on the Main Menu.

LORAN TD Feature

The LORAN TD (Time Delay) feature eases the transition from using LORAN to using GPS. The GPSMAP unit automatically converts GPS coordinates to LORAN TDs for those who have a collection of LORAN fixes for favorite fishing spots and other waypoints recorded as TDs. You can show your position as a TD or enter waypoints as TDs. The accuracy to be expected from this conversion is approximately 30 meters. When the unit is placed in the LORAN TD format mode, it simulates the operation of a LORAN receiver. Position coordinates can show as TDs, and all navigation functions can be used as if the unit was actually receiving LORAN signals.

Using the LORAN TD Format

When creating new waypoints using LORAN TD coordinates, you must set the correct LORAN chain number and secondary stations in the Setup TD field before storing the waypoint. After the waypoint is stored in unit memory, it always references the LORAN chain number and secondary stations currently selected in the Setup TD field. If you enter a different LORAN chain number or change the secondary stations or offsets in the Setup TD field, the active waypoint information reflects those changes. Since the GPSMAP 392/398/492/498 does not rely on the LORAN signal for navigation, it can reference a different GRI chain and/or secondary stations and still navigate to the location stored in memory.

The LORAN Position Format field is located under the Setup–Location tab in the Main Menu. The **LORAN TD Setup** window contains the fields to select the Loran GRI-Chain Number, Primary and Secondary Stations, and TD Offsets.

Loran TD Setup	
Loran Chain Number	
GRI_8970	
TD Station 1	TD Offset 1
W	0.0
TD Station 2	TD Offset 2
Y	0.0

Loran TD Setup Page

To set up Loran TD from the Main Menu:

1. Press and hold **ADJ/MENU** to show the Main Menu.
2. Using the **ROCKER**, highlight the **Position Format** field on the **Units** tab, and press **ENTER**.
3. Highlight **Loran TD**, and press **ENTER**.
4. Highlight **Setup**, and press **ENTER**.
5. To change the settings of any of the five fields, highlight the field, press **ENTER**, select or enter a setting, then press **ENTER**.
6. When finished, highlight **Save**, and press **ENTER**.

If the active GRI Chain, secondary stations, or offsets have been changed since the waypoint was created, the waypoint now references the active GRI-chain and secondary stations. You must adjust the TD coordinates accordingly. Remember that the GPS is not relying on the LORAN signal for navigation and actually converts the TD coordinate to a useful LAT/LON coordinate before storing the waypoint to memory or using it for navigation. Because of this, the unit can navigate to a TD coordinate anywhere in the world.

You must know your GRI chain number and secondary stations to create a LORAN TD position. For more information, read our LORAN TD Position Format Handbook, available at the Garmin Web site (www.garmin.com/manuals/LoranTDPositionHandbook_Manual.pdf.)

Optional Accessories

The following optional accessories are designed to enhance the operation of the GPSMAP 392/398/492/498.

To obtain replacement parts and optional accessories, contact your Garmin Dealer, Garmin Product Support in the U.S.A. at 800-800-1020, or Garmin Europe at 44-0870-8501241.



WARNING: Garmin accessories have been designed and specifically tested for use with Garmin products. Accessories offered by other manufacturers have not been tested or approved for use with Garmin products. Use of such accessories could cause damage to the GPSMAP 392/398/492/498 and void the warranty.

MapSource Software CD-ROMs—enhances the basemap, create waypoints and routes from your PC. MapSource offers several detailed mapping options that are compatible with the GPSMAP 392/398/492/498, including MetroGuide, BlueChart, and Fishing Hot Spots.

BlueChart g2 Preprogrammed Data Cards—enhances the basemap featuring additional data like highly detailed coastal roads and points of interest such as restaurants, lodging, local attractions and more. Full-color aerial photos of ports, marinas, bridges, and navigational landmarks are also included on many data cards.

Programmable Data Cards—blank data cards are available in 16 MB, 32 MB, 64 MB, 128 MB, and 256 MB sizes. Download street-level map detail, points of interest, business addresses and phone numbers, marine data, topographical information, and more from MapSource CD-ROMs to a data card, either directly through your GPSMAP 392/398/492/498 using the PC Interface Cable, or with the Data Card Programmer.

USB Data Card Programmer—programs blank data cards at high speed through a PC.

Pre-Programmed Data Cards—data cards pre-programmed with either Garmin BlueChart or Fishing Hot Spots map data.

A/C Adapter—powers the unit using a standard AC house current.

PC Interface Cable with Vehicle Power Adapter—connects the GPSMAP 392/398/492/498 to a vehicle's electrical system on one end, and a PC, beacon receiver, marine autopilot, or other compatible device on the other end.

Quick-Release Flush Mount Kit—mounts your Fishfinder flush on the bulkhead or cabin wall. Press the side clips to release the Fishfinder so you can take it with you.

CANet™ Connection Kit—allows you to connect your unit to another CANet-compatible Garmin unit, so you can read sonar displays on chartplotters located elsewhere in the boat.

Software License Agreement

BY USING THE GPSMAP 392/398/492/498, YOU AGREE TO BE BOUND BY THE TERMS AND CONDITIONS OF THE FOLLOWING SOFTWARE LICENSE AGREEMENT. PLEASE READ THIS AGREEMENT CAREFULLY.

Garmin grants you a limited license to use the software embedded in this device (the “Software”) in binary executable form in the normal operation of the product. Title, ownership rights, and intellectual property rights in and to the Software remain in Garmin.

You acknowledge that the Software is the property of Garmin and is protected under the United States of America copyright laws and international copyright treaties. You further acknowledge that the structure, organization, and code of the Software are valuable trade secrets of Garmin and that the Software in source code form remains a valuable trade secret of Garmin. You agree not to decompile, disassemble, modify, reverse assemble, reverse engineer, or reduce to human readable form the Software or any part thereof or create any derivative works based on the Software. You agree not to export or re-export the Software to any country in violation of the export control laws of the United States of America.

Product Registration

Help us better support you by completing our online registration today! Connect to our Web site at www.garmin.com/registration/.

Use this area to record the serial number (8-digit number located on the back of the GPSMAP 392/398/492/498) in case your GPSMAP 392/398/492/498 needs service. Keep the original sales receipt, or a photocopy, in a safe place.

Serial Number: _____

Contact Garmin

Contact Garmin if you have any questions while using your GPSMAP 392/398/492/498. In the USA contact Garmin Product Support by phone: 913/397.8200 or 800/800.1020, Monday–Friday, 8 AM–5 PM Central Time; or go to www.garmin.com/support/, and click **Product Support**.

In Europe, contact Garmin (Europe) Ltd. at 44/0870.8501241.

Limited Warranty

This Garmin product is warranted to be free from defects in materials or workmanship for one year from the date of purchase. Within this period, Garmin will at its sole option repair or replace any components that fail in normal use. Such repairs or replacement will be made at no charge to the customer for parts or labor, provided that the customer shall be responsible for any transportation cost. This warranty does not cover failures due to abuse, misuse, accident or unauthorized alteration or repairs.

THE WARRANTIES AND REMEDIES CONTAINED HEREIN ARE EXCLUSIVE AND RANGE Down LIEU OF ALL OTHER WARRANTIES EXPRESS OR IMPLIED OR STATUTORY, INCLUDING ANY LIABILITY ARISING UNDER ANY WARRANTY OF MERCHANTABILITY OR FITNESS FOR A PARTICULAR PURPOSE, STATUTORY OR OTHERWISE. THIS WARRANTY GIVES YOU SPECIFIC LEGAL RIGHTS, WHICH MAY VARY FROM STATE TO STATE.

RANGE Down NO EVENT SHALL GARMIN BE LIABLE FOR ANY INCIDENTAL, SPECIAL, INDIRECT OR CONSEQUENTIAL DAMAGES, WHETHER RESULTING FROM THE USE, MISUSE, OR INABILITY TO USE THIS PRODUCT OR FROM DEFECTS RANGE Down THE PRODUCT. Some states do not allow the exclusion of incidental or consequential damages, so the above limitations may not apply to you.

Garmin retains the exclusive right to repair or replace the unit or software or offer a full refund of the purchase price at its sole discretion. SUCH REMEDY SHALL BE YOUR SOLE AND EXCLUSIVE REMEDY FOR ANY BREACH OF WARRANTY.

To obtain warranty service, contact your local Garmin authorized dealer or call Garmin Product Support for shipping instructions and an RMA tracking number. The unit should be securely packed with the tracking number clearly written on

the outside of the package. The unit should then be sent, freight charges prepaid, to any Garmin warranty service station. A copy of the original sales receipt is required as the proof of purchase for warranty repairs.

Garmin International, Inc.
1200 E 151st Street, Olathe, Kansas 66062 USA
Tel. 913/397.8200
Fax. 913/397.8282

Garmin (Europe) Ltd.
Unit 5, The Quadrangle, Abbey Park Industrial Estate, Romsey, SO51 9DL UK
Tel. 44/0870.8501241
Fax 44/0870.8501251

Online Auction Purchases: Products sold through online auctions are not eligible for rebates or other special offers from Garmin. Online auction confirmations are not accepted for warranty verification. To obtain warranty service, an original or copy of the sales receipt from the original retailer is required. Garmin will not replace missing components from any package purchased through an online auction.

International Purchases: A separate warranty is provided by international distributors for units purchased outside the United States. This warranty is provided by the local in-country distributor and this distributor provides local service for your unit. Distributor warranties are only valid in the area of intended distribution. Units purchased in the United States or Canada must be returned to the Garmin service center in the United Kingdom, the United States, Canada, or Taiwan for service.

The Garmin GPSMAP 392/398/492/498 has no user-serviceable parts. Should you ever encounter a problem with your unit, please take it to an authorized Garmin dealer for repairs.

FCC Compliance

The GPSMAP 392/398/492/498 complies with Part 15 of the FCC interference limits for Class B digital devices FOR HOME OR OFFICE USE. These limits are designed to provide more reasonable protection against harmful interference in a residential installation, and are more stringent than “outdoor” requirements.

Operation of this device is subject to the following conditions: (1) This device may not cause harmful interference, and (2) this device must accept any interference received, including interference that may cause undesired operation.

This equipment generates, uses, and can radiate radio frequency energy and may cause harmful interference to radio communications if not installed and used in accordance with the instructions. However, there is no guarantee that interference will not occur in a particular installation.

If this equipment does cause harmful interference to radio or television reception, which can be determined by turning the equipment off and on, the user is encouraged to try to correct the interference by one of the following measures:

- Reorient or relocate the receiving antenna.
- Increase the separation between the equipment and the receiver.
- Connect the equipment into an outlet on a circuit different from that to which the receiver is connected.

- Consult the dealer or an experienced radio/TV technician for help.

The GPSMAP 392/398/492/498 does not contain any user-serviceable parts. Repairs should only be made by an authorized Garmin service center. Unauthorized repairs or modifications could result in permanent damage to the equipment, and void your warranty and your authority to operate this device under Part 15 regulations.

Industry Canada Compliance

This Category II radiocommunication device complies with Industry Canada Standard RSS-310.

Conformité à la réglementation de la Industry Canada

Ce dispositif de radiocommunication de catégorie II rencontre la norme CNR-310 d'Industry Canada.

Declaration of Conformity (DoC)

Hereby, Garmin, declares that this GPSMAP 392/398/492/498 is in compliance with the essential requirements and other relevant provisions of Directive 1999/5/EC.

To view the full Declaration of Conformity, see the Garmin Web site for your Garmin product: <http://www.garmin.com/products/gpsmap498/>. Click **Manuals**, and then select the **Declaration of Conformity** link.

INDEX

Symbols

200 kHz frequency 72
 2X zoom 77
 4X zoom 77
 50 kHz frequency 72

A

a-scope 77
 accessories 105
 accuracy 37
 accuracy circle 62
 active route page 36
 options 36
 additional information 21
 advanced map card 63
 alarms
 anchor drag 70
 arrival 71
 battery 70
 clock 70
 DSC 25
 fish 71
 off course 71
 shallow/deep water 71
 temperature 71
 alarm tab 70
 anchor drag alarm 70

arches 74
 arrival alarm 71
 automatic scroll speed 80
 auto color gain 80

B

backlight 4
 basemap 63
 battery alarm 70
 bearing line 62
 bottom of the water 73
 btm (bottom) lock 77

C

calibrate water speed 80, 81
 card tab 59
 caution i
 celestial tab 45
 chart 62
 cleaning vi
 clock alarm 70
 clutter 74
 color 73
 color bar 77
 communication tab 68
 compass page 32
 conventions i
 course line 62
 course up 62

D

data cards 94
 data entry 6
 date/time 95
 daylight saving time 68
 delete
 DSC directory item 23
 depth line 76
 dilution of precision 98
 distance 58
 distress calls 22, 22–24
 DOP 98
 DSC 21
 call list 23
 directory 23
 log 23
 setting up 25
 DSC tab 59

E

edit
 waypoint 11
 Enter/Mark key 5, 8

F

FCC compliance 108
 find 19
 Find key 5, 19
 fish alarm 71
 fish symbols 74, 81

flasher page 84
 frequency
 200 kHz 72
 50 kHz 72

G

gain 75
 gain setting 74
 garmin data transfer 68
 go to 13
 distress call 24
 position report 24
 GPS tab 37
 options 39

H

hard bottom 84
 heading line 62
 Highway Page, 3D 33
 options 35
 highway tab 64

I

initializing 1
 installation 87
 interface keys 5
 interfacing 93
 In Zoom key 5

K

keel offset 79
keypad usage 5
key beeps 65

L

language 65
license agreement 106
LORAN TD 103

M

magnetic variation 67
main menu 37
main pages 26
Man OverBoard 10
MapSource 59
map datum 66
Map Page 27
 options 30
 setup map 32
map pointer 7, 28
map scales 29
map tab 61
Maritime Mobile Service Identity 97
Mark key 5
measure distance 31
Menu key 5
merge from card 59
messages 100

MMSI 22, 97
MOB 10

N

narrow beam 72
NAV/MOB Key 5, 12
navaids 63
navigating 12
 distress call 24
 Go To 13
 position report 24
 routes 18
 TracBack 14
navigation terms 98
NMEA 70
north up 62

O

off course alarm 71
orientation 62
Out Zoom key 5
overzoom 29

P

pages tab 61
Page key 5
points tab 46
position format 66
position reports 22

Power key 5
power on/off 1
proximity waypoints 50

Q

Quit key 5

R

receiving a DSC call 24
replace from card 59
review
 DSC call 23
 waypoints 11
Rocker key 5
routes 17
 copy 51
 create 17
 delete 51
 delete all 51
routes tab 51
route review page 52
 options 53

S

satellite location 95
satellite sky view 95
scroll speed 80
selecting options 6
shallow/deep water alarm 71

simulator mode 3
software update card 65
soft bottom 84
sonar 72
 depth line 76
 understanding 72
 whiteline 76
Sonar Page 74
 adjustment menu 75
sonar tab 64
 options 79
sound waves 72
specifications 86
speed filter 65
split when zoomed 77
storage vi
strongest sonar returns 73
surface clutter 74
swap split 77
system information 65
system tab 65

T

temperature 82
temperature graph 77
temperature scale 64
temperature tab 63
thermoclines 83

tide tab 40
time format 68
time tab 68
time zone 68
tools 77
TracBack 14
 activate 16
track logs
 clear 15
 save 15
track tab 57
 active 57
 saved 57
track up 62
transducer 82, 90
transducer type 80
trip planning 56
trip tab 44

U

underwater waypoints 78
units tab 66

V

view 77

W

WAAS 96
 disable/enable 39
warning i
waterproof vi
water speed 80, 82
water temperature alarm 71
waypoints
 creating 8
 creating graphically 9
 editing 11
 Enter/Mark 8
 move 12
 proximity 50
 reviewing 11
 underwater 78
waypoint lists
 proximity 49
 user 47
weakest returns 73
whiteline 76, 83
wide beam 72
wiring installation 92

Z

zoom 77
Zoom keys 5
zoom settings 29

**For the latest free software updates (excluding map data) throughout the life of your
Garmin products, visit the Garmin Web site at www.garmin.com.**



© Copyright 2006 Garmin Ltd. or its subsidiaries

Garmin International, Inc.
1200 East 151st Street, Olathe, Kansas 66062, USA

Garmin (Europe) Ltd.
Unit 5, The Quadrangle, Abbey Park Industrial Estate, Romsey, SO51 9DL, UK

Garmin Corporation
No. 68, Jangshu 2nd Road, Shijr, Taipei County, Taiwan

www.garmin.com

Part Number 190-00653-00 Rev. C