



## Fishfinder 300C Installation Instructions

Compare the contents of this package with the packing list on the box. If any pieces are missing, contact your Garmin dealer immediately. Before you begin the installation:

- Read and follow the instructions to install the Fishfinder 300C.
- Gather the appropriate fasteners and tools.
- Verify that all cables can reach the Fishfinder 300C mounting location and the transducer.
- Wear safety goggles and a dust mask when drilling, cutting, or sanding.

**If you experience difficulty installing the Fishfinder 300C, contact Garmin Product Support or contact a professional installer.**

**WARNING:** See the *Important Safety and Product Information* guide in the product box for product warnings and other important information.

### To install and use your Fishfinder 300C:

1. Select a location.
2. Mount the Fishfinder 300C.
3. Install the transducer.
4. Install the wiring harness.
5. Test the installation.

## Step 1: Select a Location for the Fishfinder 300C

Consider the following when you select an installation location:

- Provide optimal viewing as you operate your vessel.
- Allow easy access to the keypad on the Fishfinder 300C.
- Is strong enough to support the weight of the Fishfinder 300C and protect it from excessive vibration or shock.
- Allow room for the routing and connection of the cables. There should be at least a 3-inch (8 cm) clearance behind the case.

DO NOT mount the Fishfinder 300C in an area that is exposed to extreme temperature conditions.

 **NOTE:** The temperature range for the Fishfinder 300C is from 5°F to 131°F (from -15°C to 55°C). Extended exposure to temperatures exceeding this range (in storage or operating conditions) may cause failure of the LCD screen or other components. This type of failure and related consequences are not covered by the manufacturer's limited warranty.

## Step 2: Mount the Fishfinder 300C

You can mount your Fishfinder 300C in one of two ways:

- Bail Mount—mount the Fishfinder 300C onto the bracket that attaches to the console or overhead.
- Flush Mount—use the flush mount kit to mount the Fishfinder 300C into a flat panel.

### Bail Mounting the Fishfinder 300C

The Fishfinder 300C is suitable for mounting in exposed locations or at the navigation station. The included tilt mounting bracket can be used for console or overhead mounting. Bail mounting requires the following tools and hardware:

- Three of the included number 8 (4.2 × 1.4 DIN7981) ANSI mounting screws
- Phillips-head screwdriver (not included)
- Drill and drill bit (not included)
- Center punch and hammer (not included)

Use the following table to determine the drill bit size:

Material	Material Thickness (in.)	Material Thickness (mm)	Hole Size (in.)	Hole Size (mm)	Hole Size (Drill Number)
Aluminum alloy sheet metal	from 1/32 to 5/64	from 0.76 to 2.03	.128	3.25	30
	from 3/32 to 3/8	from 2.28 to 9.52	.147	3.73	26
Fiberglass - all thicknesses			.140	3.56	28
High Density Plastic - all thicknesses			.125	3.17	1/8
Plywood (resin impregnated)—Professional installation recommended			.144	3.66	27

**Drill Size Table**

**To mount the bracket assembly:**

1. Using the base of the bracket as a template, mark the location of the three holes (two screws towards the front, one screw towards the back).
2. Using the center punch, indent the center of each of the three mounting-hole locations.
3. Drill the mounting holes, using the bit size indicated in the Drill Size Table above.
4. Secure the base with the three included screws.

**To install the Fishfinder 300C on the mounting bracket:**

1. Align the slot on the back of the Fishfinder 300C with the mounting knob, and slide the fishfinder into place. If necessary, adjust the knob to spread the bracket arms apart.
2. Adjust the Fishfinder 300C angle and tighten the knob until snug.



**Flush Mounting the Fishfinder 300C**

In addition to four of the included number 8 ANSI (4.2 × 1.4 DIN7981) mounting screws, flush mounting the Fishfinder 300C requires the following tools:

- Phillips-head screwdriver
- Drill and drill bit (refer to Drill Size Table above for drill size) for mounting holes
- 3/8" (10 mm) drill bit for pilot hole
- Jigsaw
- Scissors
- Center punch and hammer
- File and sandpaper
- Anti-seize lubricant (optional)

---

 **NOTE:** Ensure that the surface on which you mount the Fishfinder 300C has sufficient open space behind it to accommodate the Fishfinder 300C and the connected wires.

---

**To flush mount the Fishfinder 300C:**

1. The flush-mount template is included in the product box. Trim the template and ensure it will fit in the location where you want to flush mount the Fishfinder 300C.
2. The flush-mount template has adhesive on the back. Remove the protective liner and apply the template to the location at which you want to mount the Fishfinder 300C.
3. Using the center punch, indent the center of each of the four mounting-hole locations.
4. Using a drill bit as specified by the Drill Size Table, drill the four mounting holes.
5. Using a 3/8" (9 mm or 10 mm) drill bit, drill a pilot hole inside the corner of the template to begin cutting the mounting surface.
6. Using the jigsaw, cut the mounting surface along the inside of the solid line indicated on the flush-mount template. Use a file and sandpaper to refine the size of the hole.
7. Apply the adhesive side of the gasket to the back of the Fishfinder 300C.

8. If the top and bottom mounting covers are attached to the front of the Fishfinder 300C, remove them by unsnapping the covers from the sides.
9. Place the Fishfinder 300C into the cutout.

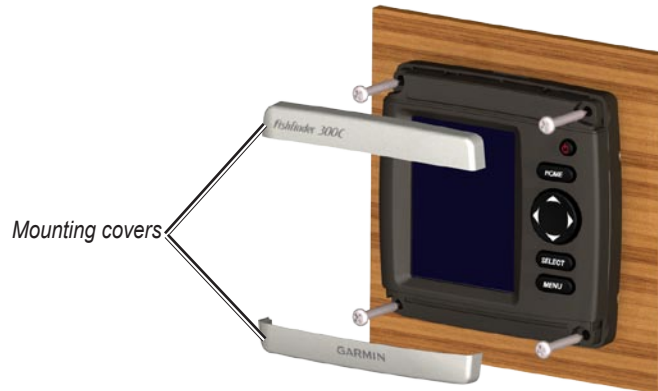

10. Securely tighten the four mounting screws through the Fishfinder 300C into the drilled mounting holes.

**NOTE:** Stainless-steel screws may bind when screwed into fiberglass and overtightened. Garmin recommends applying an anti-galling stainless anti-seize lubricant to the screw before using.

11. Replace the mounting covers by snapping them into place.

### Step 3: Install the Transducer

The following instructions describe the basic installation of typical transducers, such as the one included with your Fishfinder 300C. Additional installation instructions are provided in the transducer kits. Some transducers may have to be installed by a professional marine installer.

**CAUTION:** DO NOT cut the transducer lead or any part of the transducer cable. Cutting the transducer cable voids your warranty. The cable cannot be spliced and connected to any existing (Garmin or non-Garmin) transducer cables.

If the transducer lead is too short, extension cables are available from your Garmin dealer. Coil and secure any excess cable.

### Assembling the Transducer

#### To assemble the transducer:

1. Insert the rubber washer and the plastic spacer into the transducer at the same time. DO NOT lubricate the rubber washer.
2. Route the cable toward the back of the transducer. Slide the transducer into the transducer mount.
3. Place the 5 mm flat washer on the 10-32 × 1.75" screw, and insert the screw through the transducer mount, the spacer, and the rubber washer.
4. Place the remaining 5 mm flat washer on the exposed end. Install the 10-32 locknut finger tight. Retighten the transducer after installation on the boat.

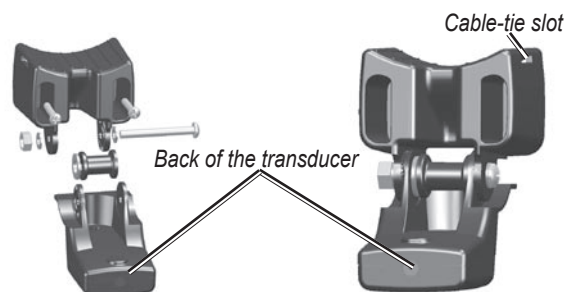

## Mounting the Transducer on a Trolling Motor

### To mount the transducer on a trolling motor:

1. Slide the large cable tie through the slot on the transducer mount, with the ridges of the cable tie facing up, until equal lengths of cable tie extend on both sides of the mount.



---

**NOTE:** For cold water, or heavy timber or debris areas, a metal 4–5" (100–130 mm) worm-gear clamp is recommended.

---

2. Position the mount gasket on the curved top of the transducer mount.
3. Place the transducer assembly against the motor body of the trolling motor, with the front of the transducer pointed away from the trolling-motor propeller.
4. Wrap the two ends of the cable tie around the motor body. Place the pointed end of the cable tie through the fastener hole on the opposite end and pull it through until it is snug but not tight. (The cable tie clicks when you pull it.)
5. Position the transducer so that it is parallel with the bottom when in use, and make sure the gasket is aligned properly. Pull the cable-tie end until tight. Trim off the excess if necessary. Tighten the 10-32 locking nut until it touches the mounting bracket, and then tighten 1/4 turn more. (Do not overtighten.)
6. Route the 30-foot (9 m) transducer cable using the supplied cable ties to secure the cable to the motor shaft. You can fill the forward-facing portion (except the cable-tie pocket) of the transducer mount with sealant to avoid accumulating debris.

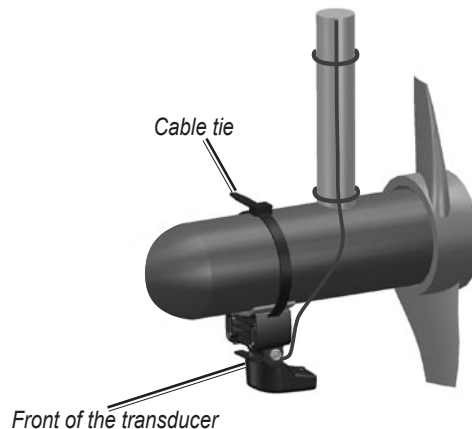

## Mounting the Transducer on a Transom

When selecting a transom-mount location, consider the following for optimal performance:

- For your sonar to operate properly, the transducer must be located in calm water.
- Mount the transducer as close to the center of the boat as possible.
- DO NOT cut the transducer lead. (This voids your warranty.)
- DO NOT mount the transducer in locations where it might be jarred when launching, hauling, or storing.
- DO NOT mount the transducer in the path of the propeller on single-drive boats. The transducer can cause cavitation that can degrade the performance of the boat and damage the propeller. On twin-drive boats, mount the transducer between the drives, if possible.



---

**NOTE:** DO NOT mount the transducer behind strakes, struts, fittings, water intake or discharge ports, or anything that creates air bubbles or causes the water to become turbulent. The transducer must be in clean (non-turbulent) water for optimal performance.

---

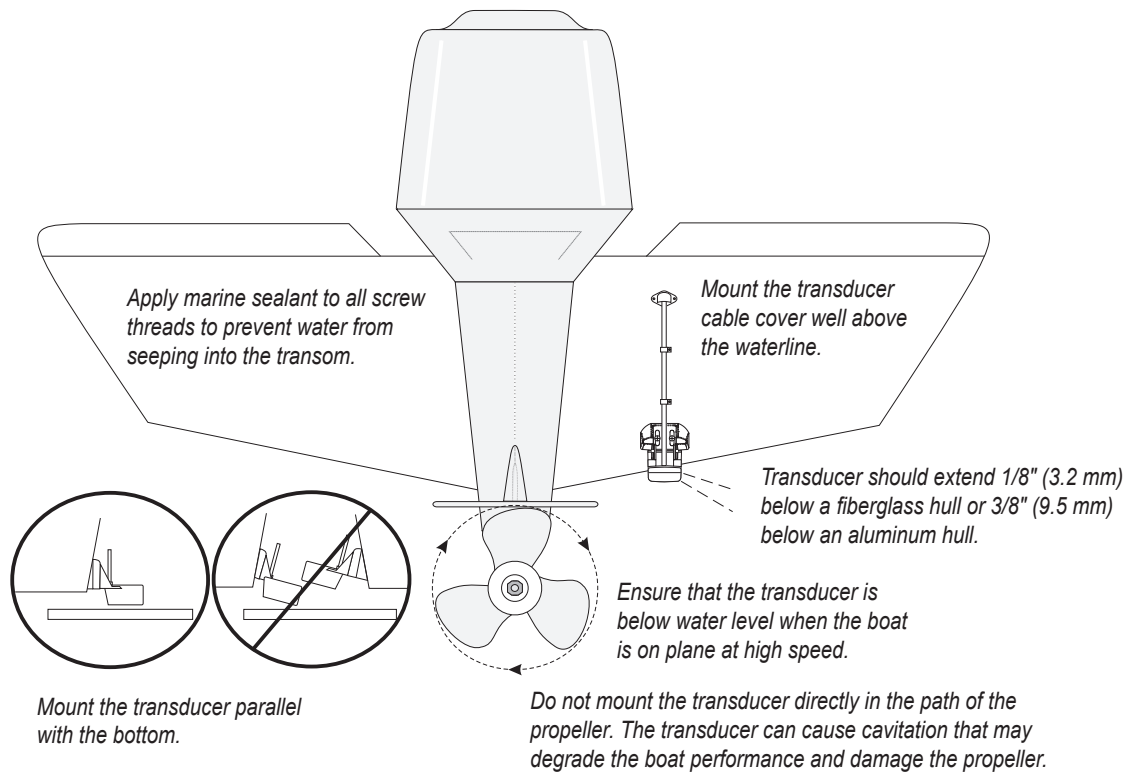

**Required Tools** (not included)—drill, 3/8" wrench or socket, 5/32" (4 mm) and 1/8" (3.2 mm) drill bits, masking tape, number 2 Phillips screwdriver, and marine sealant.

**To mount the transducer on a transom:**

1. Position the transducer mount at the selected transom location. Make sure the transducer is parallel with the water line. Mark the center locations of each hole on the transducer mount.
2. Using a 5/32" (4 mm) bit, drill the pilot holes approximately 1" (25 mm) deep at the marked locations. To avoid drilling the holes too deep, wrap a piece of tape around the bit at 1" (25 mm) from the point of the bit.
3. Apply marine sealant to the 5 × 30 mm screws. Attach the transducer assembly to the transom using the 5 × 30 mm screws. Adjust the transducer assembly to extend beyond the bottom of the transom approximately 1/8" (3 mm) on fiberglass hulls or 3/8" (10 mm) on aluminum hulls. Adjust the transducer assembly to be aligned parallel with the water.
4. Tighten the 10-32 locking nut until it touches the mounting bracket, and then tighten 1/4 turn more. (Do not overtighten.)
5. Place the first cable clamp on the transducer cable, approximately one third of the distance between the transducer and the top of the transom.
6. Mark the location. Using a 1/8" (3.2 mm) bit, drill a pilot hole approximately 3/8" (10 mm) deep.
7. Attach the cable clamp using one of the 4 × 12 mm screws. Coat the screw with marine sealant before installation. Repeat steps 5 and 6 using the other cable clamp.
8. Route the transducer cable to the Fishfinder 300C. Do not cut the cable. Avoid routing the cable close to electrical wires or other sources of electrical interference.

## Step 4: Install the Wiring Harness

The Fishfinder 300C comes with a cable assembly that connects it to power and to the transducer with one connection and provides interface capabilities for connecting external devices.

The color code in the diagram on [page 7](#) indicates the appropriate harness connections. The replacement fuse is an AGC/3AG 3A fuse. If it is necessary to extend the power wires, use 22 AWG wire. Do not cut the transducer cable. Cutting the transducer cable voids your warranty. If your boat has an electrical system, you might be able to wire the Fishfinder 300C directly to an unused holder on your current fuse block. If you are using the fuse block, remove the in-line fuse holder supplied with the Fishfinder 300C. You can also wire the Fishfinder 300C directly to the battery.

**CAUTION:** The Fishfinder 300C maximum input voltage is 33 Vdc. Do not exceed this voltage, because this can damage the Fishfinder 300C and void the warranty.

**NOTE:** During a typical installation, use only the red and black wires. The other wires do not have to be connected for normal operation of the Fishfinder 300C. For information on connecting to a NMEA 0183-compatible device, see [page 7](#).

### To install the wiring harness:

1. Use a test light or voltmeter to determine the polarity of the voltage source.
2. Connect the red (+ or positive) wire to the positive voltage terminal. (If you use the fuse block on the boat, route the positive connection through the fuse, as shown on the diagram.)
3. Connect the black (- or ground) wire to the negative voltage terminal.
4. Install or check the 3A fuse (on the fuse block or in the in-line holder).
5. Align the notches on the cable plug and on the back of the Fishfinder 300C. Insert the cable into the connector, and turn the locking ring counter-clockwise until it stops.

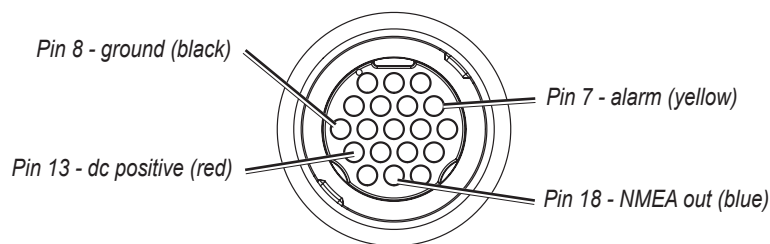
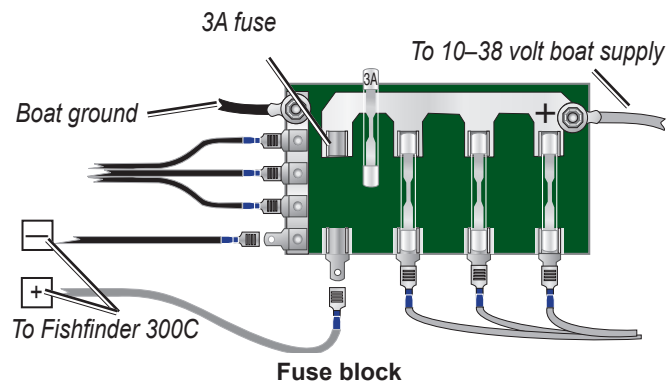

**Fishfinder 300C Power/Data  
Cable Pin Assignment**

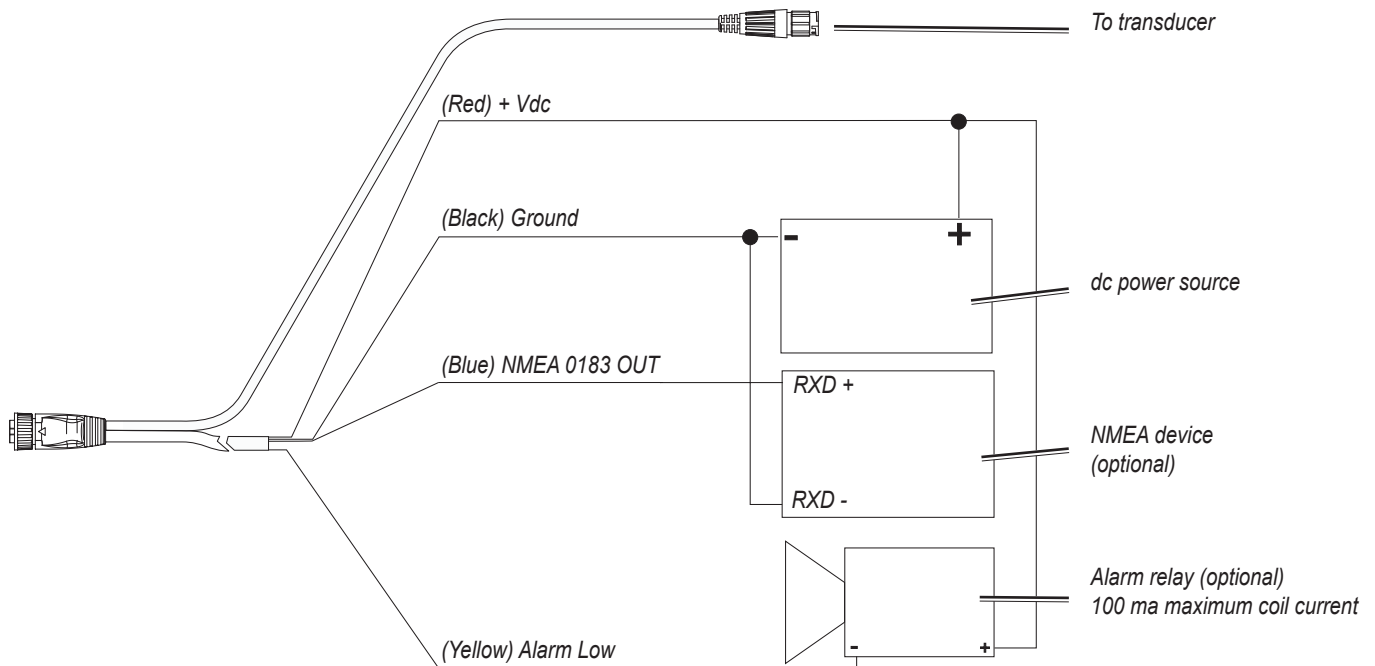

**Fishfinder 300C Wiring Diagram**

## Connecting to a NMEA device

You can connect the Fishfinder 300C to additional NMEA 0183-compatible electronic equipment, such as a Garmin GPS (Global Positioning System) device. If equipped with a capable transducer, the Fishfinder 300C can send depth, temperature, and speed information. Refer to the Fishfinder 300C wiring diagram for connecting the Fishfinder 300C to NMEA 0183-compatible devices.

### To install the wiring harness to a GPS or other NMEA 0183 device:

1. Follow the instructions in **Step 4: Install the Wiring Harness** on [page 6](#). For Garmin units, the ground (black) wires serve as NMEA ground and must be attached together or on the same terminal. Refer to the wiring diagram of your GPS or NMEA 0183 device for wire identification.
2. Connect the blue (NMEA 0183-OUT) wire from the Fishfinder 300C to the NMEA 0183-IN wire on the wiring harness of the other NMEA 0183 device.
3. Turn on the Fishfinder 300C **NMEA Output** setting. (From the Home screen, select **Configure > System > NMEA Output > On.**)
4. Configure the other NMEA 0183 device according to the manufacturer's instructions.

## Interfacing with NMEA

The Fishfinder 300C allows for NMEA 0183 Version 3.01 output with a compatible GPS or navigation device. You must set NMEA Output to On to send data.

The Fishfinder 300C sends the SDDBT, SDDPT, SDMTW, SDVHW, SDWPL sentences in NMEA 0183 Version 3.01 output.

## Step 5: Test the Installation

 **NOTE:** Although it is possible to perform some checks with the boat on a trailer, the boat should be in the water to properly test the installation.

Press and hold the  **POWER** key until the Fishfinder 300C beeps. Use **ROCKER** and **SELECT** to highlight and select menu items on the Fishfinder 300C.

The first time you turn your Fishfinder 300C on, you must configure a series of initial settings.

### To initialize your Fishfinder 300C settings:

1. **Language**—select the on-screen language.
2. **Units**—select **Statute (mh, ft, °F)**, **Metric (kh, m, °C)**, or **Nautical (kt, ft, °F)**.
3. **Color Scheme**—select **White** or **Blue** as the background on sonar screens.
4. Select **OK** to return to the Home screen.

The Home screen appears after you select your configuration options.

 **NOTE:** If the transducer is not detected, a “Transducer Disconnected, Sonar Turned Off” message appears.

The transducer must be in the water to work properly. You cannot get a depth or distance reading when the transducer is out of the water.

When you place your boat in the water, check for leaks around any screw holes that were added below the water line. Do not leave your boat in the water for an extended period of time without checking for leaks.

### To test the transom-mount transducer installation:

1. Begin testing the installation at a slow speed. If the sonar appears to be working properly, gradually increase boat speed while observing sonar operation. If the sonar signal is suddenly lost, or the bottom return is severely degraded, note the speed at which this occurs.
2. Return the boat to the speed at which the signal was lost. Make moderate turns in both directions to see if the signal improves.
3. If the signal strength improves while turning, adjust the transducer so that it extends another 1/8" (3 mm) below the transom of the boat. It might take several adjustments to eliminate the degradation.
4. If the signal does not improve, you might have to move the transducer to a different location.

 **NOTE:** When adjusting the depth of the transducer, make the adjustments in small increments. Placing the transducer too deep can adversely affect boat performance and put the transducer at greater risk of striking underwater objects.

**For the latest free software updates (excluding map data) throughout the life of your Garmin products, visit the Garmin Web site at [www.garmin.com](http://www.garmin.com).**



© 2007 Garmin Ltd. or its subsidiaries

Garmin International, Inc.  
1200 East 151st Street, Olathe, Kansas 66062, USA

Garmin (Europe) Ltd.  
Liberty House, Hounslow Business Park, Southampton, Hampshire, SO40 9RB UK

Garmin Corporation  
No. 68, Jangshu 2nd Road, Shijr, Taipei County, Taiwan

[www.garmin.com](http://www.garmin.com)

Part Number 190-00864-03 Rev. B