



GMR 18/24 GMR 18 HD/24 HD

Radome

Installation Instructions



All rights reserved. Except as expressly provided herein, no part of this manual may be reproduced, copied, transmitted, disseminated, downloaded or stored in any storage medium, for any purpose without the express prior written consent of Garmin. Garmin hereby grants permission to download a single copy of this manual onto a hard drive or other electronic storage medium to be viewed and to print one copy of this manual or of any revision hereto, provided that such electronic or printed copy of this manual must contain the complete text of this copyright notice and provided further that any unauthorized commercial distribution of this manual or any revision hereto is strictly prohibited.

Information in this document is subject to change without notice. Garmin reserves the right to change or improve its products and to make changes in the content without obligation to notify any person or organization of such changes or improvements. Visit the Garmin Web site (www.garmin.com) for current updates and supplemental information concerning the use and operation of this and other Garmin products.

Raymarine® is a registered trademark of Raymarine Ltd. Garmin® is a trademark of Garmin Ltd. or its subsidiaries, registered in the USA and other countries. This trademark may not be used without the express permission of Garmin.



Introduction

Thank you for choosing a Garmin radome. This radome utilizes the performance of Garmin radar and provides overlay and color information when combined with a Garmin marine network chartplotter.

Product Registration

Help us better support you by completing our online registration today! Connect to our Web site at <http://my.garmin.com>. Keep the original sales receipt, or a photocopy, in a safe place.

Contact Garmin

Contact Garmin if you have any questions while using your Garmin radome. In the USA contact Garmin Product Support by phone: (913) 397-8200 or (800) 800-1020 or go to www.garmin.com/support/.

In Europe, contact Garmin (Europe) Ltd. at +44 (0) 870.8501241 (outside the UK) or 0808 2380000 (within the UK).

 **NOTE:** The Garmin radome has no user-serviceable parts. If you encounter a problem with your unit, please take it to an authorized Garmin NMEA dealer or contact Garmin Product Support for repairs.

Packing List

Before installing and getting started with your unit, check that your package includes the following items. **If any parts are missing, please contact your Garmin dealer immediately.**

Standard Package:

- GMR 18/24 radome or GMR 18 HD/24 HD radome
- Power cable
- Marine network cable
- Field install RJ-45 network cable connector
- Mounting kit hardware
- Packet of anti-seize compound
- Mounting template
- Grommet for marine cable

Installation

Radome Installation

The following section covers the installation and setup of the Garmin radome. The Garmin radome only operates with Garmin chartplotters through a Garmin marine network. See your Garmin dealer or the Garmin Web site for more details.

To complete the installation, you need the appropriate fasteners, tools, and mounts. These items should be available at most marine dealers. Always wear safety goggles, ear protection, and a dust mask when drilling, cutting, or sanding. When drilling or cutting, always check first to see what is on the other side of the surface. If you experience difficulty with the installation, contact Garmin Product Support or seek the assistance of a professional installer.

Installation Guidelines

To maximize the performance of the radar, observe the following installation guidelines:

- An ideal radome mounting location is high above the ship's keel line with a minimal part of the vessel's structure or rigging blocking the radar beam. Obstructions in the path of the radar beam may cause blind and shadow sectors, or generate false echoes. The higher the installation position, the further the radome can detect targets.
- Avoid mounting the radome on the same level as smoke stacks, horizontal spreaders, or crosstrees on a mast. Do not install the radome near heat sources where it may be subjected to smoke or hot air from smoke stacks or heat from lights.
- The mounting surface or platform should be sturdy enough to support the weight of the radome (GMR 18/18 HD = 7.17 kg/15.8 lbs, GMR 24/24 HD = 9.12 kg /20.1 lbs), as flat as possible, and parallel with the vessel's water line.
- It is recommended that the radar radome be mounted out of range of personnel (horizontal beam width above head height). When the radome is transmitting, do not look directly at the antenna at close range; eyes are the most sensitive part of the body to electromagnetic energy. When properly installed and operated, the use of this radar conforms to the requirements of ANSI/IEEE C95.1-1992 Standard for Safety Levels with Respect to Human Exposure to Radio Frequency Electromagnetic Fields.
- A "Compass Safe Distance" must be maintained between a compass and the radome. The Compass Safe Distance is measured from the center point of the compass to the nearest point on the radome.
- Standard compass = 1 m (39 3/8")
- Standby Steering and Emergency compasses = 0.5 m (19 3/4")

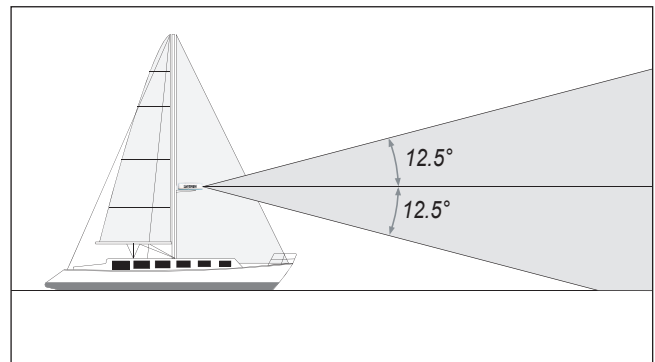
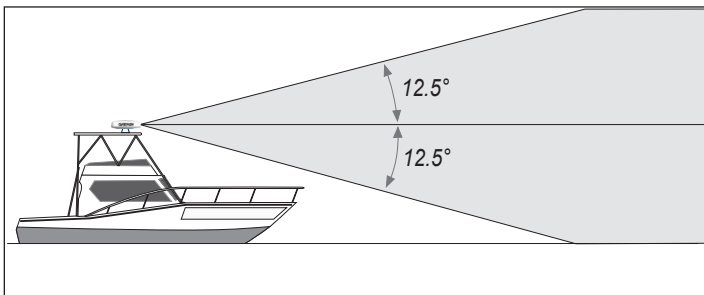

- Mount other electronics and cables more than 2 m (78 3/4") from the path of a radar beam. A radar beam can normally be assumed to spread 25° vertically above and below the radome's radiating element. For vessels with higher bow angles at cruise speed, it may be helpful to lower the angle so the beam points slightly downward to the waterline while at rest. Shims may be used as necessary.
- Install the radome away from antennas or other electronics. GPS antennas should be either above or below the radar beam path of the radome. Mount at least 1 m (39 3/8") from any equipment transmitting or cables carrying radio signals, such as VHF radios, cables, and antennas. In the case of Single Side Band SSB radios, the distance should be increased to 2 m (78 3/4"). IEC 60936-1, clause 3-27.1, states maximum distances from the antenna at which RF (radio frequency) levels can be expected.
(100W/m squared = 121.92 cm [48"]) (10W/m squared = 274.32 cm [108"])
- The radar radome transmits electromagnetic energy. It is important that the radar is turned off or the DC power input is disconnected when personnel are required to come close to the radome to perform work on the radome assembly or associated equipment.

Installation Procedures

The following order of mounting the radome and attaching the power and network cables may vary depending on the installation location and mount used.

Mounting the Radome

1. When a suitable mounting location is determined, verify that the mounting hole locations are aligned fore and aft, and use the included mounting template or reference Figure 1 to drill four 9.5 mm ($\frac{3}{8}$ ") mounting holes. (This step is not necessary if you are using a pre-drilled Garmin compatible or Raymarine® mount.)
2. Align the notch and locking ring on the power cable to the power connector. Press the 2-pin power cable to the power connector and the RJ-45 marine network cable to the RJ-45 socket (Figure 2). Turn the power cable locking ring clockwise until it stops. Tighten the RJ-45 locking ring clockwise until it is firmly sealed.
3. The power and network cables may be pressed into any of the five guide grooves molded into the bottom of the radome case and secured under the cable hold-down plate (Figure 2). Avoid excessive bending or twisting of the cables. See the following "Cable Runs" section for more information.
4. Position the radome on the mounting surface with the triangular mark on the case aligned to the front of the vessel. Apply a bead of marine sealant around each of the mounting holes on the mounting surface.
5. Apply the included anti-seize compound to the threads of the four M8 x 1.25 x 60 threaded rods.
6. Install the four (4) M8 x 1.25 x 60 threaded rods into the mounting holes on the bottom of the radome. There should be no more than 50 mm \pm 1mm (2") extruding from the radome when they are installed properly.
7. Fasten the radome to the mounting surface using the M8 x 1.25 x 60 threaded rods (installed in the previous step), spring washers, flat washers, and M8 Hex nuts as shown in Figure 3. **The nuts should be torqued to between 13.7-18.6 N m (10-14 lb ft).**

 **NOTE:** The supplied M8 x 1.25 x 60 threaded rods can be used on mounting thicknesses of 5-30 mm ($\frac{3}{16}$ " - $1\frac{3}{16}$ ") (recommended). For surfaces over 30 mm ($1\frac{3}{16}$ "), locally supplied longer threaded rods are needed.

Distance	Gauge
2 meters (6 1/2 ft)	16 AWG
4 meters (13 ft)	14 AWG
6 meters (19 ft)	12 AWG

Wire Gauge Table

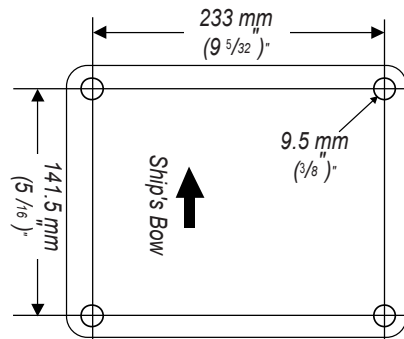

Figure 1

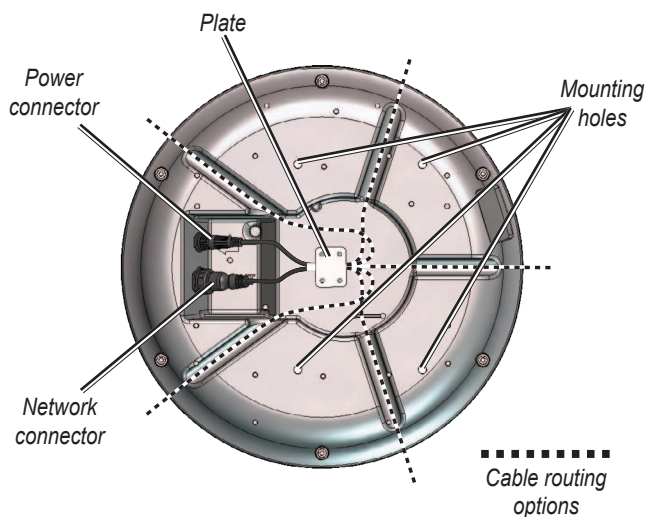

Figure 2

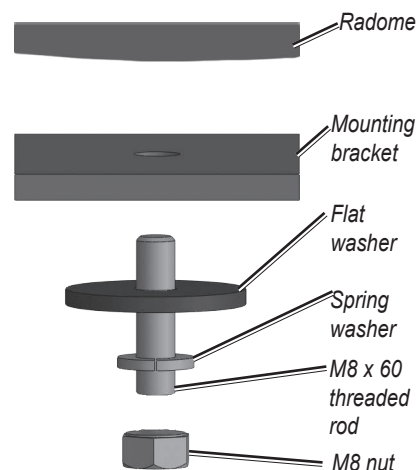

Figure 3

Cable Runs

Route the cables as needed, depending on the type of mount you are using. It may be necessary to drill 31.7 mm (1.25") holes for routing the power or network cable. Garmin provides a rubber cable grommet which may be used to cover a cable installation hole. The grommet does NOT provide a waterproof seal. To waterproof the grommet, apply a marine sealant. Additional cable grommets can be purchased through Garmin or a Garmin dealer.

When installing the power and network cables, observe the following:

- It is not recommended to cut the RJ-45 marine network cable, but the Garmin radome package includes a field install kit if it is necessary to do so. Make sure you save the end you cut. It is important that the wires are connected to the new RJ-45 connector the same way.
- To ensure safety, use the appropriate tie-wraps, fasteners, and sealant to secure the cable along a route and through any bulkhead or deck. Avoid running the cables near moving objects, high-heat sources, or through doorways and bilges.
- Avoid installing the cables next to or parallel to other cables, such as radio antenna lines or power cables. This is essential to avoid interference to or from other equipment. If this is not possible, shield the cables with metal conduit or a form of EMI shielding.
- Install the power cable as close to the battery source as possible. A minimum of 10.5 VDC is required during radar turn-on and operation. Reference the wire gauge table on the previous page when using extended runs of wire between the power cable and the battery.

Final Wiring Connections

Making the final wiring connections

1. Connect the Black ground (-) wire to the vessel's negative power terminal.
2. Connect the Red power (+) wire (with fuse holder) to the vessel's positive power terminal.

WARNING: Do not cut the fuse holder from the red wire. The fuse holder must remain in place for the Garmin radome to function correctly. Removing the inline fuse holder may damage your boat's circuitry.

3. For a stand-alone network (chartplotter and radar only), attach the RJ-45 marine network cable to the RJ-45 socket on the back of the chartplotter. For an expanded network (chartplotter, radar, GMS 10, etc.), attach the RJ-45 marine network cable to an open RJ-45 socket on the GMS 10 network port expander. Tighten the RJ-45 locking ring clockwise until it is firmly sealed.

NOTE: If you are using a Garmin GPSMAP 4000 or 5000 series chartplotter, you may not need a GMS 10 network port expander. The GPSMAP 4000 and 5000 series chartplotters have multiple RJ-45 sockets.

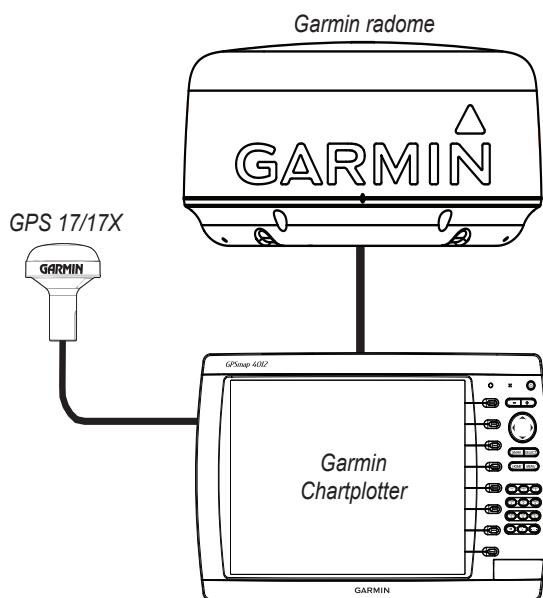

Stand-alone Network

NOTE: When using the Garmin radome with a stand-alone network, the chartplotter and GPS antenna (GPS 17) must be installed according to their installation instructions. This diagram only shows how a Garmin radome communicates with a stand-alone network and does not illustrate the full wiring needs of the chartplotter or GPS 17/17X.

NOTE: Both the Garmin radome and Garmin chartplotter must be connected to a power source according to their installation instructions. This diagram only illustrates the network data connections.

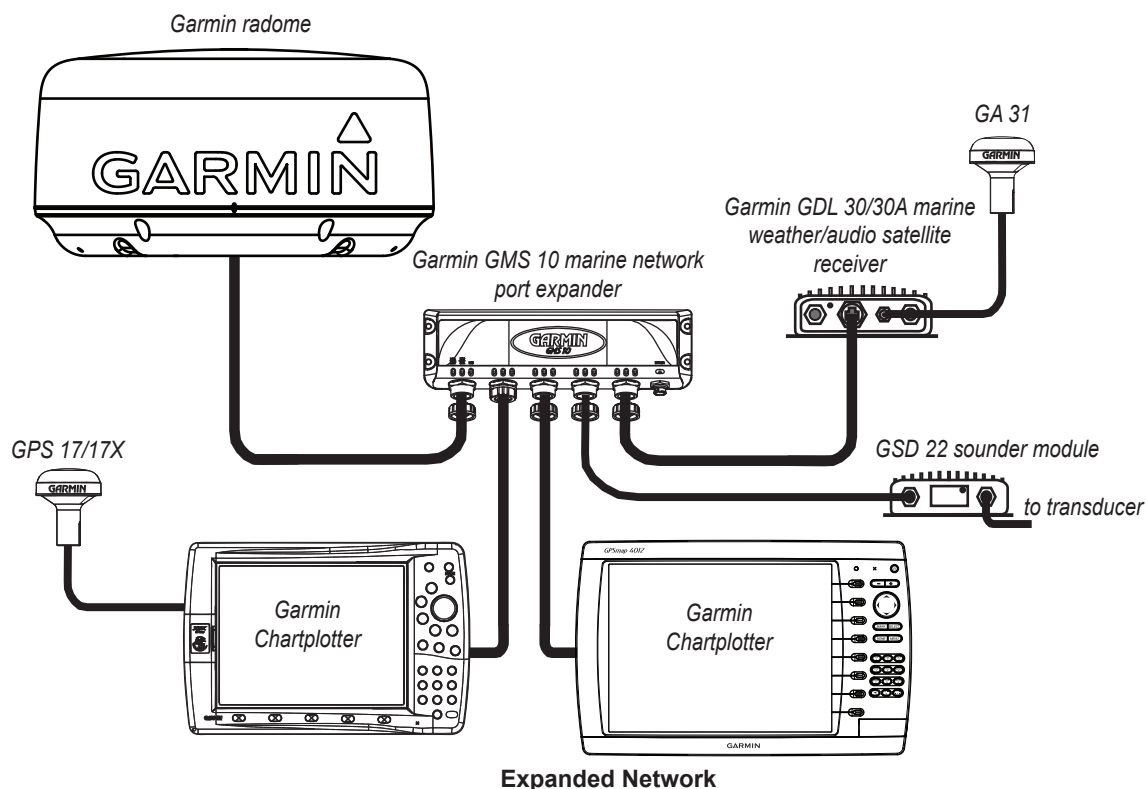

NOTE: When using the Garmin radome with an expanded network, each network component must be installed according to its installation instructions. This diagram only shows how a Garmin radome communicates with an expanded network, and does not show the full wiring needs of the other network components.

NOTE: The Garmin radome, Garmin chartplotter, and the other network components must be connected to a power source according to their installation instructions. This diagram only illustrates the network data connections.

Front of Boat Offset

Depending on the radome installation, it may be necessary to adjust the Front of Boat Offset. If the radome installation requires a 180° offset, change the Front of Boat Offset to 180° and test the radar. If the Front of Boat Offset needs further adjustment, continue with the procedure below.

Using the bow of the ship, take an optical bearing of a stationary target located within viewable range. Measure the target bearing on the radar. If the bearing deviation is more than +/- 1°, then do the following to access the Front of Boat Offset from the menu on your chartplotter:

Front of Boat Offset on a 3000 Series chartplotter:

1. From the Radar Page, press the **ADJ** key to display the Adjustment Menu.
2. From the Adjustment Menu, select **Setup**, and press **ENTER**. Using the **Rocker**, select the **Advanced** tab.
3. Using the **ROCKER**, highlight the **Front of Boat Offset** slider, and press **ENTER**.
4. Adjust the Front of Boat Offset.

Front of Boat Offset on a 4000/5000 Series chartplotter:

1. From the Home screen, select **Radar > Radar Setup > Advanced > Front Of Boat**.
2. Adjust the Front of Boat Offset.

Using the Radar

All functions of the Garmin radome are controlled using your Garmin marine network chartplotter. See the Radar section of your chartplotter's manual for operating instructions. If your chartplotter's manual does not contain a Radar section, download the latest revision of the manual from www.garmin.com/support/userManual.jsp

Specifications

GMR 18/18 HD

Unit Dimensions:	457 mm (18") D x 236 mm (9 1/4") H
Radar Radome Weight:	Unit 7.17 kg (15.8 lbs); cable 3.81 kg (8.4 lbs)
Range Scales:	1/8 nm (with 1/32 nm range rings) to 36 nm (with 9 nm range rings)
Power Output:	4 kW
Power Input Source:	10.5-35 VDC 33.5 W
Operating Temperature Range:	-15° C (5° F) to 60° C (140° F), and a relative humidity up to 95% at 35° C (95° F)
Beamwidth:	Horizontal beamwidth of 5° nominal / Vertical beamwidth of 25° nominal
Range:	66.67 km (36 nm)
Wind Velocity:	Wind speed up to 100 Kts
Antenna RPMs:	24 or 30 rpm
Minimum Range:	20 meters (65 feet)
Range Discrimination:	20 meters (65 feet)
RF Transmit Frequency:	9410 ± 30 MHz

GMR 24/24 HD

Unit Dimensions:	610 mm (24") D x 244 mm (9 5/8") H
Radar Radome Weight:	Unit 9.12 kg (20.1 lbs); cable 3.81 kg (8.4 lbs)
Range Scales:	1/8 nm (with 1/32 nm range rings) to 48 nm (with 12 nm range rings)
Power Output:	4 kW
Power Input Source:	10.5-35 VDC 33.5 W
Operating Temperature Range:	-15° C (5° F) to 60° C (140° F), and a relative humidity up to 95% at 35° C (95° F)
Beamwidth:	Horizontal beamwidth of 3.6° nominal / Vertical beamwidth of 25° nominal
Range:	88.89 km (48 nm)
Wind Velocity:	Wind speed up to 100 Kts
Antenna RPMs:	24 or 30 rpm
Minimum Range:	20 meters (65 feet)
Range Discrimination:	20 meters (65 feet)
RF Transmit Frequency:	9410 ± 30 MHz

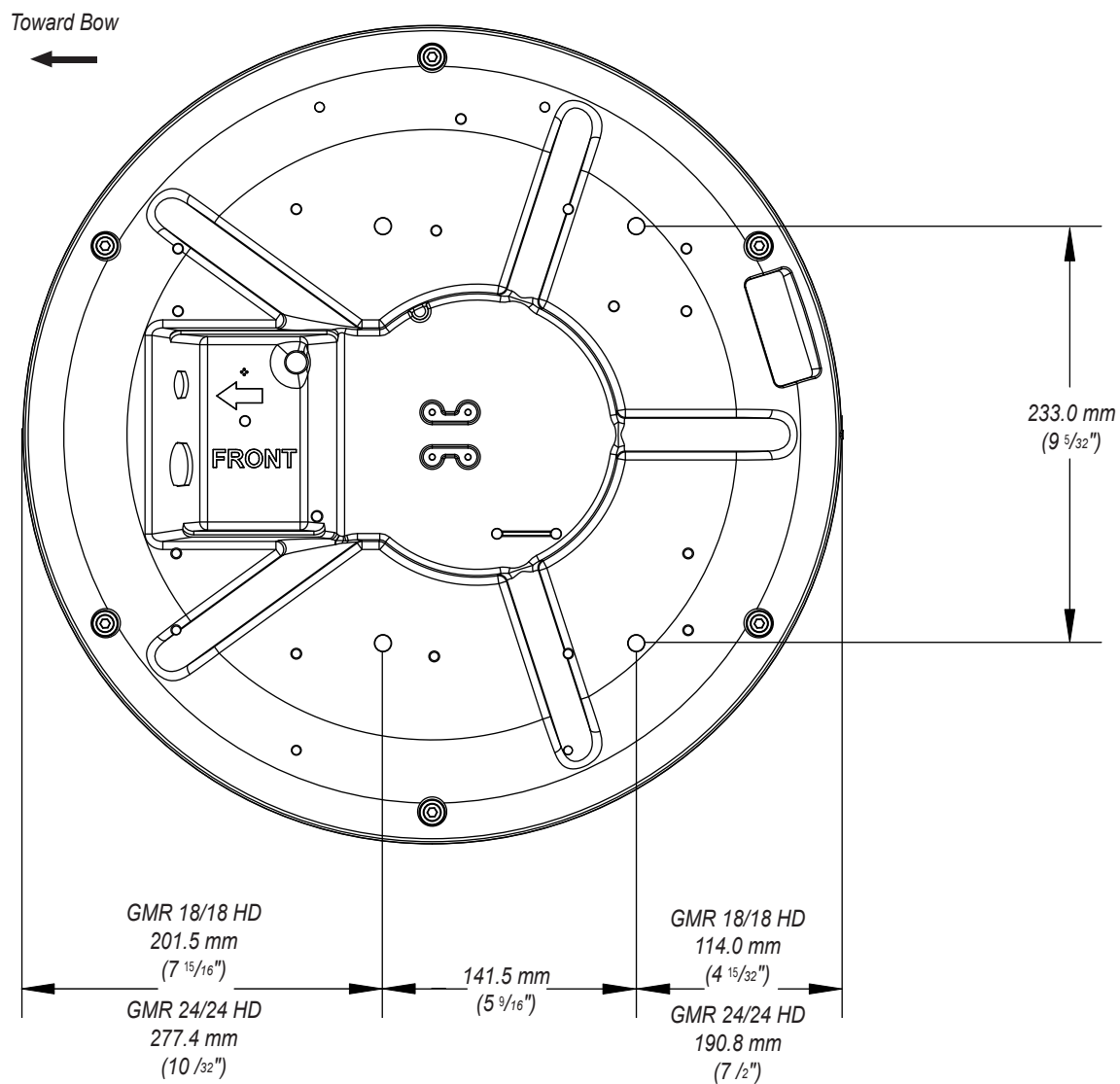
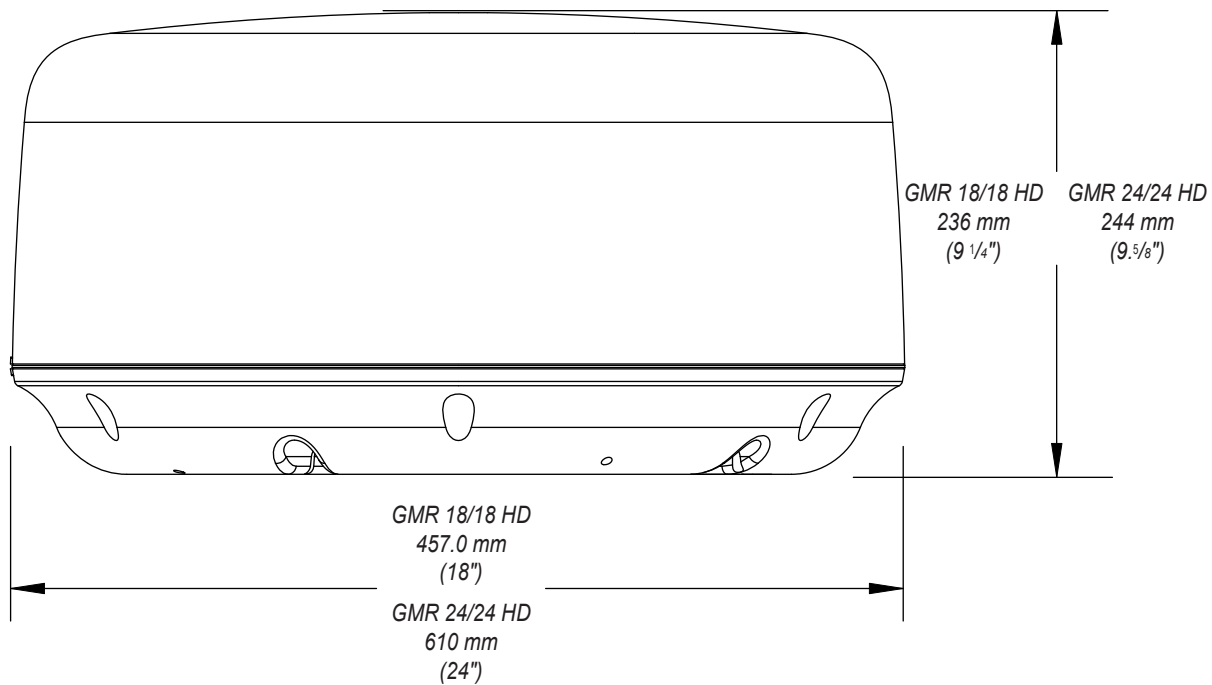

Warnings

Failure to avoid the following potentially hazardous situations could result in an accident or collision resulting in death or serious injury.

- The radar radome transmits electromagnetic energy. Ensure that the radome has been installed according to the recommendations given in this guide, and that all personnel are clear of the radome before switching to transmit mode.
- When navigating, carefully compare information displayed on the unit to all available navigation sources, including information from visual sightings, and maps. For safety, always resolve any discrepancies or questions before continuing navigation.
- Use the electronic chart in the unit only to facilitate, not to replace, the use of authorized government charts. Official government charts and notices to mariners contain all information needed to navigate safely.
- Use this unit only as a navigational aid. Do not attempt to use the unit for any purpose requiring precise measurement of direction, distance, location, or topography.

WARNING: Do not cut the fuse holder from the red wire. The fuse holder must remain in place for the Garmin radome to function correctly. Removing the inline fuse holder may damage your boat's circuitry.

WARNING: This product, its packaging, and its components contain chemicals known to the State of California to cause cancer, birth defects, or reproductive harm. This Notice is provided in accordance with California's Proposition 65. See www.garmin.com/prop65 for more information.

FCC Compliance

The GMR 18/24 and GMR 18 HD/24 HD comply with Part 80 of the FCC rules. It has received a grant of equipment authorization, issued under the authority of the FCC.

This equipment generates, uses, and can radiate radio frequency energy and, if not installed and used in accordance with the instructions, may cause harmful interference to radio communications. However, there is no guarantee that interference will not occur in a particular installation. If this equipment does cause harmful interference to radio or television reception, which can be determined by turning the equipment off and on, the user is encouraged to try to correct the interference by one of the following measures:

- Reorient or relocate the receiving antenna.
- Increase the separation between the equipment and the receiver.
- Connect the equipment into an outlet on a circuit different from that to which the receiver is connected.
- Consult the dealer or an experienced radio/TV technician for help.

Industry Canada Compliance

The GMR 18/24 and GMR 18 HD/24 HD radomes comply with Industry Canada Standard RSS-138.

Declaration of Conformity (DoC)

Hereby, Garmin, declares that this product is in compliance with the essential requirements and other relevant provisions of Directive 1999/5/EC. To view the full Declaration of Conformity, go to www.garmin.com/compliance.

Software License Agreement

BY USING THE GARMIN RADOME, YOU AGREE TO BE BOUND BY THE TERMS AND CONDITIONS OF THE FOLLOWING SOFTWARE LICENSE AGREEMENT. PLEASE READ THIS AGREEMENT CAREFULLY.

Garmin grants you a limited license to use the software embedded in this device (the "Software") in binary executable form in the normal operation of the product. Title, ownership rights, and intellectual property rights in and to the Software remain in Garmin.

You acknowledge that the Software is the property of Garmin and is protected under the United States of America copyright laws and international copyright treaties. You further acknowledge that the structure, organization, and code of the Software are valuable trade secrets of Garmin and that the Software in source code form remains a valuable trade secret of Garmin. You agree not to decompile, disassemble, modify, reverse assemble, reverse engineer, or reduce to human readable form the Software or any part thereof or create any derivative works based on the Software. You agree not to export or re-export the Software to any country in violation of the export control laws of the United States of America.

Limited Warranty

This Garmin product is warranted to be free from defects in materials or workmanship for one year from the date of purchase. Within this period, Garmin will, at its sole option, repair or replace any components that fail in normal use. Such repairs or replacement will be made at no charge to the customer for parts or labor, provided that the customer shall be responsible for any transportation cost. This warranty does not apply to: (i) cosmetic damage, such as scratches, nicks and dents; (ii) consumable parts, such as batteries, unless product damage has occurred due to a defect in materials or workmanship; (iii) damage caused by accident, abuse, misuse, water, flood, fire, or other acts of nature or external causes; (iv) damage caused by service performed by anyone who is not an authorized service provider of Garmin; or (v) damage to a product that has been modified or altered without the written permission of Garmin. In addition, Garmin reserves the right to refuse warranty claims against products or services that are obtained and/or used in contravention of the laws of any country.

This product is intended to be used only as a travel aid and must not be used for any purpose requiring precise measurement of direction, distance, location or topography. Garmin makes no warranty as to the accuracy or completeness of map data in this product.

THE WARRANTIES AND REMEDIES CONTAINED HEREIN ARE EXCLUSIVE AND IN LIEU OF ALL OTHER WARRANTIES EXPRESS, IMPLIED, OR STATUTORY, INCLUDING ANY LIABILITY ARISING UNDER ANY WARRANTY OF MERCHANTABILITY OR FITNESS FOR A PARTICULAR PURPOSE, STATUTORY OR OTHERWISE. THIS WARRANTY GIVES YOU SPECIFIC LEGAL RIGHTS, WHICH MAY VARY FROM STATE TO STATE.

IN NO EVENT SHALL GARMIN BE LIABLE FOR ANY INCIDENTAL, SPECIAL, INDIRECT OR CONSEQUENTIAL DAMAGES, INCLUDING, WITHOUT LIMITATION, DAMAGES FOR ANY TRAFFIC FINES OR CITATIONS, WHETHER RESULTING FROM THE USE, MISUSE OR INABILITY TO USE THE PRODUCT OR FROM DEFECTS IN THE PRODUCT. SOME STATES DO NOT ALLOW THE EXCLUSION OF INCIDENTAL OR CONSEQUENTIAL DAMAGES, SO THE ABOVE LIMITATIONS MAY NOT APPLY TO YOU.

Garmin retains the exclusive right to repair or replace (with a new or newly-overhauled replacement product) the device or software or offer a full refund of the purchase price at its sole discretion. SUCH REMEDY SHALL BE YOUR SOLE AND EXCLUSIVE REMEDY FOR ANY BREACH OF WARRANTY.

To obtain warranty service, contact your local Garmin authorized dealer or call Garmin Product Support for shipping instructions and an RMA tracking number. Securely pack the device and a copy of the original sales receipt, which is required as the proof of purchase for warranty repairs. Write the tracking number clearly on the outside of the package. Send the device, freight charges prepaid, to any Garmin warranty service station.

Online Auction Purchases: Products purchased through online auctions are not eligible for warranty coverage. Online auction confirmations are not accepted for warranty verification. To obtain warranty service, an original or copy of the sales receipt from the original retailer is required. Garmin will not replace missing components from any package purchased through an online auction.

International Purchases: A separate warranty may be provided by international distributors for devices purchased outside the United States depending on the country. If applicable, this warranty is provided by the local in-country distributor and this distributor provides local service for your device. Distributor warranties are only valid in the area of intended distribution. Devices purchased in the United States or Canada must be returned to the Garmin service center in the United Kingdom, the United States, Canada, or Taiwan for service.

Australian Purchases: Our goods come with guarantees that cannot be excluded under the Australian Consumer Law. You are entitled to a replacement or refund for a major failure and for compensation for any other reasonably foreseeable loss or damage. You are also entitled to have the goods repaired or replaced if the goods fail to be of acceptable quality and the failure does not amount to a major failure. The benefits under our Limited Warranty are in addition to other rights and remedies under applicable law in relation to the products.

Garmin Australasia
Unit 19, 167 Prospect Highway
Seven Hills, NSW, Australia, 2147
Phone: 1800 822 235

Garmin's Marine Warranty Policy: Certain Garmin Marine products in certain areas have a longer warranty period and additional terms and conditions. Go to www.garmin.com/support/warranty.html for more details and to see if your product is covered under Garmin's Marine Warranty Policy.

For the latest free software updates (excluding map data) throughout the life of your
Garmin products, visit the Garmin Web site at www.garmin.com.



© 2007 Garmin Ltd. or its subsidiaries

Garmin International, Inc.
1200 East 151st Street, Olathe, Kansas 66062, USA

Garmin (Europe) Ltd.
Liberty House, Hounslow Business Park, Southampton, Hampshire, SO40 9LR UK

Garmin Corporation
No. 68, Zhangshu 2nd Road, Xizhi Dist., New Taipei City, 221, Taiwan (R.O.C.)

www.garmin.com