

GPSMAP 168 Sounder

*chartplotting receiver
& depth-finder*



owner's
manual
and
reference
guide

© Copyright 2000-2002
GARMIN Ltd. or its subsidiaries
All Rights Reserved

Software Version 3.03 or above

Internal Database Version 2.00

GARMIN International, Inc. 1200 East 151st Street, Olathe, Kansas 66062, U.S.A.
Tel. 913/397.8200 or 800/800.1020 Fax 913/397.8282

GARMIN (Europe) Ltd. Unit 5, The Quadrangle, Abbey Park Industrial Estate, Romsey, SO51 9AQ, U.K.
Tel. 44/1794.519944 Fax 44/1794.519222

GARMIN Corporation No. 68, Jangshu 2nd Road, Shijr, Taipei County, Taiwan
Tel. 886/2.2642.9199 Fax 886/2.2642.9099

Except as expressly provided herein, no part of this manual may be reproduced, copied, transmitted, disseminated, downloaded or stored in any storage medium, for any purpose without the express prior written consent of GARMIN. GARMIN hereby grants permission to download a single copy of this manual and of any revision to this manual onto a hard drive or other electronic storage medium to be viewed and to print one copy of this manual or of any revision hereto, provided that such electronic or printed copy of this manual or revision must contain the complete text of this copyright notice and provided further that any unauthorized commercial distribution of this manual or any revision hereto is strictly prohibited.

Information in this document is subject to change without notice. GARMIN reserves the right to change or improve its products and to make changes in the content without obligation to notify any person or organization of such changes or improvements.

Introduction

Foreword



GARMIN®, *Autolocate®*, *See-Thru®*, *DCG (Depth Control Gain)®* and *TracBack®* are registered trademarks, and *MapSource™* is a trademark of GARMIN Corporation and may not be used without the express permission of GARMIN Corporation.

Introduction

Preface and Registration



Why should you register your GARMIN GPS unit:

- Notification of Product Updates
- Notification of New Products
- Lost or Stolen unit tracking

Preface

Congratulations on choosing one of the most advanced depth sounding and marine navigation systems available! The GARMIN GPSMAP 168 Sounder utilizes the proven performance of GARMIN GPS and full featured depth sounding and mapping to create an unsurpassed marine navigation chartplotter and fishfinding package.

To get the most out of your new navigation and sounding system, take the time to go through this owner's manual and learn the operating procedures for your unit. This manual is broken down into two parts for your convenience.

Part One introduces you to the GPSMAP 168 Sounder and provides a Getting Started tour so you may become more familiar with the unit. This section will provide you with a basic working knowledge necessary to use the unit to its fullest potential.

Part Two is divided into sections that provide detailed references to the advanced features and operations of the GPSMAP 168 Sounder. This allows you to concentrate on a specific topic quickly and look up detailed information about the GPSMAP 168 Sounder.

Customer Service Product Registration

Help us better support you by completing our on-line registration today! Have the serial number of your GPSMAP 168 Sounder handy and connect to our website (www.garmin.com). Look for the Product Registration link on the Home page. Also, be sure to record your serial number in the area provided on page iv of this manual.



NOTE: If you have previously registered a GARMIN product purchase using a mail-in registration card, we invite you to re-register using our NEW on-line system. Many services provided by our new product registration system are now being automated. Re-registering your purchase ensures you the best possible support from GARMIN.

The GPS system is operated by the United States government, which is solely responsible for its accuracy and maintenance. The system is subject to changes which could affect the accuracy and performance of all GPS equipment. Although the GARMIN GPSMAP 168 Sounder is a precision electronic NAVigation AID (NAVAID), any NAVAID can be misused or misinterpreted and, therefore, become unsafe.

The electronic chart is an aid to navigation and is designed to facilitate the use of authorized government charts, not replace them. Only official government charts and notices to mariners contain all information needed for safe navigation – and, as always, the user is responsible for their prudent use.

Use the GPSMAP 168 Sounder at your own risk. To reduce the risk of unsafe operation, carefully review and understand all aspects of this Owner's Manual—and thoroughly practice operation using the simulator mode prior to actual use. When in actual use, carefully compare indications from the GPSMAP 168 Sounder to all available navigation sources, including the information from other NAVAIDs, visual sightings, charts, etc. For safety, always resolve any discrepancies before continuing navigation.

The GPSMAP 168 Sounder should not be used as a navigational aid or depth sounder to prevent collision, grounding, boat damage or personal injury. The digital depth displayed is the depth under the transducer and not necessarily the front of the boat. By the time a depth is displayed, most of your boat may have already passed over that area. We recommend that you operate the boat at a very slow speed if you suspect shallow water or submerged objects.



CAUTION: IT IS THE USER'S RESPONSIBILITY TO USE THIS PRODUCT PRUDENTLY. THIS PRODUCT IS INTENDED TO BE USED ONLY AS A NAVIGATIONAL AID AND MUST NOT BE USED FOR ANY PURPOSE REQUIRING PRECISE MEASUREMENT OF DIRECTION, DISTANCE, LOCATION, OR TOPOGRAPHY.

Introduction

Warnings and Precautions

MAP DATA INFORMATION: One of the goals of GARMIN is to provide customers with the most complete and accurate cartography that is available to us at a reasonable cost. We use a combination of governmental and private data sources, which we identify (as required) in product literature and copyright messages displayed to the consumer. Virtually all data sources contain inaccurate or incomplete data to some degree. This is particularly true outside the United States, where complete and accurate digital data is either not available or prohibitively expensive.

Software License Agreement

Software License Agreement

BY USING THE GPSMAP 168 SOUNDER, YOU AGREE TO BE BOUND BY THE TERMS AND CONDITIONS OF THE FOLLOWING SOFTWARE LICENSE AGREEMENT. PLEASE READ THIS AGREEMENT CAREFULLY.

GARMIN grants you a limited license to use the software embedded in this device (the “Software”) in binary executable form in the normal operation of the product. Title, ownership rights and intellectual property rights in and to the Software remain in GARMIN.

You acknowledge that the Software is the property of GARMIN and is protected under the United States of America copyright laws and international copyright treaties. You further acknowledge that the structure, organization and code of the Software are valuable trade secrets of GARMIN and that the Software in source code form remains a valuable trade secret of GARMIN. You agree not to decompile, disassemble, modify, reverse assemble, reverse engineer or reduce to human readable form the Software or any part thereof or create any derivative works based on the Software. You agree not to export or re-export the Software to any country in violation of the export control laws of the United States of America.

WARNING

These products are intended for recreational fishfinding and as a aid for navigation and should not be relied on as a substitute for official marine navigation charts. It is the user’s responsibility to be aware of shallow water and underwater hazards and to exercise common prudence and navigational judgment.

FCC Compliance

The GPSMAP 168 Sounder complies with Part 15 of the FCC interference limits for Class B digital devices FOR HOME OR OFFICE USE. These limits are designed to provide reasonable protection against harmful interference in a residential installation, and are more stringent than “outdoor” requirements.

Operation of this device is subject to the following conditions: (1) This device may not cause harmful interference, and (2) this device must accept any interference received, including interference that may cause undesired operation.

This equipment generates, uses and can radiate radio frequency energy and, if not installed and used in accordance with the instructions, may cause harmful interference to radio communications. However, there is no guarantee that interference will not occur in a particular installation. If this equipment does cause harmful interference to radio or television reception, which can be determined by turning the equipment off and on, the user is encouraged to try to correct the interference by one or more of the following measures:

- Reorient or relocate the receiving antenna.
- Increase the separation between the equipment and receiver.
- Connect the equipment into a different outlet or circuit than the one that is currently being used.
- Consult the dealer or an experienced radio/TV technician for help.

The GPSMAP 168 Sounder does not contain any user-serviceable parts. Repairs should only be made by an authorized GARMIN service center. Unauthorized repairs or modifications could result in permanent damage to the equipment, and void your warranty and your authority to operate this device under Part 15 regulations.

Introduction

FCC Compliance

Introduction

Warranty and Serial Number

Serial Number

Use this area to record the serial number (8-digit number located on the bottom of the unit) in case it is lost, stolen, or needs service. Be sure to keep your original sales receipt in a safe place or attach a photocopy inside the manual.

Serial Number:

--	--	--	--	--	--	--	--



The GARMIN GPSMAP 168 Sounder has no user-serviceable parts. The GPSMAP 168 Sounder is fastened shut with screws. Any attempt to open the case to change or modify the unit in any way will void your warranty and may result in permanent damage to the equipment.

LIMITED WARRANTY

This GARMIN product is warranted to be free from defects in materials or workmanship for one year from the date of purchase. Within this period, GARMIN will at its sole option, repair or replace any components that fail in normal use. Such repairs or replacement will be made at no charge to the customer for parts or labor, provided that the customer shall be responsible for any transportation cost. This warranty does not cover failures due to abuse, misuse, accident or unauthorized alteration or repairs.

THE WARRANTIES AND REMEDIES CONTAINED HEREIN ARE EXCLUSIVE AND IN LIEU OF ALL OTHER WARRANTIES EXPRESS OR IMPLIED OR STATUTORY, INCLUDING ANY LIABILITY ARISING UNDER ANY WARRANTY OF MERCHANTABILITY OR FITNESS FOR A PARTICULAR PURPOSE, STATUTORY OR OTHERWISE. THIS WARRANTY GIVES YOU SPECIFIC LEGAL RIGHTS, WHICH MAY VARY FROM STATE TO STATE.

IN NO EVENT SHALL GARMIN BE LIABLE FOR ANY INCIDENTAL, SPECIAL, INDIRECT OR CONSEQUENTIAL DAMAGES, WHETHER RESULTING FROM THE USE, MISUSE, OR INABILITY TO USE THIS PRODUCT OR FROM DEFECTS IN THE PRODUCT. Some states do not allow the exclusion of incidental or consequential damages, so the above limitations may not apply to you.

GARMIN retains the exclusive right to repair or replace the unit or software or offer a full refund of the purchase price at its sole discretion. SUCH REMEDY SHALL BE YOUR SOLE AND EXCLUSIVE REMEDY FOR ANY BREACH OF WARRANTY.

To obtain warranty service, contact your local GARMIN authorized dealer. Or call GARMIN Customer Service at one of the numbers shown below, for shipping instructions and an RMA tracking number. The unit should be securely packed with the tracking number clearly written on the outside of the package. The unit should then be sent, freight charges prepaid, to any GARMIN warranty service station. A copy of the original sales receipt is required as the proof of purchase for warranty repairs.

GARMIN International, Inc.
1200 East 151st Street
Olathe, Kansas 66062, U.S.A.
Phone: 913/397.8200
FAX: 913/397.0836

GARMIN (Europe) Ltd.
Unit 4, The Quadrangle, Abbey Park Industrial Estate
Romsey, SO51 9AQ, U.K.
Phone: 44/1794.519944
FAX: 44/1794.519222

Designed for detailed electronic charting capability, the GARMIN GPSMAP 168 Sounder is a powerful navigation device that can give you the navigation information you need:

Precision Performance

- High-contrast, four-level gray, LCD screen with backlighting
- 12-channel parallel receiver tracks and uses up to 12 satellites for fast, accurate positioning
- Differential-Ready — just add an optional GARMIN beacon receiver for better than 5-meter accuracy
- Fully gasketed, high-impact plastic alloy case, waterproof to IEC 529-IPX-7

Advanced Navigating and Plotting

- 500 alphanumeric waypoints with selectable icons
- Built-in Americas basemap to 20 miles includes detailed ocean, river and lake coastlines, cities, interstates, US state highways and local thoroughfares
- 20 reversible routes with up to 30 waypoints each
- Uploadable maps up to 2.5 Megabytes of data using GARMIN's MapSource PC products
- Coordinates: Lat/Lon, UTM/UPS, Loran TD, plus 15 grids, including Maidenhead
- TracBack route feature which allows you to quickly retrace your track log to a starting position
- Built-in simulator mode

Superior Fishfinding Ability

- Whiteline feature provides a clear image of both bottom hardness and structure
- See-Thru technology which helps separate fish returns from thermoclines and structure
- Four zoom levels with a moving view window
- Underwater waypoint marking
- Map/Sonar split screen combines navigation and fishfinding information
- Fish and depth alarms

Introduction

Packing List



GPSMAP 168 Sounder

Standard and Optional Transducers

Unit part numbers 010-00199-00 and 010-00202-00 include a 200 kHz, 20 degree, plastic, depth and temp, transom mount transducer. For a complete list of optional transducers, see page 93.

Before installing and getting started with your unit, please check to see that your package includes the following items. **If any parts are missing, please contact your GARMIN dealer immediately.**

Standard Package:

- GPSMAP 168 Sounder Unit
- Bail Mount with knobs
- Mounting Bracket*
- Mount Bracket with Internal Antenna**
- GA 29 Remote Marine Antenna with 30' cable and BNC connector*
- Power/Data Cable
- AC Power/PC Interface Cable
- Protective Cover
- Owner's Manual and Quick Reference Guide

* Not included with part number 010-00202-00 or 010-00202-02.

** Not included with part number 010-00199-00 or 010-00199-02.

Optional Accessories:

- US A/C PC Adapter
- EURO A/C PC Adapter
- UK A/C PC Adapter
- Cigarette Lighter Adapter
- MapSource CDs: Fishing Hot Spots, US Waterways & Lights, US Topo, US Roads & Recreation, European Roads & Recreation, and WorldMap
- Beacon Receiver for differential corrections: GBR21 (E-Field Antenna, GBR23 (H-Field Antenna,)
- 2nd Mounting Station
- Quick Release Flush Mounting Kit
- Marine Swivel Mount, 1" RAM® Mount

Introduction	i-viii
Foreword	i
Preface and Registration	ii
Warnings and Precautions	iii
Warranty and Serial Number	iv
Capabilities	v
Packing List	vi
“How To” Index	viii
Section One: Getting Started	1-19
Keypad Usage, Selecting Options, Entering Data, Initializing the Receiver, Power On/Off, Contrast, Backlighting, Simulator, Description of Main Pages, Simulated Tour	
Section Two: Reference	20-82
Status Page and Options	21
Map Page and Options	24
Map Page Configuration	32
Sonar Page and Options	38
Sonar Page Configuration	42
Compass Page and Options	45
Highway Page and Options	46
Waypoints	48
Creating	48
Reviewing and Editing	50
Waypoint List	52
Nearest and Proximity	54

Going to a Destination	56
TracBack	58
MOB	60
Routes	61
Creating	61
Reviewing and Editing	63
Active Route Page	68
Main Menu Page	69
Track Tab	70
Trip, Time and Pages Tabs	72
System Tab	73
Units Tab	74
Communication Tab	76
Alarm Tab	78
Celestial Tab	80
Tides Tab	81
Appendix A: Loran TD	83
Appendix B: Time Offsets	85
Appendix C: Messages	86
Appendix D: Map Datums	88
Appendix E: Navigation Terms	90
Appendix F: Specifications	92
Appendix G: Installation	93
Appendix H: Understanding Sonar	103
Appendix I: Advanced NMEA Setup	108
Appendix J: Index	109

Introduction

Table of Contents

Introduction

“How To” Index



The list to the right is provided to help you quickly find some of the more important procedures you will use on your new GPSMAP 168 Sounder.

TO DO THIS:	SEE PAGE(S):
Turn the unit on or off	4, 6, 19
Initialize the GPS receiver (first time use)	4-5
Adjust screen contrast or backlighting	6-7
Enter data and select options	2-3
Operate the unit's function keys	1
Mark your present location as a waypoint	10, 48
Go to a destination	11, 56-60
Create and use a route	61-68
Learn about the Map page	8-9, 24-26
Pan using the map arrow	9, 25
Zoom in or out on the Map page	9, 29
Reconfigure the Map page display	30-37
Access the Main Menu	18, 69
Change units of measure (statute, nautical, metric)	74-75
Change the displayed time (zone)	72
Setup Loran TD	84
View tide information	81-82
View celestial information	80
Set alarms	78-79
See current position, date and time	8, 20
View a unit message	86-87

The IN Key

The **IN** key adjusts the map scale to display a smaller area with more detail. (Zooms in)

The OUT Key

The **OUT** key adjusts the map scale to display a larger area with less detail. (Zooms out)

The PAGE Key

The **PAGE** key selects the main pages in sequence and returns display from a submenu page.

The ARROW KEYPAD

The **ARROW KEYPAD** is used to select (Highlight) menu options and enter data. It also controls cursor movement on the Map Page.

The ENTER/MARK Key

The **ENTER/MARK** key selects a highlighted menu option. When entering data, it allows you to initiate entry, and then to accept the selected value(s). It also marks the current location as a waypoint when pressed and held for more than one second.

The QUIT Key

The **QUIT** key returns the display to the previous page and, when entering data, it restores the previous value (cancels data entry).

The MENU Key

The **MENU** key displays a menu of available options for the current page. Press twice to display the Main Menu.

The NAV/MOB Key

The **NAV/MOB** key displays the Go To and Follow navigation menu. It also activates the MOB (Man OverBoard) function when pressed and held for more than one second.

The POWER/BACKLIGHT/CONTRAST Key (☞)

The **POWER/BACKLIGHT/CONTRAST** key turns the unit and display illumination on/off .

Getting Started

Keypad Usage



*Always press and release a key to perform its primary function. Pressing and holding the **ENTER/MARK** or **NAV/MOB** keys will activate their secondary function.*

Getting Started

Selecting Options



Use the **ARROW KEYPAD** to highlight the next option. Press **ENTER/MARK** to activate the option.

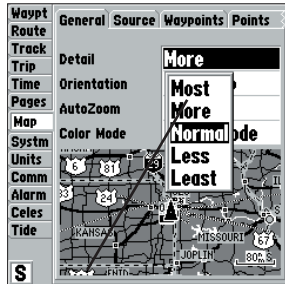

Pop-up list of options for a highlighted field.

How To Select Options and Enter Data

Before moving ahead into GPSMAP 168 features, you will need to learn basic operation. You can select and activate options and enter data to customize the GPSMAP 168 to fit your requirements. You can use the **ENTER/MARK** key and **ARROW KEYPAD** to select options, enter names and numbers in data fields, and activate your selections.

To select and activate an optional feature:

1. With any page displayed, press the **MENU** key to pop-up the options menu. The options menu will display a list of optional features which are specific for that particular page. To select any feature on the list of options requires movement of the cursor, which is identified as highlighting, selecting or choosing an item in a list or a field (box) on a page.
2. Use the **ARROW KEYPAD** to move the cursor (highlight) up and down a list or up, down, and sideways on menus.
3. Once you have moved to the selection desired, press the **ENTER/MARK** key to either activate the feature or pop-up a sub-menu or list of yet more feature options. Just repeat this process to select an option from the list or press the **QUIT** key to return to the previous setting.

The **QUIT** key when pressed, will move backwards through each step to the main page you started on.

To select and activate a function button:

1. When moving about a page with function buttons, like the 'New Map Waypoint' page, you will observe functions such as 'OK', 'Go To' and 'Delete'. To activate the function, highlight the desired button and press the **ENTER/MARK** key.

Naming a waypoint or placing any sort of data that has not been predefined requires the use of both the **ARROW KEYPAD** and the **ENTER/MARK** key.

To enter a name or number in a data field:

- Once you have accessed a page with programmable data fields (i.e. 'Waypoint Edit') you can use the **ARROW KEYPAD** to move the cursor (highlight) to fields on the page. Use the UP/DOWN arrows to move up or down and the LEFT/RIGHT arrows to move sideways.
- Pressing the **ENTER/MARK** key with the field highlighted begins the process for entering data in the form of alphanumeric characters.
- Use the **ARROW KEYPAD** UP/DOWN arrows to cycle through numbers 0 to 9, plus/minus symbols, blank space, and the alphabet. Pressing and releasing the keypad moves you character by character through the list. Pressing and holding the keypad moves you rapidly through the list.
- Use the **ARROW KEYPAD** LEFT/RIGHT arrows to move to the next character on the line or backwards to edit characters. If there are more than two lines of data, keep pressing to the RIGHT to drop down to the next line.
- When data entry is completed, press **ENTER/MARK** to accept data, then move to the next programmable field. Not all data fields are programmable, like the date and time. When moving about a page with these type of fields, the cursor will skip over them.

Every field and button on this page can be programmed or activated.

- A waypoint symbol can be selected from a list of symbols.
- The coordinates can be changed.
- The waypoint can be renamed.
- A depth will be set by the sonar.
- Option buttons can be activated.

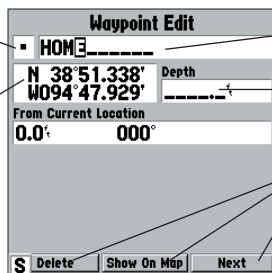

Getting Started

Entering Data

N 28°28.327'
W082°42.401'

N 28°28.328'
W082°42.401'



Pressing UP or DOWN on the ARROW KEYPAD changes numbers and letters.

N 28°28.328'
W082°42.401'

N 28°28.328'
W082°42.401'



Pressing LEFT or RIGHT on the ARROW KEYPAD moves the cursor along the line or to the next line.

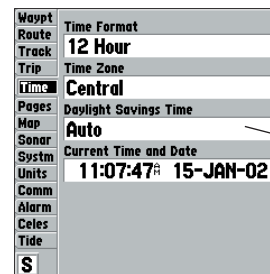

Getting Started

Initializing the Receiver

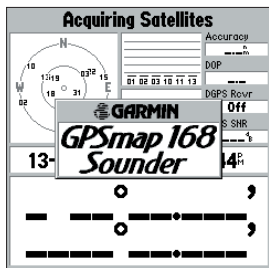

GPSMAP 168 Sounder Self-Test Screen

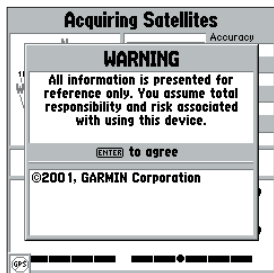

GPSMAP 168 Sounder Warning Screen

The GPSMAP 168 Sounder's advanced keypad system is designed to allow for fast, convenient selection of navigation options and data entry. The Getting Started Tour will introduce you to the keypad and provide a “hands-on” lesson in using the GPSMAP 168 Sounder. We strongly encourage you to take the Getting Started tour before using your unit for actual navigation.

The GPSMAP 168 Sounder Quick Reference Guide contains helpful tips on using the unit and performing various navigation tasks. It's a good idea to keep the Quick Reference Guide nearby whenever you're operating your new GPSMAP 168 Sounder.

Initializing the Receiver

The first time you power up your new GPSMAP 168 Sounder, the receiver must be given an opportunity to collect satellite data and establish its present position. To ensure proper initialization, the GPSMAP 168 Sounder is shipped from the factory in AutoLocate mode, which will allow the receiver to “find itself” anywhere in the world. To speed up the initialization process, we recommend using the graphic initialization process described on the next page, which will usually provide a position fix within a few minutes.

Before you initialize, make sure the GPSMAP 168 Sounder unit and antenna have been correctly installed on your vessel according to the instructions in Appendix G. The antenna needs to be in a clear and unobstructed view of the sky to receive satellite signals.

To turn on the GPSMAP 168 Sounder:

1. Press and hold the **POWER** key until the power tone sounds and the display comes on, then release the **POWER** key.

The Welcome Page will appear while the unit conducts a self-test. Once the internal test is complete, a warning page will appear, asking you to read and acknowledge important information regarding the proper use of the unit.

To acknowledge the warning:

1. After reading the warning, press the **ENTER/MARK** key if you agree.

Initializing the Receiver

To graphically initialize the GPSMAP 168 Sounder:

1. From the Status Page, press the **MENU** key. The Status Page options menu window will appear.
2. Using the **ARROW KEYPAD**, highlight 'Initialize Position' and press **ENTER/MARK** to initialize the receiver from the built-in worldwide map. The Initialize Position Page will appear, prompting you to select your approximate location with the map cursor.
3. Use the **ARROW KEYPAD** to move the map cursor and point to your approximate location within 100 miles. If you have difficulty identifying your position, press and release the **IN** key to zoom in to see the next lower map scale.
4. Once you have determined your approximate location on the map, press the **ENTER/MARK** key.



This does not "calibrate" the unit in any way, but rather helps to speed up the initial satellite acquisition. If the unit switches to the Map Page or displays '2D' or '3D Navigation' during this process, it is not necessary to initialize the unit.

The GPSMAP 168 Sounder will now begin searching for the appropriate satellites for your region and should acquire a fix within a few minutes. A signal strength bar for each satellite in view will appear on the top middle of the page, with the appropriate satellite number under each bar. The progress of satellite acquisition is shown in three stages:

- No signal strength bars—the receiver is looking for the satellites indicated.
- Hollow signal strength bars—the receiver has found the indicated satellite(s) and is collecting data.
- Solid signal strength bars—the receiver has collected the necessary data and the satellite(s) are ready for use.

Once the receiver has collected information from at least three satellites, the top of the screen will display either '2D' or '3D Navigation', and the GPSMAP 168 Sounder is ready for use.

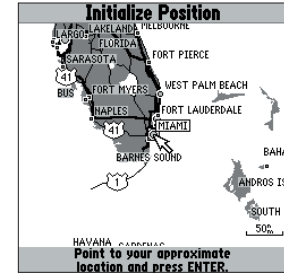

Point to your approximate location and press **ENTER/MARK**.

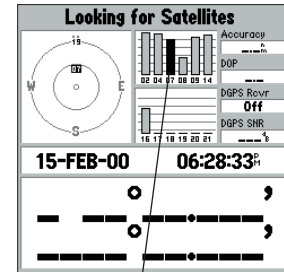

A satellite's strength bars will turn black when it's ready for use.

Getting Started

Power On — Screen Contrast

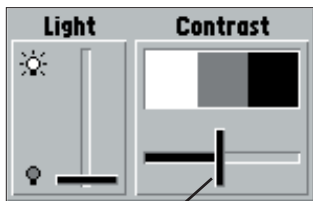

To adjust the screen contrast, press **LEFT** or **RIGHT** on the **ARROW KEYPAD** to move the contrast slider.

GPSMAP 168 Sounder Getting Started Tour

The GARMIN GPSMAP 168 Sounder is a powerful electronic navigation system that provides detailed map coverage and convenient control of many advanced features right from the screen display. This tour is designed to take you through the basic pages and functions of the system using the simulator mode. Once you're familiar with the main pages and functions of the unit, refer to the Reference section for instructions on performing specific tasks and functions.

The Getting Started tour assumes that the receiver has been properly installed and initialized, and you have not changed any of the default unit settings. If you have changed any settings (position formats, units of measure, etc.), the descriptions and pictures in the tour may not match your configuration.

To turn on the GPSMAP 168 Sounder:

1. Press and hold the **POWER** key until the power tone sounds, then release the **POWER** key. The Welcome Page will appear while the unit conducts a self-test.
2. Once the self-test is complete, press the **ENTER/MARK** key, if you agree, to acknowledge the warning.

The Status Page will appear as the receiver begins acquiring satellites. From the Status Page or any other page, you may also adjust the screen contrast and backlighting.

To adjust the screen contrast:

1. Press **POWER** and the Light and Contrast window will appear.
2. To decrease or increase the screen contrast, press **LEFT** or **RIGHT** on the **ARROW KEYPAD**.
3. Press the **ENTER/MARK** key to finish.

The GPSMAP 168 Sounder adjustable screen backlighting is controlled with the **POWER** key, and may be adjusted at any time from any page. The backlight can cycle through off, user-defined, and maximum backlight levels by repeatedly pressing the **POWER** key.

Backlighting/ Simulator Mode

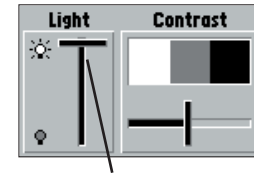

Press UP or DOWN on the ARROW KEYPAD to move the backlighting slider up for brighter or down for dimmer backlighting..

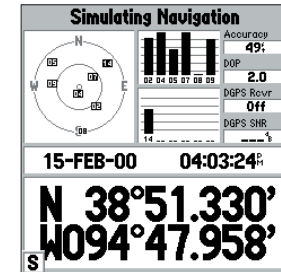

When the unit is in simulator mode, an 'S' will appear in the lower left corner of every screen and the Status Page will show "Simulating Navigation."

To turn on and adjust the backlighting:

1. Press **POWER** and the Light and Contrast window will appear.
2. Press **POWER** again and the user-defined level of backlighting will activate. You may adjust this level by pressing UP or DOWN on the **ARROW KEYPAD**. If you press **POWER** one more time, the backlighting will be at the maximum setting.
3. Press **ENTER/MARK** or **QUIT** when done.

The backlight will now cycle through off, the user-defined, and maximum backlight levels by repeatedly pressing the **POWER** key.

The GPSMAP 168 Sounder's Status Page provides a visual reference of satellite acquisition, receiver status, date, time and position coordinates. Each page of the GPSMAP 168 Sounder's system also features an options menu, giving you access to other functions and features related to the specific page you are viewing. To get a feel for how the options menus work, let's put the GPSMAP 168 Sounder into simulator mode.

To place the GPSMAP 168 Sounder in simulator mode:

1. From the Status Page, press the **MENU** key. A menu of options and functions for the Status Page will appear.
2. Press UP or DOWN on the **ARROW KEYPAD** to highlight the 'Start Simulator' option and press **ENTER/MARK**.
3. Press the **ENTER/MARK** key to confirm the 'Running Simulator' message that appears at the bottom of the display.

Once the simulator has been started, the status field at the top of the page will display a 'Simulating Navigation' status. Now you're ready to continue the rest of the simulated tour.



The GPSMAP 168 Sounder does not track satellites in simulator mode, and this mode should never be used for actual navigation.

All the waypoint and route planning done in simulator mode will still be retained in memory for future use.

Getting Started

Status Page/Map Page

The Status Page is one of six main pages used in the GPSMAP 168 Sounder's system. The six main pages are: the Status Page, Sonar Page, Map Page, Compass Page, Highway Page and Active Route Page. All six pages are linked together in a simple chain, which allows you to scroll through the pages in either direction using the **PAGE** and **QUIT** keys.

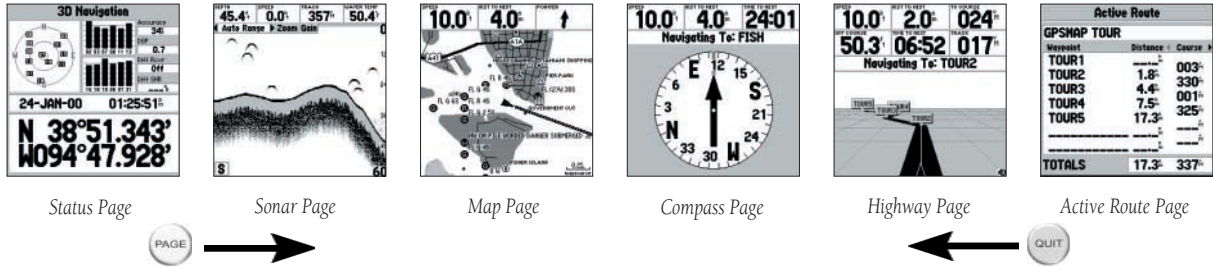

To continue the tour, let's move on to the next page, the Map Page.

To scroll to the next page in sequence:

1. Press the **PAGE** key.

The GPSMAP 168 Sounder's Map Page combines digital chartplotting with a user-selectable display of navigation data and a built-in worldwide database to 20 mi. It will also be the page you use most to create and edit waypoints and routes. Before we take off on our practice route, let's take a brief look at its various features and displays.

The map display shows your "boat" as a triangle marker on an electronically generated chart. Geographic names, roads, markers and buoys that are provided by the optional MapSource data are also shown. It also displays your track, routes and nearby waypoints. An on-screen cursor lets you pan to other map areas, determine the range and bearing to a position, and perform various waypoint and route functions.

The data window, located at the top of the page, provides a user-selectable display of various navigation data, including course, speed over ground, and bearing and distance to the cursor or a particular waypoint. The current map scale setting is located at the bottom right of the page.

Using the Map Cursor

Working from the Map Page is a simple process that centers around the use of the cursor. Controlled by the **ARROW KEYPAD**, the cursor is an important tool that can be used to pan to other map locations, mark and edit waypoints and routes, and review position data of on-screen map items and waypoints.

To get a feel for using the Map Page and using the cursor, try the following exercise:

1. Use the **IN/OUT** keys to set the map scale to the 50 nm setting. Your boat should be near the center of the map, at the receiver's last known position. (If your boat isn't where it should be, make sure that you have initialized the receiver and acquired a position as described on pages 1-2.)
2. Use the **ARROW KEYPAD** to move the cursor. Notice how another data field appears at the top of the page, showing the bearing and distance from your boat to the cursor, along with the latitude/longitude of the cursor.
3. Press the **QUIT** key to remove the cursor and re-center your boat on the map display.

As you become more familiar with the cursor, you'll see that the map display actively scrolls or 'pans', letting you explore areas around the world and create waypoints and routes. Wherever you move the cursor, you'll always be just one **QUIT** keystroke away from returning the map to your present position.

Now that you've seen how the Status and Map Pages can be used to monitor satellite acquisition and your present location, let's take a minute to learn how to mark and store your present position as a waypoint. Since you're in simulator mode, the present position displayed will be the last position calculated by the receiver, which should be the spot where you've initialized the unit. This will also give you an opportunity to see how the GPSMAP 168 Sounder's **ARROW KEYPAD** and **ENTER/MARK** key are used for data entry and changing the waypoint name and symbol.

Getting Started

Map Cursor

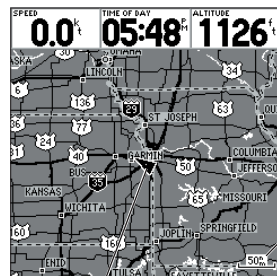

Current position

Map Scale

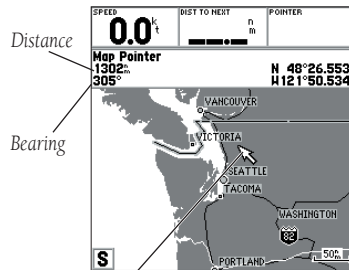

Distance

Bearing

Map Cursor

Cursor Coordinates

Getting Started

Marking Waypoints

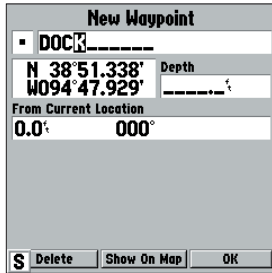

Press **ENTER/MARK** after entering the name.

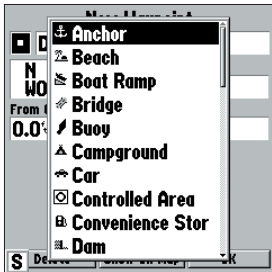

You can choose from a list of 38 useful symbols.

To mark your present position:

1. Hold down the **ENTER/MARK** key until the 'New Waypoint' window appears then release the key. The window will show a default three-digit waypoint name/number (001), symbol (dot), and position. You can leave the name as the auto-assigned number, but for this exercise, let's change the name to 'DOCK'.
2. Use the **ARROW KEYPAD** to highlight the waypoint name field (001) and press **ENTER/MARK**. You will see that just the first '0' is now highlighted.
3. Press LEFT on the **ARROW KEYPAD** to clear the name field.
4. Press the UP or DOWN arrow of the **ARROW KEYPAD** until the letter 'D' appears, and then press the RIGHT arrow key to go to the next space to the right, then UP or DOWN again until 'O' appears. Repeat this until you have entered the name 'DOCK'. If you make a mistake and select an incorrect character, simply press LEFT on the **ARROW KEYPAD** to backspace the cursor and then UP or DOWN to correct the entry. If you accidentally press **ENTER/MARK** before you are done, simply press **ENTER/MARK** again and move the highlight to where you left off.
5. After you have entered all the letters, press **ENTER/MARK** to confirm the name.
6. To access the waypoint symbol menu, highlight the waypoint symbol field which is to the left of the waypoint's name and press **ENTER/MARK**. Note: The default symbol is a dot.
7. You will see an alphabetical list of available waypoint symbols to choose from. Press the **ARROW KEYPAD** UP or DOWN until you highlight the 'ANCHOR' symbol. You will see a scroll bar on the right of the window indicating your current position on the entire list of symbols.
8. Press **ENTER/MARK** to confirm the 'ANCHOR' symbol.
9. Highlight 'OK' at the bottom of the window and press **ENTER/MARK** again to confirm the 'OK' prompt and save the waypoint. You may also press **QUIT** to not save the waypoint.

The waypoint is now stored in memory. Note that waypoints may also be created graphically from the map display or by manually entering position coordinates. Each of these techniques is described in the reference section of the manual and/or on your GPSMAP 168 Sounder Quick Reference Guide.

Going to a Destination

GPS is all about marking positions as waypoints and navigating to them using the receiver's steering guidance and map displays. We've already seen how to use the **ENTER/MARK** key to store our present position, so it's time to move on to the fun part—going to a destination.

The **NAV/MOB** key is the primary tool used to select a destination waypoint, TracBack, or a route to navigate. The **NAV/MOB** key can be used in three primary ways:

- Pressing **NAV/MOB** once displays a list of options from which you can select 'Go To Point', 'Follow Route', 'Follow Track', or 'Stop Navigation'.
- Holding down or pressing twice on the **NAV/MOB** key activates the MOB (Man OverBoard) feature. This marks the point at which the MOB was activated as a waypoint named "MOB" and also establishes it as an active "Go To" point.
- Highlighting an on-screen waypoint or map item as a destination directly from the Map Page and pressing **NAV/MOB** allows you to graphically select points to "Go To".

For our simulated trip, you're going to select a pre-programmed tour route using the first method. This will also show how the **MENU** key is used throughout the GPSMAP 168 Sounder system to provide tab style options and functions. Let's start by changing the position to where the practice route is located.

To change the GPSMAP 168 Sounder position in simulator mode:

1. From the Status Page, press the **MENU** key. A pop-up window will appear, displaying a list of options and functions for the Status Page.
2. Press UP or DOWN on the **ARROW KEYPAD** to highlight the 'Initialize Position' option and press **ENTER/MARK**.
3. From the Initialize Position Page, press the **MENU** key. You will see 'Enter As Text' highlighted, then press **ENTER/MARK**.
4. On the Enter Position window, press **ENTER/MARK** then use the **ARROW KEYPAD** to enter N34°56.800', press the **ARROW KEYPAD** right to move to the next line then enter W076°24.066'. Press **ENTER/MARK** when finished.

Getting Started

Using the NAV/MOB Key

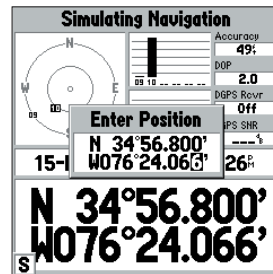

Text entry for simulator position.

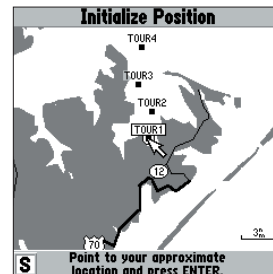

For future practice, you may skip steps 3 and 4 and point to a location from the Initialize Position page.

Getting Started

Simulated Tour

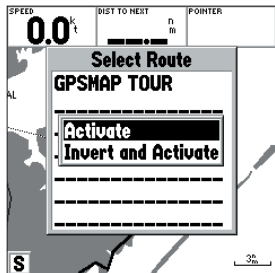

You can also Invert a route to follow it in reverse.

Waypt	Beeper	
Route	Off	
Track	Off	
Trip	Speed Filter	
Time	Auto	
Pages	Language	
Map	English	
Sonar	English	
System	System Mode	
Units	Simulator	Set Position
Comm	Track Control	Track
Alarm	Auto Track	357 ^{ft}
Ceas	Speed	Transducer
Tide	0.0 ^{ft}	Temp
S		

The 'Set Position', 'Track Control', 'Track' and 'Speed' fields only show while in simulator mode.

Let's give it a try by activating the practice route stored in memory for navigation:

1. Press **NAV/MOB**. The options list will appear. (If we were selecting a single waypoint to navigate to rather than a route, we could highlight the waypoint on the map, press **NAV/MOB** and then press **ENTER/MARK**.)
2. Use the **ARROW KEYPAD** to highlight the 'Follow Route' option. Press **ENTER/MARK** to confirm.
3. The Select Route page will appear, with the 'GPSMAP TOUR' route highlighted.
4. Press **ENTER/MARK** then highlight 'Activate' and press **ENTER/MARK** again.

To get a better view of what's going on, zoom in to a closer map scale:

1. Repeatedly press the **IN** key until you select the 3 nm scale.

Note: You may also hold down the **IN** or **OUT** key to quickly scroll through the map scales. The Map Page should now display five waypoints chained together in a simple route, with your boat at the first route waypoint.

A data field at the top of the page will now display the speed, distance to the second route waypoint, and a pointer which shows you which way to go. To get started, let's enter a speed for our vessel, which we can do from the Main Menu Page.

To enter a boat speed:

1. Press the **MENU** key twice to display the Main Menu Page.
2. Use the **ARROW KEYPAD** to highlight the 'System' tab, then press **RIGHT** then **DOWN** until the field below the word 'Speed' is highlighted and press **ENTER/MARK**.
3. Use the **ARROW KEYPAD** to enter a speed of 60 knots.
4. Press **ENTER/MARK** to finish, and **QUIT** until you return to the Map Page.

Once a speed has been entered, you'll notice that the map will automatically begin to move slowly, keeping your boat centered on the display. The direction of movement, also called 'track', will be controlled by the simulator.

Getting Started

You'll now have a clearer picture of the route you are navigating. Keep in mind that whenever you do exceed the usable range of the built-in database or the optional MapSource data in use, the range field will display 'overzoom' or 'NO MAP' to indicate that you should exercise extreme caution using the map data. Press the **IN** key to zoom into the 2 nm scale. Now that you've zoomed in a little closer to your route, you can pan ahead of your vessel with the cursor to review map items and create on-screen waypoints. Try moving the cursor to highlight the 'TOUR3' waypoint— just use the **ARROW KEYPAD** to move the cursor as close as possible to the waypoint. (To move the cursor in small increments, try a series of short key presses.)

Once the cursor is over the TOUR3 waypoint, you'll notice that the waypoint symbol and name will become highlighted or "selected." The data field at the top of the page will display the waypoint name, the range and bearing from your present position, and the coordinates for the waypoint.

To review the waypoint page for a selected waypoint:

1. Press the **ENTER/MARK** key.
2. To return to the Map Page, press **ENTER/MARK** again or press **QUIT**.

The cursor can also be used to create new waypoints right from the map display.

To create a new waypoint using the cursor:

1. Use the **ARROW KEYPAD** to move the cursor to a new position on the map that is NOT a map feature (such as a city, road or lake).
2. Press the **ENTER/MARK** key to capture the cursor position. The New Map Waypoint page appears.
3. Use the **ARROW KEYPAD** to highlight the waypoint symbol field to the left of the waypoint name/number.
4. Press **ENTER/MARK** to access the symbol page.
5. Press UP or DOWN on the **ARROW KEYPAD** to select the 'Shipwreck' symbol and press **ENTER/MARK** to confirm.
6. Highlight 'OK' at the bottom and press **ENTER/MARK** again to save the waypoint.

Reviewing/Creating Map Waypoints

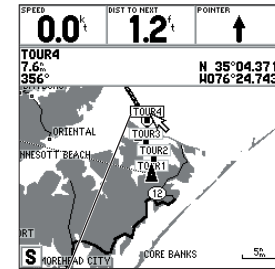

The waypoint will 'highlight' when the cursor is moved over it.

New Map Waypoint	
010	
N 36°52.279'	Depth
W 084°23.578'	-----'
From Current Location	
695.2°	343°
S Delete	Show On Map OK

Waypoint numbering will start with 001 and continually count up, even if the waypoint name has been deleted.

Getting Started

Sonar Page

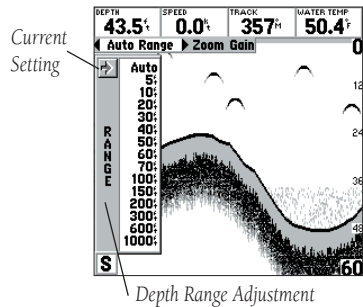
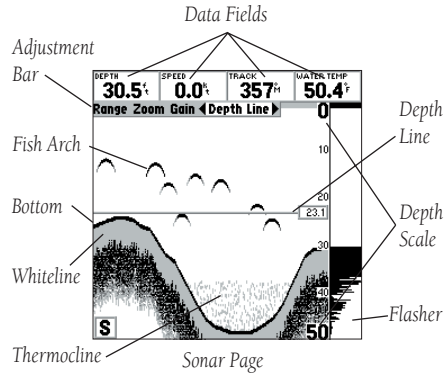

The Sonar Page lets you use the GPSMAP 168 Sounder as a fishfinder. The top of the screen contains any of 27 selectable data field options, while the middle of the page contains a right-to-left moving sonar image of the water beneath your boat. (Note: Items appear on the screen as they pass under your transducer. Those objects appearing on the right side of the screen are closer to you than those on the left.) Fish are displayed as a darkened arch or a fish icon in three different sizes. Thermoclines (layers of water separating warmer water above from cooler water below) are shown as shades of gray.

The area of strongest sonar return (or whiteline) is displayed as solid gray. Typically, the bottom will be the primary source of the whiteline. A thin whiteline indicates a softer bottom while a thick whiteline shows a harder bottom. A black line is used to show the point where water meets the whiteline. This black line will follow the bottom contour, along with any significant objects lying on the bottom. Along the right side of the screen is an adjustable scale which reflects the depth of the area being displayed. If the unit does not detect a transducer attached to the unit, a "Sonar Turned Off" message will appear across the top of the Sonar Page. More on the Sonar Page may be found on pages 38-44.

The GPSMAP 168 Sounder uses two range modes: auto and manual. Auto mode displays the most information possible while continuously showing the bottom. Manual mode lets you select the displayed depth. These and other Sonar Page functions are controlled from the adjustment bar.

To switch from auto to manual mode:

1. With the 'Range' field highlighted, press the **ARROW KEYPAD UP** or **DOWN** until the desired depth range is displayed on the adjustment bar or shows on the depth scale in the lower right side of the page.
2. Press **ENTER/MARK** or press **LEFT** or **RIGHT** on the **ARROW KEYPAD** to confirm the selected range.

To switch from manual to auto mode:

1. With the 'Range' field highlighted, press the **ARROW KEYPAD UP** or **DOWN** until the selection arrow points to 'Auto' or 'Auto' is displayed on the adjustment bar.
2. Press **ENTER/MARK** or press **LEFT** or **RIGHT** on the **ARROW KEYPAD**.

Another useful feature of the GPSMAP 168 Sounder is the sonar zoom, which allows you to instantly “zoom in” to look at a specific portion of the sonar display by using the either the **IN** or **OUT** key. The Zoom function is divided into four display levels:

- 2X Split—Shows two reduced-size sonar pictures at the same time. The right half of the display screen shows the complete sonar picture at its original scale. The left half shows a portion of the original picture at 1/2 depth scale.
- 2X Zoom—Displays the 2X zoomed picture on the full GPSMAP 168 Sounder screen and does not show the original scale picture.
- 4X Split—Shows two reduced pictures, with one at the original depth scale and one at 1/4 the original depth scale.
- 4X Zoom—Displays only the 4X zoomed picture on the full GPSMAP 168 Sounder screen.

Once activated, the zoomed picture becomes the Sonar Page display. Note: The Zoom function can be deactivated by pressing the **OUT** key until the ‘No Zoom’ setting appears.

Once in Zoom mode, you can control the view of the left side of the split. When the unit is set to one of the Zoom settings, and additional optional named ‘View’ will appear on the adjustment bar. The View function operates in either ‘Auto View’ or ‘Fixed View’. Auto View will follow the bottom contour while Fixed View will display the selected depth.

To access the Sonar Zoom function:

1. While viewing the Sonar Page, press **IN** once. The 2X split screen will appear.
2. Continue to press **IN** to advance to further zoom screen levels.
3. To deactivate the Zoom function, press **OUT** until the original scale (No Zoom) appears.
4. Press **ENTER/MARK** or press LEFT or RIGHT on the **ARROW KEYPAD**.

For more on the Zoom, View and other Sonar Page functions, see pages 38-44.

To learn more about how sonar works, see Appendix H.

Getting Started

Sonar Page

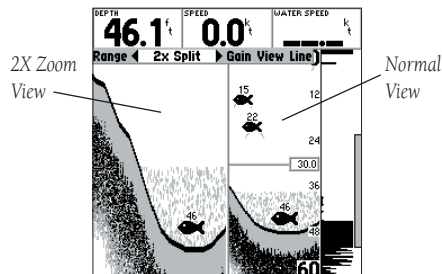

Sonar 2X Split Screen (shown with Depth Line and Flasher)

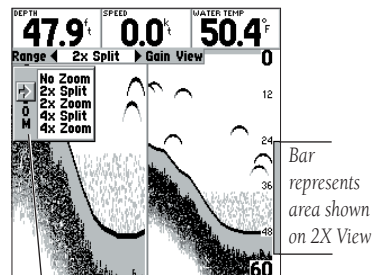

Sonar Zoom Adjustment

Getting Started

Compass/Highway Navigation Pages

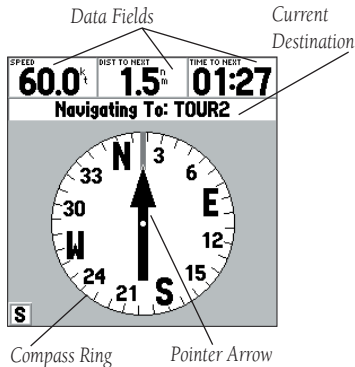

Now that we're navigating to an actual destination, let's move on to the GPSMAP 168 Sounder navigation pages by pressing the **PAGE** key.

The GPSMAP 168 Sounder features two different navigation pages: Compass and Highway. The Compass Page is first. This page provides graphic steering guidance to a destination waypoint, with an emphasis on the bearing to your destination and current direction of travel (the Highway Page places greater emphasis on the straight-line desired course and the distance and direction you are off course). The middle of the page features a rotating 'compass ring' that shows your course over ground (track) while you're moving, and a bearing pointer that indicates the direction of the destination (bearing) relative to the course over ground. The compass ring and pointer arrow work independently to show—at a glance—the direction of your movement and the direction to your destination. For instance, if the arrow points up, you are going directly to the waypoint. If the arrow points any direction other than up, turn toward the arrow until it points up—then continue in that direction.

The current speed and distance to the next waypoint as well as the time to the next waypoint are displayed at the top of the screen. This page provides better steering guidance than the Highway Page when travelling at slower speeds and/or when making frequent directional changes. When you are not navigating to a waypoint, the compass will show your direction of travel as you move but the arrow will not appear. Note: Due to Selective Availability error, it is possible for the compass to point in the wrong direction when stationary or at very low speeds.

Let's move on to the Highway Page by pressing the **PAGE** key.

Getting Started

Highway Page

The GPSMAP 168 Sounder's Highway Page also provides graphic steering guidance to a destination waypoint. As you head toward your destination, the middle of the screen provides visual guidance to your waypoint on a moving graphic "highway." Your present position is at the bottom center of the highway display. The line down the middle of the highway represents your desired course. As you navigate toward a waypoint, the highway will actually move—indicating the direction you're off course. To stay on course, simply steer toward the center of the highway or "keep it on the road." The six default data fields at the top of the page indicate Speed, Distance To your destination (or the next waypoint in a route), 'To Course' (which shows the bearing to get you back on course), the distance you are 'Off Course', Time To the Next waypoint, and the compass Track you are heading. Use the Highway Page as your primary navigation page (in lieu of the Compass Page) when your main concern is following a defined course.

When the GPSMAP 168 Sounder is in simulator mode, you can also adjust your speed and course from the Highway Page using the **ARROW KEYPAD**. As you head toward each waypoint in the tour route, try adjusting your boat speed and course to get a feel for how the highway works.

To adjust the simulated boat speed from the Highway Page:

1. Press the UP arrow of the **ARROW KEYPAD** to increase the speed in 10 knot/kph/mpH increments. Press the DOWN arrow to decrease the speed in the same increments.

To steer the boat:

1. Press the LEFT and RIGHT arrows of the **ARROW KEYPAD**.

Notice that as you get off course, the highway will move to give you graphic guidance to get back on course. You can zoom IN or OUT on the highway display for a smaller or larger view. Five available settings range from 1X to 16X, with a default setting of 8X. The current scale will appear in the bottom right of the display.

To zoom in or out on the highway display:

1. Press either the **IN** or **OUT** key to increase or decrease the zoom scale.

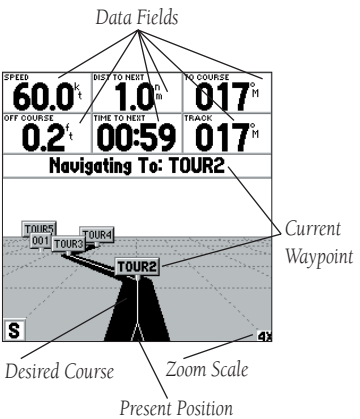

Getting Started

Data Fields/Active Route Page/ Main Menu Page

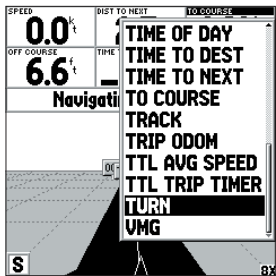

You may choose from 27 different types of data.

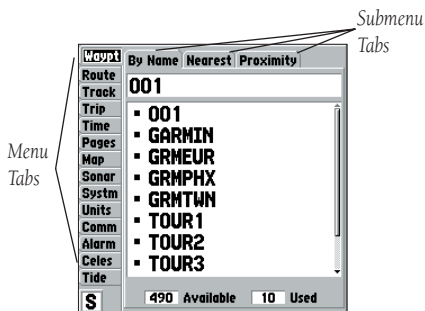

The main pages' (except the Status and Active Route Pages) data fields may also be configured to display any of 27 different information categories (see page 36-37 for the complete list). On the Highway Page, let's change the 'TO COURSE' field to 'TURN'.

To change a data field:

1. Press the **MENU** key to display the Highway Page options.
2. Press DOWN on the **ARROW KEYPAD**, highlight 'Change Data Fields' and press **ENTER/MARK**.
3. Once the menu window disappears, use the **ARROW KEYPAD** and highlight 'TO COURSE', then press **ENTER/MARK**.
4. On the alphabetical list of options, press the **ARROW KEYPAD UP** or **DOWN** until you highlight 'TURN' and press **ENTER/MARK**.
5. Press **QUIT** when done.

Press **PAGE** to see the last page appearing in the main sequence, which is the Active Route Page. Whenever you have activated a route or TracBack, this page will show each waypoint name along with useful data for each point. As you navigate the route, the information will automatically update to indicate the next point along the route, which is denoted by an arrow on the left-hand side of the screen. For more detailed information on the Active Route Page, see page 68.

As you've seen, the primary pages provide status, map, and navigation information. The tour's last page is the Main Menu Page, which allows access to the GPSMAP 168 Sounder's waypoint, route and planning functions, various operational and navigation setup features, and celestial and tide data.

The Main Menu is available from any page, and is accessed through the **MENU** key.

To access the Main Menu Page:

1. Press the **MENU** key twice.

The Main Menu Page lists 14 menu 'tabs' that are divided into categories by function. You can view a particular menu by simply highlighting the desired tab, which will then show any secondary submenu tabs and options for that tab.

To get a feel for how the Main Menu Page works, let's clear out the track log. This will ensure that you have a clean slate once you start navigating in your home waters.

To select the Track submenu tab:

1. Use the **ARROW KEYPAD** to highlight the 'Track' menu tab. You will see the options for the Track tab appear to the right of the Main Menu list.
2. Press to the right one time on the **ARROW KEYPAD** and you will see 'Active' highlighted.

The Track Log Page allows you to specify whether to record a track plot, define how it is recorded and save your current track log. It also provides both an indicator of the percentage of total memory used and the individual options to save or clear the active track log.

To clear the active track log:

1. Highlight the 'Clear' option and press **ENTER/MARK**. A confirmation page will appear.
2. Highlight the 'OK' prompt and press **ENTER/MARK** to confirm.
3. Press **PAGE** or **QUIT** to return to any of the main pages.

Congratulations! You've now gone through the basic operation of the GARMIN GPSMAP 168 Sounder. Your new digital chartplotter is a powerful tool with many advanced features not covered in the Getting Started tour. For detailed instructions on using these features or performing a specific task, please refer to the Quick Reference Guide or the appropriate reference section of this manual.

To turn off the GPSMAP 168 Sounder:

1. Press and hold the **POWER** key for about 2 seconds, until the screen is blank.
2. When the screen is blank, release the **POWER** key.

The next section of the manual describes the pages and functions of the GPSMAP 168 Sounder in detail. If you are unable to locate a specific option or function, please refer to the index on pages 105-107. Thank you for choosing the GARMIN GPSMAP 168 Sounder navigation unit. We hope it will be a useful and fun tool for you wherever you go!

Getting Started

Deleting Track Logs/ Powering Off Unit

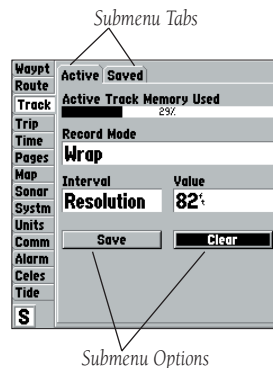

Reference

Status Page

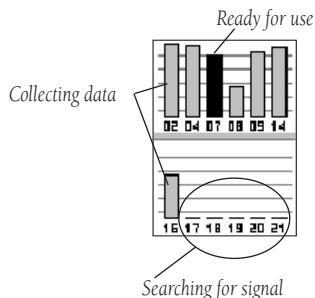
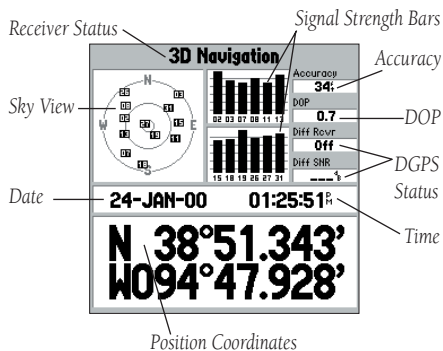

Status Page

The GPSMAP 168 Sounder Status Page provides a visual reference of satellite acquisition, receiver status, date, time and position coordinates. The status information will give you an idea of what the receiver is doing at any given moment. The sky view and signal strength bars give you an indication of what satellites are visible to the receiver and whether or not they are being tracked. The signal strength is shown on a bar graph for each satellite, with the satellite number below. As the receiver locks onto satellites, a signal strength bar will appear for each satellite in view, with the appropriate satellite number (01-32) underneath each bar. The progress of satellite acquisition is shown in three stages:

- No signal strength bars—the receiver is looking for the satellites indicated.
- Light signal strength bars—the receiver has found the satellite(s) and is collecting data.
- Dark signal strength bars—the receiver has collected the necessary data and the satellite(s) are ready for use.

Each satellite has a data transmission that must be collected (light bar status) before that satellite may be used for navigation (dark bar status). When the receiver is looking for a particular satellite, the corresponding signal strength bar will be blank and the sky view indicator will not be highlighted. Once the receiver has found the satellite, a light signal strength bar will appear, indicating that the satellite has been found. When the receiver has collected data from the satellite and locked on, the number in the sky view will appear highlighted and the status bar will become dark.

As soon as the GPSMAP 168 Sounder has collected the necessary data from the best satellites in view to calculate a fix, the status field will indicate a 2D or 3D status. The unit will then update the position, date and time.

You can use the sky view to help determine if any satellites are being blocked, and whether you have a current position fix (indicated by a '2D Navigation' or '3D Navigation' in the status field). The sky view shows a bird's-eye view of the position of each satellite relative to the receiver's last known position. The outer circle represents the horizon (north up), the inner circle 45° above the horizon, and the center point a position directly overhead. You can also set the sky view to a 'Track Up' configuration, causing the top of the sky view to align along your current track heading.

Receiver Status, Accuracy and DOP

Receiver status is indicated at the top field of the page, with the current Accuracy and Dilution Of Precision (DOP) to the right of the sky view. DOP is an indication of satellite geometry quality measured on a scale of one to ten (lowest numbers the best, highest numbers the poorest). Accuracy uses DOP and other factors to calculate horizontal position accuracy in feet or meters. The status field will show one of the following conditions:

- Looking For Satellites— the receiver is looking for any satellites.
- AutoLocate— the receiver is looking for any satellite whose almanac has been collected. This process can take up to five minutes.
- Acquiring Satellites— the receiver is looking for and collecting data from satellites visible at its last known or initialized position, but has not collected enough data to calculate a fix.
- 2D Navigation— at least three satellites with good geometry have been acquired and a 2 dimensional position fix (latitude and longitude) is being calculated. '2D Differential Navigation' will appear when you are receiving DGPS corrections in 2D mode and a 'D' will show on the strength bar of satellites being corrected.
- 3D Navigation— at least four satellites with good geometry have been acquired and your position is now being calculated in latitude, longitude and altitude. '3D Differential Navigation' will appear when you are receiving DGPS corrections in 3D mode and a 'D' will show on the strength bar of satellites being corrected.
- Poor GPS Coverage— the receiver is no longer tracking enough satellites for a 2D or 3D fix.
- Receiver Not Usable— the receiver is unusable, possibly due to interference or abnormal satellite conditions. Turn the unit off and back on to reset.
- Simulating Navigation— the receiver is in simulator mode.

Reference

Status Page Options

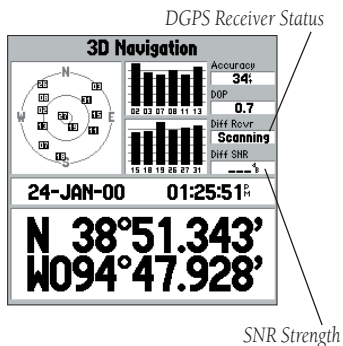

The 'DGPS Rcvr' and 'Diff SNR' fields appear below the 'Accuracy' and 'DOP' fields. The Differential Receiver status will show one of the following:

- Off— No optional beacon receiver attached or enabled in the Comm menu
- No Signal— DGPS receiver attached, but not transmitting RTCM data to GPS
- Tuning— Receiver is tuning manual frequency
- Scanning— DGPS receiver is scanning for available frequency
- Rcvng— Unit is receiving DGPS corrections
- Chk Wiring— DGPS is enabled in Comm menu, but no DGPS receiver attached or bad corrections
- WAAS— The unit is receiving 'WAAS' data

The Differential SNR (Signal to Noise Ratio) indicates, on a scale to 0-30db with 30db being the best, the strength of the DGPS signal being received. If no optional DGPS receiver is used with the GPSMAP 168 Sounder, the 'DGPS Rcvr' field will display 'Off' and the 'DGPS SNR' field will be blank. The SNR will depend upon the mounting of your DGPS receiver and the distance from the DGPS transmitting station.

Many features of the GPSMAP 168 Sounder are menu driven. Each of the main pages has an options menu, allowing you to custom tailor the corresponding page to your preferences and/or select special features that specifically relate to that page.

The GPSMAP 168 Sounder's Status Page features an options menu that provides access to functions and features relating to the Status Page.

To display the Status Page options:

1. Press **MENU**.

To select a menu option:

1. Using the **ARROW KEYPAD**, highlight the desired option and press **ENTER/MARK**.

The following options are available:

- Start/Stop Simulator— allows you put the unit in simulator mode. See the Getting Started Tour for more on using simulator mode.
- Enable/Disable WAAS— allows you to activate or deactivate WAAS. ‘WAAS’ is an acronym for ‘Wide Area Augmentation System’. You can use the WAAS capability to increase the accuracy of the GPSMAP 168 Sounder. When enabled, the GPS receiver searches for a WAAS satellite, then receives data that will help correct differentials in the GPS signal. When the unit is using WAAS data, “WAAS” will be displayed in the ‘DGPS Rcvr’ field on the Status Page, and the receiver status will indicate a 2D or 3D Differential Location.

Currently, the WAAS system is not fully operational and there are only two satellites in place—one over the Pacific Ocean and one over the Atlantic Ocean. You must have a clear, unobstructed view of the sky for the GPSMAP 168 Sounder to be able to receive a WAAS signal. Even then, at times it may not be possible to receive a WAAS signal. For more information on the WAAS system, visit the Federal Aviation Administration web site at (gps.faa.gov).

- Track Up/North Up— allows you to select between a north up or track up sky view display for the Status Page only.
- Loran TD On/Off— allows you to toggle the position coordinate format between latitude/longitude and Loran TD (Time Delays). For setup of Loran TD, see pages 83-84.
- AutoLocate— allows the receiver to locate your position automatically. This process can take up to five minutes.
- Initialize Position— allows you to initialize the receiver graphically on the Map Page to initially help the receiver acquire more quickly. See pages 4-5 for instructions on initialization.
- Set 2D Elevation— allows you to manually enter the altitude when in 2D Navigation or Simulator mode only. Any altitude entered will be automatically calculated when the GPS is in 3D Navigation mode.

Status Page Options

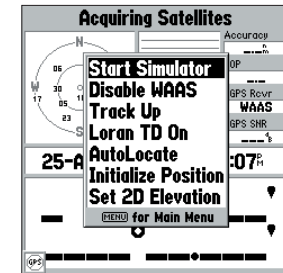

Status Page Options

Reference

Map Page

Map Page

The GPSMAP 168 Sounder's Map Page provides a comprehensive display of electronic cartography, plotting and navigational data. When using the unit with the optional MapSource software, the map display shows your boat on a digital chart, complete with geographic names, map items, nav aids and a host of other chart features. It also plots your track and displays any routes and waypoints you create. An on-screen cursor lets you pan and scroll to other map areas, determine the distance and bearing to a position, and perform various route and waypoint functions.

When the cursor is active, an additional data window will appear below the data fields to indicate the position, range and bearing to the cursor or a selected waypoint or map item. The map scale displays at the bottom right corner of the page.

The **IN** and **OUT** keys, combined with the **ARROW KEYPAD**, let you select zoom ranges and move the cursor. Two basic map operating modes, position mode and cursor mode, determine what cartography is shown on the map display. Position mode pans the cartography to keep the present position marker within the display area, while cursor mode pans the cartography to keep the cursor within the display area.

The GPSMAP system will always power up in the position mode, with your vessel centered on the map display.

- When sufficient map coverage is not available to keep the boat centered, the boat icon will move toward the edge of the display.
- If the boat icon attempts to go off the display, the zoom level may need to be adjusted to keep cartography on screen.

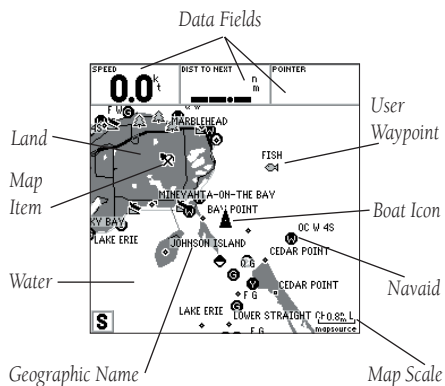

Map Page shown using optional MapSource data.

When the **ARROW KEYPAD** is pressed, the GPSMAP 168 Sounder will enter cursor mode. In cursor mode:

- The cursor can be moved over the map display using the **ARROW KEYPAD**.
- When the cursor nears the edge of the display, the map will scroll forward under the cursor. Keep in mind that the boat icon will move with the map scrolling and may go off the display screen (you may not be able to see your present position).
- When the cursor is stationary, a fixed coordinate position will appear in the position field. Note that the distance and bearing will change as the boat's position changes.
- Whenever you zoom in cursor mode, the cursor will be centered on screen.
- To return to position mode, press the **QUIT** key.



When the cursor reaches the edge of the map, the unit may pause as it loads new map data.

Using the Cursor

The cursor allows you to pan away from your present position and scroll to other map areas around the world (even outside of your current MapSource coverage). As you pan past the edge of the current map display, the screen will actively scroll forward to provide continuous map coverage.

To move the cursor:

1. Press the **ARROW KEYPAD** to move the cursor in an up, down, left or right direction.

As you move the cursor, the distance and bearing from your present position to the cursor will be displayed on the data window, along with the cursor's position coordinates. Keep in mind that when the cursor is stationary, the distance and bearing from your present position will change as your boat moves. The cursor may also be used to "snap to" on-screen waypoints and map items, allowing you to review a selected position directly from the map display.

Reference

Map Page Cursor

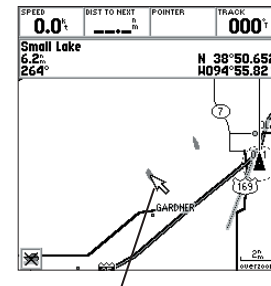

Move the cursor over an item on the map to highlight it.

Map Page Cursor



Pressing ENTER/MARK while highlighting a map item will bring up additional details and options.

To hide the cursor and re-center your position on screen:

1. Press the **QUIT** key.

To select an on-screen waypoint or map item with the cursor:

1. Use the **ARROW KEYPAD** to move the cursor to the desired waypoint or map item (if there are several waypoints grouped closely together, zoom in for a closer view).
2. When a waypoint or map item is selected, it will become highlighted on the screen with the name and position displayed.

With an on-screen waypoint or map item selected, you may review additional details by pushing the **ENTER/MARK** button. If a map item or waypoint includes more than one map feature (like a town, city, intersection, road, lake or river), details for each feature at that location will be displayed in a tabbed format on the Map Feature Review page.

To view information about a map item:

1. Use the **ARROW KEYPAD** to highlight a map item with the cursor and press **ENTER/MARK**. The Map Feature Review page will appear.
2. Use the **ARROW KEYPAD** to view the tabbed information. Each tab shows the name of the map feature, the distance and bearing from your current location, and offers additional options.
3. To center the selected map item on the Map Page, use the **ARROW KEYPAD** to highlight the 'Show on Map' button and press **ENTER/MARK**. The 'Map Feature' page appears with the map feature name, distance and bearing from your current position, and position coordinates. Press **QUIT** once to return to the Map Feature Review page, or press **QUIT** twice to return to the Map Page.
4. To create a waypoint at the selected map location, use the **ARROW KEYPAD** to highlight 'Create Waypt' and press **ENTER/MARK**. The New Waypoint page appears with the name of the map item set as the default waypoint name (see "Creating Waypoints Graphically" on page 49 for more information on creating a waypoint).
5. To return to the Map Page, use the **ARROW KEYPAD** to highlight the 'OK' button and press **ENTER/MARK**, or just press the **QUIT** key.

With MapSource Fishing HotSpots data loaded into the GPSMAP 168 Sounder, additional details are available when you highlight a point on the map within a Fishing Hot Spots coverage area. Fishing Hot Spots data provides detailed information in tabbed format such as shoreline, depth contours, submerged objects, swimming areas, navigational aids, mile markers, boat ramps, marinas, facilities, lake profiles and fishing areas. Lake profiles include details about size, depth, water source, shoreline, bottom conditions and vegetation. Fishing area information describes the area, the type of fish found there, the best time of year to fish that area, and the best types of lures for catching certain fish in that area.

To view Fishing Hot Spots information:

1. Use the **ARROW KEYPAD** to select a map item or map location within the Fishing Hot Spots coverage area and press **ENTER/MARK**.
2. Use the **ARROW KEYPAD** to view the tabbed information pages for that location. Highlight 'OK' and press **ENTER/MARK** when you're finished. You may also select the 'Create Waypt' or 'Show on Map' options the same as with a non-MapSource map item.

To read all the information in a 'Fishing Hot Spots Map' tab:

1. Use the **ARROW KEYPAD** to highlight the text (the entire text field will be highlighted).
2. Press **ENTER/MARK**. A single line of the text field will now be highlighted.
3. Use the **ARROW KEYPAD** to scroll through the text.
4. When you're finished, press **ENTER/MARK**. Use the **ARROW KEYPAD** to view other tabbed information or select other options, or select 'OK' to return to the Map Page.

Reference

Map Page Cursor

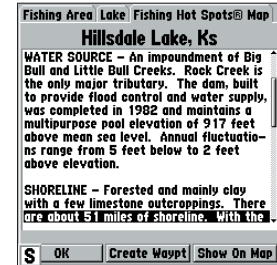

Viewing Fishing Hot Spots information

Map Page Cursor

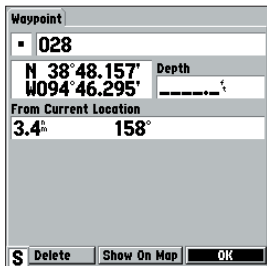

Viewing Waypoint Information

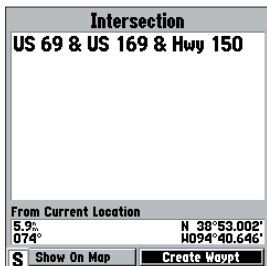

Information Page

To view information about a waypoint:

1. Use the **ARROW KEYPAD** to select a waypoint with the cursor and press **ENTER/MARK**. The Waypoint Review page will appear. If the waypoint is located on a map feature (road, intersection, city, lake, etc.), details about each map feature at that location will be displayed in a tabbed format behind the Waypoint Review Page.
2. From the Waypoint Review Page, you may change the waypoint symbol, name, coordinates, or depth; start a GoTo, Delete the Waypoint or return to the Map Page (see "Reviewing and Editing Waypoints" on page 50 for more information).
3. Use the **ARROW KEYPAD** to view the tabbed Map Feature Information pages. Each tab shows the name of the map feature, the distance and bearing from your current location, and offers additional options.
4. To center the selected map item on the Map Page, use the **ARROW KEYPAD** to highlight the 'Show on Map' button and press **ENTER/MARK**. The 'Map Feature' page appears with the map feature name, distance and bearing from your current position, and position coordinates. Press **QUIT** once to return to the Map Feature Review page, or press **QUIT** twice to return to the Map Page.
5. To create a waypoint from one of the tabbed information pages, use the **ARROW KEYPAD** to highlight 'Create Waypt' and press **ENTER/MARK**. The New Waypoint page appears with the name of the map item set as the default waypoint name (see "Creating Waypoints Graphically" on page 49 for more information on creating a waypoint).
6. To return to the Map Page, use the **ARROW KEYPAD** to highlight the 'OK' button and press **ENTER/MARK**, or press the **QUIT** key.

To create a waypoint with the cursor:

1. Use the **ARROW KEYPAD** to move the cursor to the desired map position.
2. Press and quickly release the **ENTER/MARK** key. The 'New Map Waypoint' page appears.

- To change the waypoint symbol, name or position coordinates, or enter a depth, use the **ARROW KEYPAD** to select the desired field, then press **ENTER/MARK**. Make your changes and press **ENTER/MARK** again to accept the changes.
- When you are finished making changes, or to accept the waypoint using the default 3-digit name and symbol, highlight the 'OK' button and press **ENTER/MARK** to save the new waypoint.

For more information, see "Creating Waypoints" on page 48.

Selecting Map Scales

The map display has 28 available range scales from 20 ft. to 800 mi. (6 mt. to 1200 km). The map scale is controlled by the **IN** and **OUT** keys, with the current scale displayed at the bottom right of the data window.

To select a map scale:

- Press the **OUT** key to zoom out and the **IN** key to zoom in.



The scale value represents the distance from one end of the scale bar to the other.

The GPSMAP 168 Sounder's system has a built-in worldwide database to 20 mi, with more detailed coverage available through the use of the optional MapSource software. The GPSMAP 168 Sounder will display cartography as long as there is chart information available for the range you've selected. Map coverage will conform to the following conditions:

- When the selected zoom range is covered by either the internal database or MapSource data, cartography will be displayed.
- When the selected zoom range is covered by both the internal database and MapSource data, cartography will be displayed using the data with the best resolution.
- When the selected zoom range exceeds the resolution of the data in use, overzoom cartography will be displayed and an 'overzoom' warning will appear below the scale field.

Map Page Cursor and Zooming

New Map Waypoint	
▪ 036	
N 38°48.157'	Depth
W094°44.653'	-----'
From Current Location	
4.1 ⁿ	141°
S Delete Show On Map OK	

Creating a New Map Waypoint



Using Built-In Basemap



Using MapSource Data



Overzoom, no additional data

Map Page Options

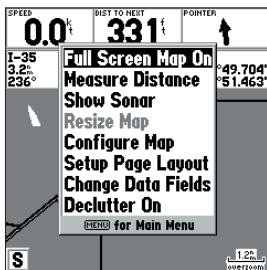

Map Page Options

Map Page Options

Many features of the GPSMAP 168 Sounder are menu driven. Each of the main pages have an options menu, allowing you to custom tailor the corresponding page to your preferences and/or select special features that specifically relate to that page. The data window, located at the top of the main pages (Except the Status Page and Active Route Page), provides a user-selectable layout of various types of useful data. Each data field may be configured to display any one of 27 data options. The data window layout may also be changed to display additional data fields and change the actual size of the data displayed.

The GPSMAP 168 Sounder's Map Page provides access to functions and features relating to the Map Page and the layout options.

To display the Map Page options:

1. Press **MENU**.

To select a menu option:

1. Use the **ARROW KEYPAD** to highlight the desired option and press **ENTER/MARK**.

The available options are Full Screen Map On/Full Screen Map Off, Measure Distance, Show Sonar/Show Flasher/Hide Flasher, Resize Map, Configure Map, Setup Page Layout, Change Data Fields and Declutter On/Off. Following are details on using each of these options.

- **Full Screen Map On/Full Screen Map Off** — toggles between a Map Page without or with data fields on the map display.

To maximize the map/show data fields:

1. Highlight the 'Full Screen Map On' option and press **ENTER/MARK**. The Map Page will now be maximized with no data fields.
2. To show the data fields again, press **MENU**, highlight 'Full Screen Map Off' and press **ENTER/MARK**.

• **Measure Distance**— allows you to measure the bearing and distance between any two points on the map display.

To measure the BRG/DIS between two points:

1. Highlight the 'Measure Distance' option and press **ENTER/MARK**. An on-screen pointer will appear on the map display at your present position with 'ENT REF' below it.
2. Move the cursor to the desired reference point (the point that you want to measure from) and press **ENTER/MARK**.
3. Move the cursor to the point that you want to measure to. The bearing and distance from the reference point will be displayed in the data window at the top of the display.
4. Press the **QUIT** key to finish.

• **Show Sonar/Show Flasher/Hide Flasher**— toggles a split screen showing Sonar or Flasher information on the right side of the Map Page in addition to the map. With 'Show Sonar' active, the unit will act as a fishfinder showing a graphic representation of fish, water depth, thermoclines and structure, and bottom type and shape. In 'Show Flasher' mode, the graphic Flasher displays structure and bottom returns much the same as a true Flasher.

To cycle through the 'Show Sonar/Show Flasher/Hide Flasher' options:

1. From the Map Page press **MENU**.
2. Using the **ARROW KEYPAD**, highlight 'Show Sonar', 'Show Flasher', or 'Hide Flasher'.
3. Press **ENTER/MARK** repeatedly to cycle through the options. You will see the Sonar or Flasher information appear on the screen behind the menu window on the right side of the display.
4. Press **QUIT** when you have the desired setting to return to the Map Page.

Reference

Map Page Options

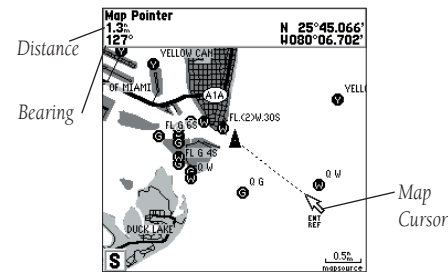

Full Screen Map Shown

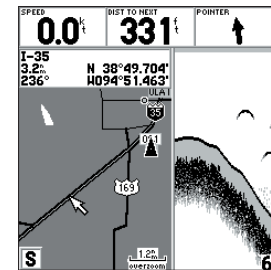

Map Page with Sonar information shown

Reference

Map Page Options

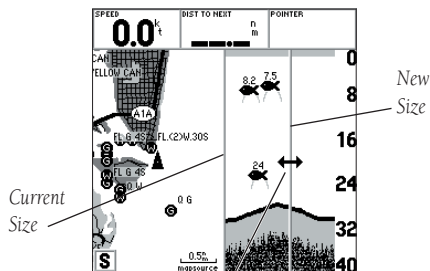

Move the double arrow left or right to adjust the size of the Sonar or Flasher window.

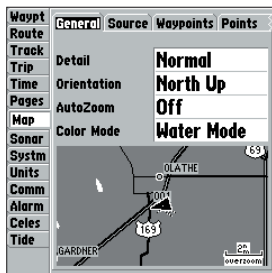

Main Menu—Map Configuration Tab

- **Resize Map**— enables width adjustment of the Map and Sonar/Flasher split screen. This option is only available when the unit is in ‘Show Sonar’ or ‘Show Flasher’ mode. You may adjust the size of the Sonar/Flasher window anywhere from 1/3 to 1/2 width of the right half of the Map Page.

To resize the Map Page split screen:

1. From the Map Page and Sonar/Flasher split screen, press **MENU**.
2. Using the **ARROW KEYPAD**, highlight ‘Resize Map’ and press **ENTER/MARK**.
3. Move the horizontal double-arrow LEFT or RIGHT using the **ARROW KEYPAD** until the desired vertical width line shows, then press **ENTER/MARK**.
4. If you wish to cancel this operation, press **QUIT** or press **MENU**, highlight ‘Stop Resizing’ and press **ENTER/MARK**.

- **Configure Map**— allows you to configure the map display to your preferences, including map detail, map orientation, automatic zoom, and various map items and points. The map configuration option uses a ‘file tab’ feature, making it easier to organize the various settings for ease of use. The following table lists the file tabs and the settings available under each tab:

General	Detail, Orientation, AutoZoom
Source	Basemap, MapSource
Waypoints	Waypoints, Active Route
Points	Spot Soundings, Tide Stations, Services, Nav aids
Nav Line	Heading Line, Bearing Line, Course Line
Track	Saved Tracks, Track log
Geo	Geo Points, Rivers/Lakes, Park Areas
Topo	Major/Medium/Minor Contours, Land Cover
Other	Accuracy Circle, Lat/Lon Grid, Map Outlines

Map Page Options

To change a map setup feature:

1. From the Map Page menu, highlight 'Configure Map' and press **ENTER/MARK**.
2. Move LEFT or RIGHT on the **ARROW KEYPAD** to highlight the desired tab, then UP or DOWN on the **ARROW KEYPAD** to highlight to the setting you want to change and press **ENTER/MARK**.
3. Move UP or DOWN on the **ARROW KEYPAD** to highlight to the desired setting and press **ENTER/MARK**.
4. To exit, press **QUIT**.

Map Configuration Tabs

The Waypoints, Points, Track, Geo, and Topo Tabs have settings for either 'Text', 'Zoom' or both. Below is a description for each setting and how it will affect the Map Page.

Text— None, Small, Medium, and Large: controls the screen size of the name.

Zoom— Auto, Off, 20 ft.-800 mi.: sets the maximum scale at which the feature should appear on the screen. Some types of data will only show up to certain zoom scales.

General Tab

Detail— Most, More, Normal, Less, Least: controls how much map detail you will see. This setting only applies to any map feature set to "Auto". Those features which have a specified scale or turned "Off" are unaffected by this setting.

Orientation— North Up— fixes the top of the map display to a north heading; Track Up— fixes the top of the map display to the current track heading; Course Up— fixes the map so the direction of navigation is always "up" and turns the navigation leg line vertical on the screen.

AutoZoom— On/Off: when "On" the map will automatically adjust the map scale to a lower scale as you approach you destination point.

Color Mode— Water Mode, Land Mode: when in "Water Mode", land will appear as a dark color and water will be light. In "Land Mode", land will appear as a light color and water will be dark.

Source Tab

Basemap— On/Off: turns the built in base map on or off.

MapSource— On/Off: turns the optional MapSource data loaded in the unit on or off.

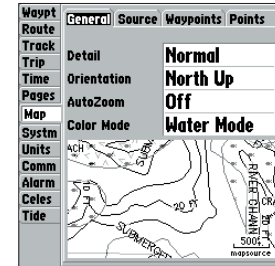

Main Menu— Map Configuration Tab

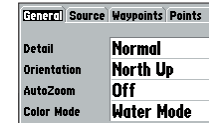

General Tab

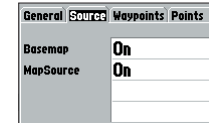

Source Tab

Reference

Map Page Options

Waypoints	Points	Nav Line	Track
Text		Zoom	
Waypoints	Medium	AUTO	
Active Route	Medium	AUTO	

Waypoints Tab

Spot Soundings	Tide Stations	Services	Nav aids
Text		Zoom	
Spot Soundings	Small	On	
Tide Stations	None	AUTO	
Services	None	AUTO	
Nav aids	Medium		

Points Tab

Heading Line	Bearing Line	Course Line
Text		Zoom
Heading Line	On	
Bearing Line	AUTO	
Course Line	AUTO	

Nav Line Tab

Saved Tracks	Track Log	
Text		Zoom
Saved Tracks		AUTO
Track Log		AUTO

Track Tab

Geo Points	Rivers, Lakes	Park Areas
Text		Zoom
Geo Points	Medium	AUTO
Rivers, Lakes	Medium	AUTO
Park Areas	Medium	AUTO

Geo Tab

Major Contour	Medium Contour	Minor Contour	Land Cover
Text		Zoom	
Major Contour	Medium	AUTO	
Medium Contour	Medium	AUTO	
Minor Contour	Small	AUTO	
Land Cover	Medium	AUTO	

Topo Tab

Accuracy Circle	Lat/Lon Grid	Map Outlines
Text		Zoom
Accuracy Circle	On	
Lat/Lon Grid	Medium	OFF
Map Outlines		On

Other Tab

Waypoints Tab— Waypoints, Active Route

Text and Zoom settings, see the description on page 33 for details.

Points Tab— Spot Soundings, Tide Stations, Services, Nav aids

Text and Zoom settings, see the description on page 33 for details.

Nav Line Tab

Heading Line— On/Off: turns the Heading Line on or off. The Heading Line projects from the triangle showing your current heading.

Bearing Line— Auto, Off, 20 ft-800 mi: sets the maximum scale at which the Bearing Line should appear on the screen. The Bearing Line shows the bearing from your current location to a destination waypoint.

Course Line— Auto, Off, 20 ft-800 mi: sets the maximum scale at which the Course Line should appear on the screen. The Course Line shows a direct navigation line from the point navigation was initiated to a destination waypoint.

Track Tab— Saved Tracks, Track Log

Zoom setting, see the description on page 33 for details.

Geo Tab— Geo Points, Rivers/Lakes, Park Areas

Text and Zoom settings, see the description on page 33 for details.

Topo Tab— Major/Medium/Minor Contours, Land Cover

Text and Zoom settings, see the description on page 33 for details.

Other Tab

Accuracy Circle— On/Off: toggles the circle “On” and “Off”. The circle represents the approximate accuracy of the unit based on EPE, DOP, and basemap quality. You position will be within the circle.

Lat/Lon Grid—Text and Zoom settings determine when the grid and labels will be displayed on the Map Page. See the description for the Text and Zoom settings on page 33 for details.

Map Outlines—On/Off toggles the outline showing areas of MapSource Data that are loaded in the unit.

Map Setup Menu Options

From the map setup page, you can access the following menu options:

- Restore Defaults— restores settings back to factory settings for the tab highlighted.
- Restore All Map Defaults— restores settings back to factory settings for all tabs.
- MapSource Info— allows you to display/not display optional map sets loaded in the unit.

To restore defaults for map settings:

1. From the Map tab in the Main Menu, highlight the Map Configuration tab that you want to restore to the factory default settings, and press **MENU**.
2. Highlight 'Restore Defaults' (highlight 'Restore All Map Defaults' if you want all tabs restored) and press **ENTER/MARK**.

MapSource Info— shows the number of maps downloaded from the optional MapSource software package. Each downloaded map is described by name, and may be deselected if you wish to retain the map in memory, but not display the data on the Map Page.

To display the MapSource Info Page:

1. From the Map tab, press **MENU** then highlight 'MapSource Info' and press **ENTER/MARK**.
2. Use the **ARROW KEYPAD** to scroll through the list of downloaded maps.
3. To select/deselect a map, highlight the name of the desired map. Press **ENTER/MARK** to select/deselect the map. The map is selected and will be displayed on the Map Page when a "✓" appears in the box adjacent to that map. You may also press **MENU** and choose to 'Show All' or 'Show None' and press **ENTER/MARK**.

• **Setup Page Layout**— allows you to change the text size and number of data fields that will be displayed. The following options are available:

- None— No data fields will be displayed
- Small (1 Row) Small text, 4 data fields
- Small (2 Rows) Small text, 8 data fields
- Small (3 Rows) Small text, 12 data fields
- Medium (1 Row) Medium text, 3 data fields
- Medium (2 Rows) Medium text, 6 data fields
- Large (1 Row) Large text, 1 data field
- Huge (1 Row) Huge text 1 data field
- Huge (2 Rows)* Huge text with a compass ribbon at the bottom of the display, 2 data fields

* This option is available only on the Compass Page.

Reference

Map Page Options



Map Setup Menu Options

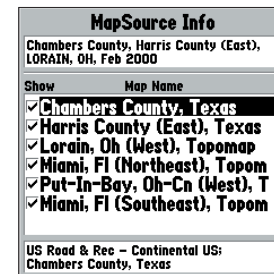

MapSource Info Page

Reference

Map Page Options

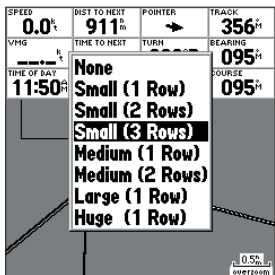

Choose the size and number of data fields you wish to display.

To change the page layout:

1. From the menu, use the **ARROW KEYPAD** to highlight the 'Setup Page Layout' option and press **ENTER/MARK**.
2. Move up or down on the **ARROW KEYPAD** to highlight to the desired setting and press **ENTER/MARK**. To exit, press **QUIT**.

• **Change Data Fields** — allows you to specify the type of data displayed in each data field used on the map display.

The following options are available for Map page data fields (and on the Highway and Compass pages):

- BEARING – Compass direction from your position to destination
- COURSE – Course over ground
- DEPTH – Depth below transducer (only available with additional sonar NMEA data)
- DIST TO DEST – Distance to final waypoint
- DIST TO NEXT – Distance to next waypoint
- ETA AT DEST – Estimated Time of Arrival to final waypoint
- ETA AT NEXT – Estimated Time of Arrival to next waypoint
- ELEVATION – Elevation above/below MSL (Mean Sea Level)
- MAX SPEED – Fastest speed the unit has traveled
- MOV AVG SPEED – Average moving speed
- MOV TRIP TIMER – Time unit has been moving for a trip
- OFF COURSE – Distance from desired track
- POINTER – Arrow points to your destination
- SPEED – Speed over ground/water
- TIME OF DAY – Current time
- TIME TO DEST – Time to final waypoint at current speed and course
- TIME TO NEXT – Time to next waypoint at current speed and course

continued

Data Field Options continued

- TO COURSE – Distance to desired track
- TRACK – Current compass heading
- TRIP ODOM – Trip Odometer
- TTL AVG SPEED – Total average speed
- TTL TRIP TIMER – Total travel time of trip, stopped and moving
- TURN – Turn angle to waypoint
- VMG – Velocity Made Good to destination
- WATER SPEED – Speed through the water (only available with additional sonar NMEA data)
- WATER TEMP – Water temperature (only available with additional sonar NMEA data)

To change a data field:

1. From the menu, use the **ARROW KEYPAD** to highlight the 'Change Data Fields' option and press **ENTER/MARK**.
2. Move the field highlight to the data field you want to change and press **ENTER/MARK**.
3. Move up or down on the **ARROW KEYPAD** to highlight the data you want to display, and press **ENTER/MARK**. To exit, press QUIT.

Map Page Options

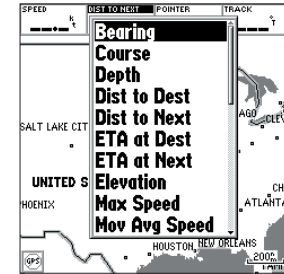

Choose the type of data you wish to display for each field.

Reference

Sonar Page

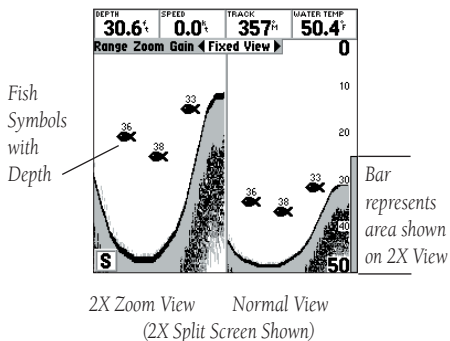
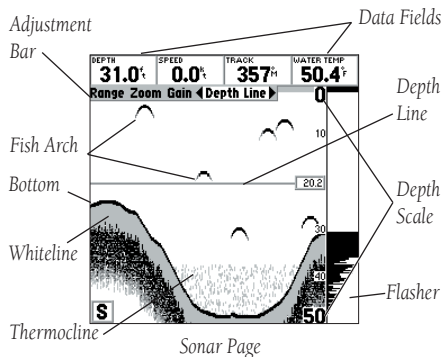

Sonar Page

The Sonar Page is where your GPSMAP 168 Sounder becomes a powerful fishfinder/flasher. The top of the screen contains data fields which can display any of 27 selectable data field options, while the Adjustment Bar below the data fields allows direct access to the settings most commonly changed while using the Sonar Page. These include the depth 'Range', 'Zoom' setting, 'Gain' (sensitivity) and 'View' (zoom mode only) of the unit. The middle of the page contains a right-to-left moving sonar image of the water beneath your boat. (Note: Items appear as they pass under your transducer. Those items on the right side of the screen are closer to you than those on the left.) Along the right side of the screen is an adjustable scale which reflects the depth of the area being displayed.

Fish are displayed as a darkened arch or a fish icon in three different sizes. Thermoclines are shown as shades of gray. The area of strongest sonar return (or whiteline) is displayed as solid gray. Typically, the bottom will be the primary whiteline. A thin whiteline indicates a soft bottom while a thick whiteline shows a harder bottom. A black line is used to show the point where the water meets the whiteline. This black line will follow the contour of the bottom and show any objects of reasonable size. For more information on understanding sonar and the display, see Appendix H.

Using the Adjustment Bar

The Adjustment Bar allows direct access to the settings most commonly changed while using the unit. These include the depth 'Range', 'Zoom' setting, the 'Gain' (sensitivity), 'View' adjustment, and 'Line' (Depth Line) of the unit. The 'View' setting will only display when the Sonar Page is in split screen mode. The 'Line' setting will appear only when the Depth Line is activated.

To select a setting from the Adjustment Bar:

1. Using the **ARROW KEYPAD**, place the highlight (white bar) over the desired selection by pressing RIGHT or LEFT on the **ARROW KEYPAD** and the current setting will be displayed in the highlight. If you wish to review the available settings before making a change, press **ENTER/MARK** to activate the adjustment list. To immediately change the setting, press UP or DOWN on the **ARROW KEYPAD**.

Sonar Page

- With the **ARROW KEYPAD**, move UP or DOWN and place the pointer or adjustment bar at the desired setting or range.
- To change 'View' to 'Auto' or 'Line' to 'Off', hold UP or DOWN on the **ARROW KEYPAD** until the adjustment bar reaches the top or bottom of the scale, release, then press once more in the same direction.
- You may press **QUIT** or **ENTER/MARK** to accept the setting and return to the Sonar Page. You may also press RIGHT or LEFT on the **ARROW KEYPAD** to accept the setting and move to the next Adjustment Bar setting.

The available Adjustment Bar options are:

- Range**— sets the display depth range used for viewing. The unit can be set to automatically track the bottom or set to a user-specified depth range.
- Zoom**— used to quickly select a display zoom scale or to split the display. When a scale other than 'No Zoom' is selected, the Adjustment Bar will display a new selection labeled View. See page 15 for a detailed description of the available Zoom settings.
- Gain**— allows the user to control the sensitivity of the unit's receiver. This provides some flexibility in what is seen on the display. To see more detail, increase the receiver sensitivity by selecting a higher gain (+). If there is too much detail or if the screen is cluttered, lowering the sensitivity (-) may increase the clarity of the display.
- View**— available when a Zoom scale other than 'No Zoom' is selected. The 'View' setting is used to change the viewing range of a zoomed display. If the display is split, only the zoomed portion on the left side of the display will be affected by the change.
- Depth Line**— the Depth Line setting is only available if 'Depth Line' is selected from the Sonar Page Options. See Page 41 for detailed instruction on the Depth Line.



If the unit is unable to track the bottom for any reason, the digits in the depth window will flash on and off to alert the user that the unit is not tracking the bottom.

Range Adjustment

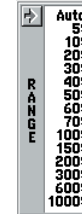

Range Adjustment

Zoom Adjustment



Zoom Adjustment

Gain Adjustment

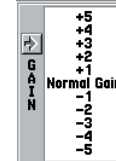

Gain Adjustment

Zoom View Adjustment

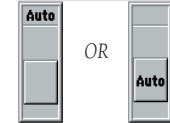

Manual Mode OR Auto Mode

Depth Line Adjustment

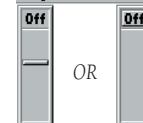

Depth Line Adjustment

(Off Selected)

Reference

Sonar Page Options

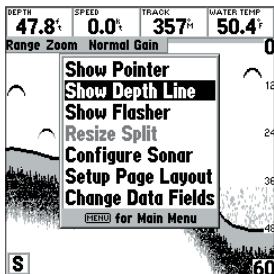

Sonar Page Options Menu

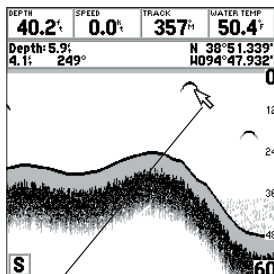

Use the **ARROW KEYPAD** to point to an underwater target.

Sonar Page Options

The GPSMAP 168 Sounder's Sonar Page features a menu page that provides access to additional functions and to layout and data field options.

To display the Sonar Page options:

1. Press **MENU**.

To select a menu option:

1. Use the **ARROW KEYPAD** to highlight the desired option and press **ENTER/MARK**.

The following options are available:

- **Show/Hide Pointer**— allows you to reference sonar items and mark underwater waypoints. This makes it easier to find and use an object such as a stump for a future fishing location. When using this feature, the Sonar Page will pause. The pointer will not move off the paused display and cannot show an area that has scrolled off the screen. The depth will continue to update while the display is paused, but the unit will not show any new sonar data until the standard Sonar Page is resumed. You may see a discontinuity from where the sonar information stops to where it starts again.

To mark an underwater waypoint:

1. From the Sonar Page, press **MENU**, highlight 'Show Pointer' and press **ENTER/MARK** to pause the screen movement.
2. Use the **ARROW KEYPAD** to move the cursor onto the target (underwater drop off, stump, etc.) you want to mark. A data field will appear with the cursor's depth, coordinates, and bearing and distance from your current position.
3. Press **ENTER/MARK**. The New Map Waypoint page will appear with the waypoint's coordinates, default three-digit name, and depth automatically filled in.
4. To change the name, symbol or depth, highlight the appropriate field and press **ENTER/MARK**. Make your changes and press **ENTER/MARK** when done.
5. When done, move the field highlight back to the 'OK' prompt and press **ENTER/MARK**.
6. To return to the standard Sonar Page, press **QUIT** or press **MENU**, highlight 'Hide Pointer' and press **ENTER/MARK**.

- **Show/Hide Depth Line**— adds the 'Depth Line' selection to the Adjustment Bar and a horizontal depth line across the display which is used to measure the depth of underwater objects. The depth of the line will appear in a box on the right side of the line.

To activate/deactivate the Depth Line from the Sonar Page:

1. Press **MENU** to display the Sonar Page options.
2. Using the **ARROW KEYPAD**, highlight 'Show/Hide Depth Line' and press **ENTER/MARK**.

To change the position of the Depth Line:

1. Highlight the 'Depth Line' selection on the Adjustment Bar, then press UP or DOWN on the **ARROW KEYPAD** to control the position of the line on the chart. The depth is displayed in a window on the right side of the line.

- **Show/Hide Flasher**— with the 'Flasher' active, a graphic Flasher representation will be displayed on the far right side of the chart. This graphic Flasher displays structure and bottom returns much the same as a true Flasher. You may find this feature particularly useful when using 'Fish Symbols'.

To turn the Graphic Flasher on and off:

1. From the Sonar Page menu, highlight 'Show/Hide Flasher' and press **ENTER/MARK**.

- **Resize Split**— enables width adjustment of the Sonar split screen. This option is only available when a zoom scale other than 'No Zoom' is selected. You may adjust the size of the split window anywhere from 1/4 to 3/4 width of the Sonar Page.

To resize the Map Page split screen:

1. From the Map Page and Sonar/Flasher split screen, press **MENU**.
2. Using the **ARROW KEYPAD**, highlight 'Resize Map' and press **ENTER/MARK**.
3. Move the horizontal double-arrow LEFT or RIGHT using the **ARROW KEYPAD** until the desired vertical width line shows, then press **ENTER/MARK**.
4. If you wish to cancel this operation, press **QUIT** or press **MENU**, highlight 'Stop Resizing' and press **ENTER/MARK**.

Reference

Sonar Page Options

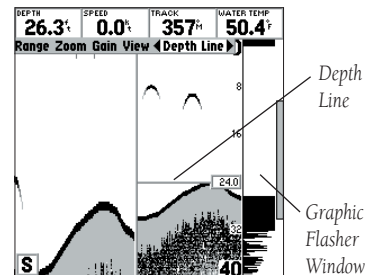

2X Zoom Split Screen

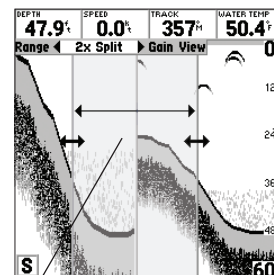

You may resize the split line to the left or right anywhere within the shaded region.

Reference

Sonar Tab Options

Waypt	Fish Symbols	Whiteline
Route	Off	On
Track		
Trip	Scroll Speed	Scale
Time	Fast	Overlay
Pages	Noise Reject	Water Type
Map	Auto	Fresh
Sonar	Keel Offset	Remember
System	0.0'	Setup Only
Units		
Comm		
Alarm	Calibrate Water Speed	
Ceas		
Tide		

Sonar Menu Tab Options

Off

Fish Symbols Off— All available information will be displayed.



Suspended targets will display as fish symbols. Background information will be displayed.



Same as above with the target depth attached.



Suspended targets display as fish symbols. No background information will be displayed.



Same as above with target depth attached.

• **Configure Sonar**— contains the unit settings that should not require frequent change. The Sonar setup menu contains settings for Fish Symbols, Whiteline, Scroll Speed, Scale, Noise Reject, Keel Offset, Water Type, Remember, and Calibration.

To enter the Sonar setup menu, press the **MENU** key from the Sonar Page, highlight 'Configure Sonar' and press **ENTER/MARK**. You may also press **MENU** twice from any screen, then highlight the 'Sonar' tab using the **ARROW KEYPAD**. Press the RIGHT arrow to access the selection fields. Each time the Setup Menu is accessed, the unit will return to the last edited selection field.

To change a setting on the Sonar tab:

1. Using the **ARROW KEYPAD**, highlight the desired field and press **ENTER/MARK** and the available options will appear.
2. Highlight the desired setting and press **ENTER/MARK**.
3. Press **QUIT** to return to the Sonar Page or previous page.

The available Sonar tab options are:

- **Fish Symbols**— allows the user to determine how the chart will display underwater targets and background information. If Fish Symbols are set to 'Off', the unit will display all of the available information about the underwater environment. If a fish symbol is selected, the chart will display only the information related to that symbol.
- **Whiteline**— controls how the unit displays information about the bottom type (hard or soft). With the Whiteline 'Off', the bottom return will display as black and contain no information on bottom hardness. With Whiteline 'On', the bottom return will become grayscaled and can be used to determine bottom hardness. See page 38 for more detail on this feature.
- **Scroll Speed**— adjusts the speed that the chart scrolls from right to left. If you are sitting still or the chart is moving too fast, slowing the scroll rate can be beneficial. Options are 'Fast', 'Medium', 'Slow' or 'Pause'.



If you are using the GPSMAP 168 Sounder on the portable case battery power, slowing the scroll rate will help to conserve your battery.

Sonar Tab Options

Transducer at Surface

Enter (+) positive number to show depth from bottom of keel

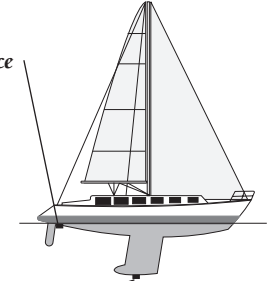
**Transducer at Bottom of Keel**

Enter (-) negative number to show depth from surface



When setting the Noise Reject tool: the HIGHER the noise rejection setting, the unit is more likely to NOT show fish or structure.

- **Keel Offset**— allows the user to offset the surface reading for the depth of a keel. This makes it possible to measure depth from the bottom of your keel instead of from the transducer's location. Enter a positive number to offset for a keel. It is also possible to enter a negative number to compensate for a large vessel that may draw several feet of water. The 'Keel Offset' will be reflected in the depth reading.
- **Water Type**— since sound waves travel through 'Fresh' and 'Salt' water at different rates it is necessary to select the 'Water Type' to ensure accurate readings on the unit.
- **Remember**— the unit can be set to remember 'All' of the Sonar settings including the Adjustment Bar (even after it has been powered off and back on), or just the 'Setup Only' items on the Sonar tab.
- **Calibrate Water Speed**— this is only available if you are using a speed-capable transducer. Calibration is required to ensure that the Water Speed displayed on your unit will be accurate. The unit will automatically use the GPS ground speed, if it is available, for comparison on the calibration. If a GPS ground speed is not available, use either your boat's speedometer reading (not always accurate) or a stopwatch to determine your speed over a certain distance (distance / time = speed). It is recommended that the calibration take place in water having little or no current.

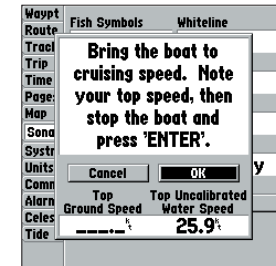

Calibrating the Speed Sensor

Sonar Tab Options

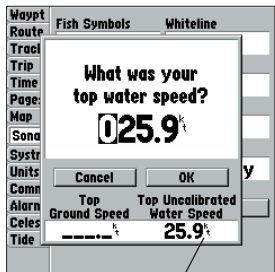

If a ground speed is not available, the unit will use the uncalibrated water speed.



An error message will appear if the speed sensor is not working or not installed.

To calibrate the water speed:

1. From the 'Sonar' tab, use the **ARROW KEYPAD** to highlight 'Calibrate Water Speed' and press **ENTER/MARK**.
2. Bring the boat to a cruising speed. Both the top ground and uncalibrated water speeds will be shown at the bottom of the calibration window. Note your top speed, then stop the boat and press **ENTER/MARK**.
3. By default, the top ground speed will automatically show in the 'What was your top water speed?' field. If a ground speed is not available, the top uncalibrated water speed will be used instead. If the new speed is correct, highlight 'OK' and press **ENTER/MARK**. If you wish to manually enter a calibration, press **ENTER/MARK** on the speed field, enter a new speed and press **ENTER/MARK**.
4. You may also press **MENU** from the calibration screen and choose 'Use Top Ground Speed' to default back to ground speed or 'Use No Calibration' to use the speed sensor's uncalibrated speed.



If the boat is not moving fast enough or the speed sensor is not outputting a speed, you will see a "Boat Is Not Moving Fast Enough To Calibrate" message at the bottom of the display. Check that the speed sensor wheel is moving or safely increase boat speed.



If there is a problem with the speed sensor/unit or if a speed sensor is not installed, a "Water Speed Sensor Is Not Working" message will appear at the bottom of the display. Check connections of speed sensor cables.

- **Setup Page Layout**— allows you to change the text size and number of data fields that will be displayed.
- **Change Data Fields**— allows you to specify the type of data displayed in each data field used on the map display.

For detailed instructions on changing the data fields and layout of the Sonar Page, see page 35-37.

Compass Page

The GPSMAP 168 Sounder features two different navigation pages: Compass and Highway. Whenever a **NAV/MOB**, Follow Track (TracBack) or Follow Route have been activated, the GPSMAP 168 Sounder's Compass Page will guide you to your destination with digital readouts and a graphic compass display, which includes a bearing pointer. Use this page (instead of the Highway Page) when travelling at slower speeds, when making frequent directional changes, or where straight-line navigation is not possible due to obstructions or terrain. The middle of the page features a rotating 'compass ring' that shows your course over ground (track) while you're moving. Your present course over ground is indicated at the top of the compass ring. A bearing pointer, in the middle of the compass ring, indicates the direction of the destination (bearing) relative to the course over ground. The compass ring and pointer arrow work independently to show—at a glance—the direction of your movement and the direction to your destination. For instance, if the arrow points up, you are going directly to the waypoint. If the arrow points any direction other than up, turn toward the arrow until it points up, then continue in that direction.

The GPSMAP 168 Sounder's Compass Page features a menu page that provides access to layout and data field options. The data window, located at the top of the page, provides a user-selectable layout of various types of useful data. Each data field may be configured to display any one of 27 data options. The data window layout may also be changed to display additional data fields and change the actual size of the data displayed.

To display the Compass Page options:

1. Press **MENU**.

To select a menu option:

1. Use the **ARROW KEYPAD** to highlight the desired option and press **ENTER/MARK**. For detailed instructions on changing the data fields and layout of the Compass Page, see pages 35-37.

Reference

Compass Page

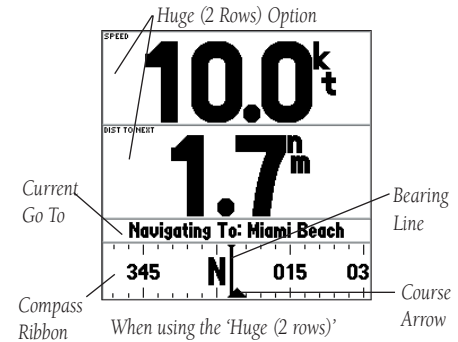
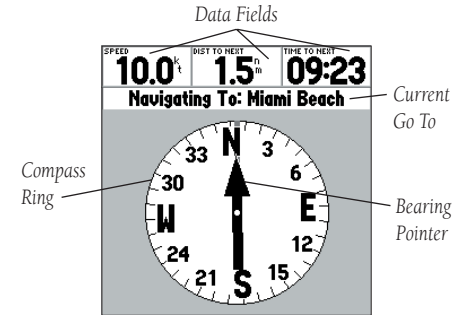

When using the 'Huge (2 rows)' option, steer until the bearing line is aligned with the course arrow.

Reference

Highway Page

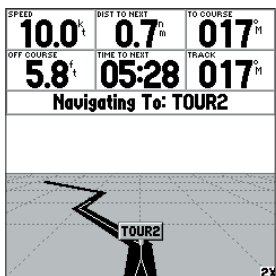
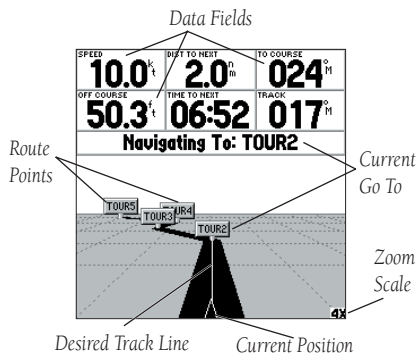

You can configure the page to show the active point only and also zoom out to get a better view.

Highway Page

Whenever a **NAV/MOB**, TracBack or route has been activated, the GPSMAP 168 Sounder's Highway Page will provide digital and graphic steering guidance to the destination with the Navigation Page. The top half of the Highway Page features user-selectable data fields that display useful navigation data. The bottom half of the screen provides visual guidance to the waypoint on a graphic highway display. The line down the center of the highway represents your desired track line.

As you head toward your destination, the highway perspective moves to indicate your progress to the waypoint and which direction you should steer to stay on course. If you are navigating a route, the Highway Page shows each route waypoint in sequence connected by a black "road" with a white line down the middle, which is your desired track line. Nearby waypoints not in the active route can also be displayed. The highway perspective scale may also be zoomed in or out to display a larger or smaller view of the highway. Five settings are available from 1X to 16X, with a default setting of 8X.

To change the highway perspective scale:

1. Press the **IN** or **OUT** key to select the desired setting.

The GPSMAP 168 Sounder's Highway options page allows you to define the data fields and select which waypoints are displayed on screen. The data window, located at the top of the page, provides a user-selectable layout of various types of useful data. Each data field may be configured to display any one of 27 data options. The data window layout may also be changed to display additional data fields and change the actual size of the data displayed.

The GPSMAP 168 Sounder's Highway Page features a menu options page that provides access to functions and features relating to the Highway Page and the layout options.

To display the Highway Page options:

1. Press **MENU**.

To select a menu option:

1. Using the **ARROW KEYPAD**, highlight the desired option and press **ENTER/MARK**.

Highway Page Options



Highway Page Options Menu

The following options are available from the Highway Page menu:

- **Show/Hide Tracks**— toggles the display of track lines on/off.
- **Configure Highway**— allows you to select what waypoints are shown on the Highway display. Four options are available:
 - Rte & Nearest— all route and nearest waypoints displayed.
 - Route Only— only waypoints in the route will be displayed.
 - Active Only— only the active waypoint will be displayed.
 - Hide All— no waypoints will be displayed.

To configure the highway display:

1. From the menu, highlight 'Configure Highway' and press **ENTER/MARK**.
2. Highlight the desired option and press **ENTER/MARK**.

- **Setup Page Layout**— allows you to change the text size and number of data fields that will be displayed.
- **Change Data Fields**— allows you to specify the type of data displayed in each data field used on the map display.

For detailed instructions on changing the data fields and layout of the Highway page, see pages 35-37.

Active Route Page

Whenever you have activated a route in the GPSMAP 168 Sounder's system, the Active Route page will show each waypoint of the active route, along with various, user-selectable types of data. For additional details on the Active Route Page, see page 68.

Route Name

Route Points

Active Route		
GPSMAP TOUR		
Waypoint	Distance	Course
TOUR1	---	003°
TOUR2	1.8 ⁿ	330°
TOUR3	4.4 ⁿ	001°
TOUR4	7.5 ⁿ	325°
TOUR5	17.3 ⁿ	---

TOTALS	17.3ⁿ	337°

Selectable Data Field

Reference

Creating Waypoints

The screenshot shows the 'New Waypoint' screen with the following fields and values:

New Waypoint	
002	
N 38°51.338'	Depth
W094°47.929'	-----'
From Current Location	
0.0'	000°
S Delete Show On Map OK	

Press **ENTER/MARK** to use the default name and symbol.

The screenshot shows the 'New Waypoint' screen with the name field highlighted. The fields and values are the same as in the previous screenshot, but the name field '002' is highlighted.

New Waypoint	
002	
N 38°51.338'	Depth
W094°47.929'	-----'
From Current Location	
0.0'	000°
S Delete Show On Map OK	

Highlight a field and press **ENTER/MARK** to enter a new symbol, name or depth.

Creating and Using Waypoints

The GARMIN GPSMAP 168 Sounder stores up to 500 alphanumeric waypoints with a user-defined icon and depth available for each waypoint. Waypoints can be created using three basic methods:

- **ENTER/MARK** key– used primarily for marking your present position, the **ENTER/MARK** key also provides options that allow you to select a map position or map item from the map display.
- Graphically– allows you to define a new waypoint position from the map display using the **ARROW KEYPAD**.
- Text Entry– allows you to enter a new waypoint's position coordinates manually.

ENTER/MARK Key

The GARMIN GPSMAP 168 Sounder's **ENTER/MARK** key lets you quickly capture your present position— or cursor or map item position— in order to create a new waypoint. You must have a valid position (2D or 3D) fix to mark your present position. This can be determined by looking at the Status Page. When you move the cursor over a map item, you will see a highlighted description of that item.

To mark your present position:

1. Press and hold the **ENTER/MARK** key until the 'New Waypoint' window appears then release it. You will see a default three-digit name and symbol for the new waypoint.
2. To accept the waypoint with the default name and symbol, press **ENTER/MARK** to confirm the highlighted 'OK' prompt.
3. To enter a different name, highlight the name field and press the **ENTER/MARK** key, then use the **ARROW KEYPAD** to enter the new letter/numbers and press **ENTER/MARK** when done. Note: You may use up to 10 alphanumeric characters for the name.
4. To enter a different symbol, highlight the symbol field to the left of the name and press the **ENTER/MARK** key, then use the **ARROW KEYPAD** to highlight the new symbol and press **ENTER/MARK**.

- To enter an optional depth, highlight the "Depth" field to the right of the position coordinates and press the **ENTER/MARK** key, then use the **ARROW KEYPAD** to enter a value and press **ENTER/MARK**.
- When done, use the **ARROW KEYPAD** to highlight the 'OK' prompt and press **ENTER/MARK** to save the waypoint into memory.

Creating Waypoints Graphically

Waypoints may also be quickly created using the map display. This feature allows you to select any map position with the cursor and create a new waypoint. To mark a map item, select the desired map item with the cursor then press and release the **ENTER/MARK** key. If you select an item on the map, like a city, the GPSMAP 168 Sounder will use the text or name shown on the cartography as the default name. When selecting a map item, the option 'Create Waypoint' will appear in addition to a description of that point and its distance and bearing from your current position.

To create a new waypoint graphically:

- Use the **ARROW KEYPAD** to move the cursor to the desired map position. If you want to create the new waypoint at an on-screen map item, highlight the map item on the map display.
- Press and quickly release the **ENTER/MARK** key. The 'New Map Waypoint' page appears. (NOTE: Pressing and holding the **ENTER/MARK** key will mark your current location instead of the cursor location, and bring up the 'New Waypoint' page)

If you are using a map item to create a waypoint, an information page(s) for the map item will appear first. Use the **ARROW KEYPAD** to highlight 'Create Waypt' and press **ENTER/MARK**. The 'New Waypoint' page will now appear.

- To accept the waypoint with the default name and symbol, press **ENTER/MARK**. If you are creating a waypoint from an on-screen map item, the name and symbol will automatically reflect the selected map item's name and symbol.
- To change the name, symbol or enter a depth, highlight the appropriate field and press **ENTER/MARK**. Make your changes and press **ENTER/MARK** when done.
- After entering and confirming your changes, highlight 'OK' and press **ENTER/MARK**.

Creating Waypoints

New Map Waypoint	
003	
N 38°51.142'	Depth
W 094°47.472'	
From Current Location	
0.4 ⁿ	119°
S Delete Show On Map OK	

Map waypoint from non-map item.

Large City Large City	
Miami	
From Current Location	
1074.8 ⁿ	N 25°50.391'
132°	W 080°09.375'
S Show On Map Create Waypt	

Choose 'Create Waypt' to use a map item for a new waypoint.

Reference

Creating and Editing Waypoints

Symbol

Coordinates

Name

Depth

003

N 38°51.338' W 094°47.929'

From Current Location 0.0 000°

Delete Show On Map OK

New Waypoint Page

Map Feature Info Tab

005

N 38°51.338' W 094°47.876'

From Current Location 246.7 090°

Delete Show On Map OK

Waypoint Review Page

Creating Waypoints By Text Entry

Waypoints may also be created by manually entering position coordinates through the 'Waypt' tab on the main menu page.

To create a new waypoint by manually entering its coordinates:

1. Press **MENU** twice to display the main menu page.
2. Highlight the 'Waypt' tab and press **MENU**. Then highlight 'New Waypoint' and press **ENTER/MARK**. The New Waypoint page will appear, with the next available waypoint number and the receiver's last known position as the default name and position.
3. Use the **ARROW KEYPAD** to highlight the position coordinates field and press **ENTER/MARK**. Press UP or DOWN on **ARROW KEYPAD** to change the digits, and press RIGHT or LEFT to move to the next number position. Press RIGHT at the end of the top line to move to the bottom line.
4. If you want to change the waypoint name, symbol or enter a depth, highlight the desired field and press **ENTER/MARK**. Use the **ARROW KEYPAD** to enter the new information and press **ENTER/MARK** after the last character in each section.
5. When you have finished, highlight 'OK' and press **ENTER/MARK**.

Reviewing and Editing Waypoints

Once you have created and stored a waypoint, it may be reviewed, modified, moved or deleted at any time through the Waypoint Review and Waypoint Edit pages.

On the Waypoint Review page, you may change the name, symbol, position coordinates, or depth for the selected waypoint, show the waypoint on the map or delete the waypoint. If the selected waypoint is located on a map item or a MapSource item, tabbed information pages for each map feature will be displayed behind the Waypoint Review page. To review the tabbed information pages, use the **ARROW KEYPAD** to highlight the desired tab. The Waypoint Edit page has all the same options as the Waypoint Review page, except it does not include the tabbed information pages for waypoints located on map features.

To access the Waypoint Review page:

1. Use the **ARROW KEYPAD** to highlight the desired waypoint on the map and press **ENTER/MARK**.

Editing Waypoints

To access the Waypoint Edit page:

1. Press **MENU** twice, highlight the 'Waypt' tab, and then highlight a waypoint from the 'By Name', 'Nearest', or 'Proximity' waypoint lists. Press **ENTER/MARK** to display the Waypoint Edit page.

To change the waypoint name:

1. Highlight the waypoint name field and press **ENTER/MARK**.
2. Use the **ARROW KEYPAD** to enter a new name and press **ENTER/MARK** when done.

To change the waypoint symbol:

1. Highlight the waypoint symbol field to the left of the waypoint name and press **ENTER/MARK**.
2. Use the **ARROW KEYPAD** to select the desired symbol and press **ENTER/MARK** when done.

To change the position coordinates:

1. Highlight the position coordinate field and press **ENTER/MARK**.
2. Use the **ARROW KEYPAD** to edit the coordinates. To drop to the next line, press to the right on the **ARROW KEYPAD**. Press **ENTER/MARK** when done.

To enter a depth:

1. Highlight the depth field and press **ENTER/MARK**. If the Sonar was on and active at the time the waypoint was created, a depth will already be shown.
2. Use the **ARROW KEYPAD** to enter a depth. Press UP or DOWN to change the digits and press RIGHT or LEFT to move the cursor. Press **ENTER/MARK** when done.

Waypoint Edit	
▣	005
N 38°51.338'	Depth
W094°47.876'	-----'
From Current Location	
246.7'	090°
S Delete	Show On Map Next

Waypoint Edit Page

Waypoint Options

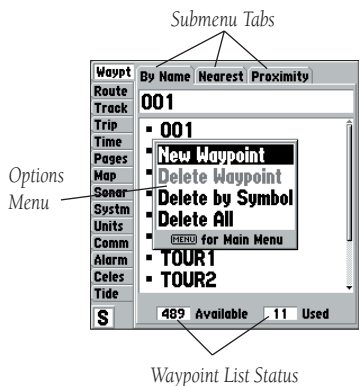

Waypoint Submenus

The GPSMAP 168 Sounder's Main Menu Page features three waypoint submenu tabs, 'By Name', 'Nearest', and 'Proximity', that let you manage a large number of waypoints quickly and efficiently. The submenu tabs also provide a continuously updated nearest waypoints list and a proximity waypoint alarm function that can be used to define an alarm circle around submerged hazards, shallow waters, etc.

To access the Main Menu Page/Waypoint (Waypt) submenus:

1. Press **MENU** twice, then highlight the 'Waypt' tab using the **ARROW KEYPAD**, then highlight the desired submenu tab.

By Name Waypoint List

The first waypoint submenu list available from the 'Waypt' tab is the 'By Name' list, which displays a master list of all waypoints currently stored in memory. From the 'By Name' list, you may review, edit, rename or delete individual waypoints, or delete all user waypoints. The total number of stored and available waypoints is displayed at the bottom of the 'By Name' tab, with the stored waypoints arranged in numerical/alphabetical order.

The following options are available from the 'By Name' submenu of the 'Waypt' tab:

- New Waypoint— creates a new waypoint.
- Delete Waypoint— deletes selected waypoint from list AND any route in which it was used.
- Delete by Symbol— deletes all waypoints that use the same symbol.
- Delete All— deletes all waypoints from the unit.



Once a waypoint is deleted from the list, it cannot be recovered from the unit. It is advisable to backup important waypoints to a computer using GARMIN's MapSource software.

To display the waypoint menu options:

1. Using the **ARROW KEYPAD**, highlight the 'By Name' tab and press the **MENU** key.

To scroll through and review the waypoint list:

1. With the **ARROW KEYPAD**, highlight the 'Waypt' tab from the Main Menu Page and then highlight 'By Name'.
2. Use the **ARROW KEYPAD** to scroll through the list in the desired direction.
3. Press **ENTER/MARK** to review the highlighted waypoint on the Waypoint Edit Page.
4. Press **ENTER/MARK** to return to the list.

(To create a new waypoint using the waypoint menu, see page 50.)

To delete an individual waypoint from the list:

1. Use the **ARROW KEYPAD** to highlight the waypoint to be deleted and press **MENU**.
2. Highlight 'Delete Waypoint' and press **ENTER/MARK**. You may also highlight the waypoint, press **ENTER/MARK**, then highlight 'Delete' and press **ENTER/MARK**.
3. Press the **ENTER/MARK** key to confirm the deletion warning.

To delete waypoints by symbol:

1. From the 'By Name' tab, highlight the waypoint to be deleted and press the **MENU** key, then select 'Delete By Symbol' and press **ENTER/MARK**.
2. Use the **ARROW KEYPAD** to highlight the symbol of the waypoint(s) to be deleted and press **ENTER/MARK**.
3. Press **ENTER/MARK** to confirm. You may also choose 'Cancel' or press **QUIT** to stop the deletion.

To delete all waypoints or the entire waypoint list:

1. Press the **MENU** key to select the options window.
2. Use the **ARROW KEYPAD** to highlight 'Delete All' and then press **ENTER/MARK**.
3. Highlight the 'OK' prompt and press **ENTER/MARK** to confirm.

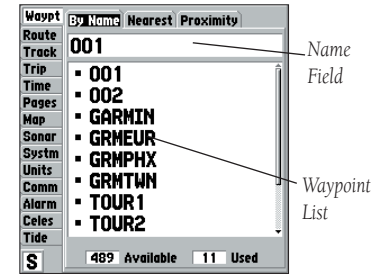
Waypoint Options

You can also search for a waypoint by name:

1. Highlight the name field and press **ENTER/MARK**.
2. Use the **ARROW KEYPAD** to select the first letter of the name.
3. Move to the **RIGHT** and enter the second letter if you do not see it on the list below.
4. Repeat this until the name appears. Press **ENTER/MARK** when you see the name.
5. Highlight the name on the list and press **ENTER/MARK** again to review the waypoint.

Reference

Nearest/Proximity Waypoint Lists

Waypt	By Name	Nearest	Proximity
Route	Waypoint	Brg	Dist
Track	002	298 ^s	25.6 ^s
Trip	GARMIN	249 ^s	68.8 ^s
Time	001	346 ^s	347 ^s
Pages	FISH 2	199 ^s	9.0 ^m
Map	STUMP	200 ^s	10.0 ^m
Sonar	ROCK	201 ^s	10.6 ^m
System	RCKPILE	203 ^s	11.7 ^m
Units	FISH3	219 ^s	12.1 ^m
Alarm	STUMP BED	213 ^s	12.2 ^m
Celes	SAND	209 ^s	12.5 ^m
Tide			

Nearest Waypoint List

Waypt	By Name	Nearest	Proximity
Route	Proximity Alarm		
Track	On		
Trip	Waypoint	Distance	
Time	RCKPILE	0.01 ^m	
Pages	WRECK	0.10 ^m	
Map			
Sonar			
System			
Units			
Comm			
Alarm			
Celes			
Tide			

Proximity Waypoint List

Nearest Waypoint List

The second waypoint submenu list available from the 'Waypt' tab is the 'Nearest' list, which shows the ten nearest waypoints that are within 100 miles of your present position. The nearest waypoints are continuously updated to your present position, and provide quick access to the closest points of safety in emergency situations.

To scroll through and review the nearest waypoint list:

1. Highlight the 'Nearest' tab, then use the **ARROW KEYPAD** to scroll through the list in either direction.
2. Press **ENTER/MARK** to review the highlighted waypoint.
3. To return to the waypoint list, highlight the 'OK' prompt and press **ENTER/MARK**.
4. The field highlight will automatically scroll to the next waypoint. If you want to review each waypoint, you can scroll through any waypoint list by pressing the **ENTER/MARK** key repeatedly.

To select a nearest waypoint as a NAV/MOB destination:

1. Use the **ARROW KEYPAD** key to select the desired waypoint.
2. Press **NAV/MOB**, followed by **ENTER/MARK**.

Proximity Waypoint List

The third waypoint submenu list available from the 'Waypt' tab is the 'Proximity' list, which lets you define an alarm circle around a stored waypoint position, and can be used to help you avoid reefs, rocks or restricted waters. Up to ten waypoints may be listed, with a maximum alarm radius of 99.99 nautical or statute miles or kilometers. If a proximity alarm circle overlaps with an existing alarm circle, a 'Proximity Overlaps Another Proximity Waypoint' message will appear each time the unit is turned on. If you enter an alarm circle overlap, you will only be alerted to the closest proximity waypoint.

The following options are available from the 'Proximity' submenu of the 'Waypt' tab:

- Add Waypoint— adds a waypoint to the proximity list from the waypoint list.
- Clear Alarm— removes selected waypoint from proximity list.
- Clear All— removes all waypoints from proximity list.

To display the proximity waypoint menu options:

1. Using the **ARROW KEYPAD**, highlight the 'Proximity' tab and press the **MENU** key.

To add a proximity waypoint:

1. From the 'Proximity' tab menu options, use the **ARROW KEYPAD** to highlight 'Add Waypoint' and press **ENTER/MARK**. The 'Find' screen appears.
2. Use the **ARROW KEYPAD** to select a category from the 'Find' list. Select a point from the chosen category and press **ENTER**. The 'Waypoint Review' page will be displayed.
3. Press **ENTER/MARK** to confirm. The distance field will now be highlighted.
4. Press **ENTER/MARK** to begin entry of the proximity radius.
5. Use the **ARROW KEYPAD** to enter a distance value (to 99.99 units) and press **ENTER/MARK**.

Proximity Waypoints

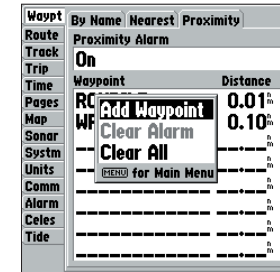

Proximity Tab Options Menu

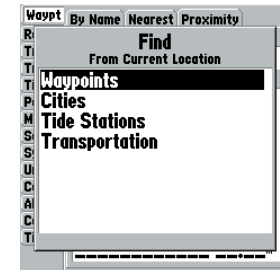

'Find' list.

Reference

Proximity Alarms

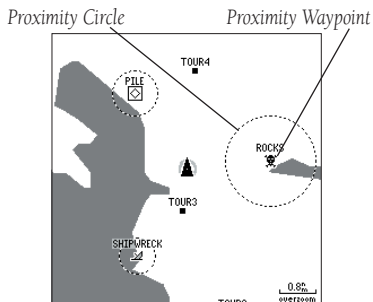

A dashed circle will appear showing the alert boundary for the proximity waypoints.

To turn proximity alarms on or off:

1. Use the **ARROW KEYPAD** to highlight the field below 'Proximity Alarm' and press **ENTER/MARK**.
2. Select the desired 'ON' or 'OFF' setting and press **ENTER/MARK**.

To clear one or all proximity waypoint(s) from the list:

1. Use the **ARROW KEYPAD** to highlight the proximity waypoint to clear and then press the **MENU** key.
2. To clear a single alarm, highlight the 'Clear Alarm' field and press **ENTER/MARK**.
3. To clear all proximity waypoints, select the 'Clear All' option and press **ENTER/MARK**.
4. Use the **ARROW KEYPAD** to highlight the 'OK' prompt and press **ENTER/MARK** to confirm.

Going to a Destination

Using the **NAV/MOB** key, the GPSMAP 168 Sounder provides four ways to navigate to a destination: Go To Waypoint, Follow Track (TracBack), MOB (Man OverBoard), and Follow Route navigation. Once you are actively navigating, you will see a straight line that always runs from the point where navigation originated, to the destination. The easiest method for selecting a destination is the 'Go To' function, which lets you select a destination waypoint and quickly sets a direct course from your present position. If you have a waypoint highlighted on a list or the map, 'Go To <waypoint name>' will appear in addition to 'Go To Waypoint'. The 'Go To' function can be accessed from a list of waypoints or graphically from the map display.

To activate a 'Go To' from the find list:

1. Press the **NAV/MOB** key.
2. Use the **ARROW KEYPAD** to highlight 'Go To Point' and press **ENTER/MARK**. The 'Find' list will be displayed.
3. Select a category (i.e. Waypoint, City, Facilities, Transportation) from the 'Find' list, then using the **ARROW KEYPAD** select a point from that category. Press **ENTER/MARK** to display a review page for the selection, then with the 'GO TO' button highlighted, press **ENTER/MARK** to begin navigation.

Selecting a 'Go To' Graphically

A graphical 'Go To' may be used to select one of three items from the map display: an existing waypoint, an on-screen map item (roads, rivers, cities, nav aids, etc.), or a new map point (non-map item). If you are selecting a map item as the 'Go To' destination, the GPSMAP 168 Sounder will automatically use the name of the map item, but the point will not be stored in the waypoint list. See page 49 for creating waypoints using map items. If you are selecting a new map point (non-map item) as the 'Go To' destination, the GPSMAP 168 Sounder will automatically create or move a waypoint named 'MAP' at the cursor position.

To activate an existing waypoint or map item as a 'Go To' from the map display:

1. Use the **ARROW KEYPAD** to highlight the waypoint or map item on screen and press **NAV/MOB**.
2. You will see 'Go To <waypoint name>', then press **ENTER/MARK**.

To activate a new map point (non-map item) as a 'Go To' from the map display:

1. Use the **ARROW KEYPAD** to move the arrow cursor to the desired position.
2. Press **NAV/MOB**, you will see 'Go To MAP Point' highlighted, then press **ENTER/MARK**.

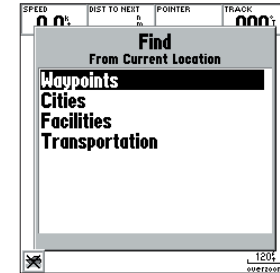
Going to a Destination

Choose a category from 'Find' list then select a point from that category.

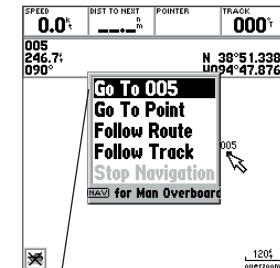

The waypoint or map item name will automatically appear when highlighted and NAV/MOB is pressed.

TracBack Navigation



'Go To MAP Point' allows you to navigate to a spot on the map which is not a waypoint or map item.



Highlight 'Save' and press ENTER/MARK to save an active track log.

TracBack Navigation (Follow Track)

The second method of navigating to a destination is by using the TracBack feature. The TracBack function allows you to retrace your path using the track log automatically stored in the receiver's memory, which will eliminate the need to store waypoints along the way. TracBack routes are created by reducing your track log into a route of up to 30 turns and activating an inverted route along those points. Once activated, a TracBack route will lead you back to the oldest stored track log point, so it's a good idea to clear the existing track log at the start of your current trip before you get started.

To clear the track log and define a starting point for a TracBack route:

1. Press the **MENU** key twice to display the Main Menu Page.
2. Using the **ARROW KEYPAD**, highlight the 'Track' tab, then highlight the 'Active' tab to the right.
3. Use the **ARROW KEYPAD** to select the 'Clear' option and press **ENTER/MARK**.
4. Highlight the 'OK' field and press **ENTER/MARK**.

You must first save the track log before you can use the 'Follow Track' feature. The Save feature allows you to store a track log from certain times and dates.

To save a track log:

1. From the Main Menu, use the **ARROW KEYPAD** to highlight the 'Track' tab, then highlight the 'Active' tab to the right.
2. Use the **ARROW KEYPAD** to select the 'Save' option and press **ENTER/MARK**.
3. From the 'Save Back Through' window, highlight the desired time, date, or 'Entire Log' and press **ENTER/MARK**.
4. Next, the track will begin saving and then display the 'Saved Track' window when done. The default name, distance and number of points will be displayed. Highlight 'OK' and press **ENTER/MARK** to save the track.

To activate a TracBack using the NAV/MOB key:

1. Press the **NAV/MOB** key, then highlight the 'Follow Track' option and press **ENTER/MARK**.
2. Highlight the track you wish to follow and press **ENTER/MARK**.
3. Choose either 'Original', which will navigate you from the end to the start of your trip, or 'Reverse', which will navigate you from the start to the end of your trip and press **ENTER/MARK**.

Once a TracBack has been activated, the GPSMAP 168 Sounder will take the track log currently stored in memory and divide it into segments called 'legs'. Up to 30 temporary 'turns' will be created to mark the most significant features of the track log in order to duplicate your exact path as closely as possible. To get the most out of the TracBack feature, remember the following tips:

- Always clear the track log at the point that you want to go back to (dock, etc.).
- The 'Record Mode' option on the track log setup page must be set to 'Fill' or 'Wrap'.
- There must be at least two track log points stored in memory to create a TracBack route.
- If the track log interval is set to the 'Time' option, the route may not follow your exact path (keep the interval set to 'resolution' for best performance) see page 71.
- If the receiver is turned off or satellite coverage is lost during your trip, the TracBack will draw a straight line between any point where coverage was lost and where it resumed.
- If your track log's changes in distance and direction are too complex, 30 waypoints may not mark your path accurately. The receiver then assigns the 30 waypoints to the most significant points of your track, and simplifies segments with fewer changes in direction.

To stop TracBack navigation:

1. Press the **NAV/MOB** key, highlight 'Stop Navigation' and press **ENTER/MARK**.
2. Choose either 'Yes' or 'No' and press **ENTER/MARK** to confirm.

For more information on setting up the Track options and saved tracks, see pages 70-71.

TracBack Navigation

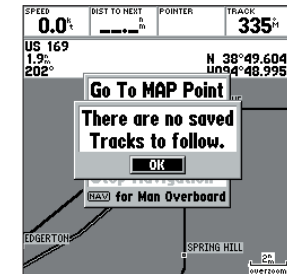
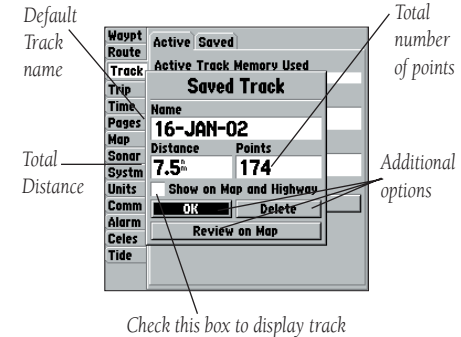

You must first save a track before using the 'Follow Track' option.

Reference

MOB: Man OverBoard

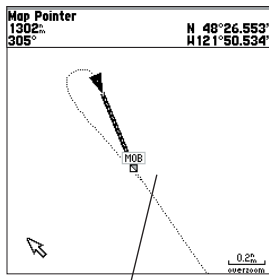

The MOB function allows you to quickly activate a navigation back to a location.

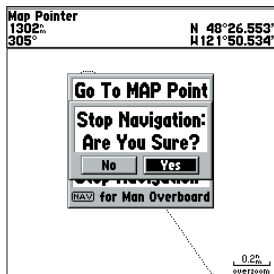

Highlight 'Yes' and press ENTER/MARK to stop navigation.

MOB

The GPSMAP 168 Sounder's Man OverBoard function (MOB) lets you simultaneously mark and set a course to a position for quick response to emergency situations.

To activate the MOB function:

1. Press and hold the **NAV/MOB** key or press the **NAV/MOB** key twice.
2. Press the **ENTER/MARK** key to confirm and begin navigating to the MOB position.

Once a MOB has been activated, a 'MOB' waypoint with a diver down symbol will be created and the unit will be on an active navigation to that point. Use any of the navigation pages to guide you back to the MOB point. The MOB waypoint will be stored in the waypoint list and may be deleted like any other waypoint.

To stop navigation to the MOB position:

1. Press the **NAV/MOB** key, highlight 'Stop Navigation' and press **ENTER/MARK**.
2. Choose either 'Yes' or 'No' and press **ENTER/MARK** to confirm.

Routes

The last way to navigate to a destination is to create a user-defined route. The GARMIN GPSMAP 168 Sounder system lets you create and store up to 20 reversible routes, with up to 30 waypoints each. Routes can be created and modified in two ways. The first way is to 'Edit as Text' from the Route Review Page, allowing you to see a list of the waypoints as you create, review, or modify the route. The second way is from the 'Edit on Map' from the Route Edit Map Page, allowing you to see each route graphically on-screen as you create, review, or modify the route. All of the GPSMAP 168 Sounder's route functions are accessed through the Main Menu Page or the **NAV/MOB** key.

To create a route using text from the Route Review Page:

1. Press the **MENU** key twice to display the Main Menu Page.
2. Use the **ARROW KEYPAD** to highlight the 'Route' tab and press the **MENU** key to display the route options menu.
3. Select the 'New Route' option and press **ENTER/MARK**.
4. Use the **ARROW KEYPAD** to highlight the first empty field under the word 'Waypoint' and press **ENTER/MARK**. This will display the Find menu
5. From the Find menu (see sidebar) , you can select a point from the available options. The options that are available may be different depending on the MapSource data that is loaded in the unit.
6. Keep using the methods on steps 4 and 5 until the desired route points have been entered. Press **QUIT** to return to the Route List Page.

Reference

Creating Routes

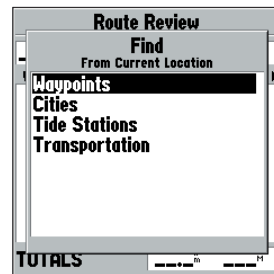

The Find Menu categories can vary depending on the Mapsource data that is currently loaded in the unit. 'Waypoints', 'Cities', 'Tide Stations' and 'Transportation' will always be available. To select a point, highlight a category then press ENTER to display the selections for that category.

Waypoints can be selected 'By Name' or 'Nearest', by selecting the desired tab. If 'Cities' is selected, a list of cities nearest to the current GPS location will be displayed. Pressing the MENU key will display other selection options. For information on selecting Tide Stations, see page 81.

Creating Routes

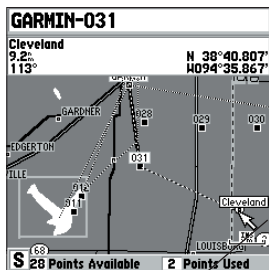

You will see 'ADD' below the cursor as you add points.

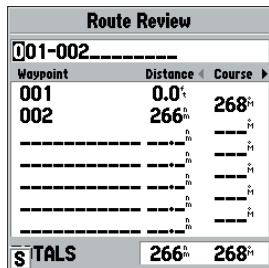

To change the route name, highlight the name field, press ENTER/MARK then use the ARROW KEYPAD to enter a new name.

To create a route graphically from the Route Review page:

1. Press the **MENU** key twice to display the Main Menu page. Use the **ARROW KEYPAD** to highlight the 'Route' tab, then press the **MENU** key to display the route options page.
2. Select the 'New Route' option and press **ENTER/MARK**.
3. Press **MENU**, highlight 'Create on Map' and press **ENTER/MARK**.
4. To add an existing waypoint or map item to the route, use the arrow cursor to highlight the desired waypoint or map item on screen and press **ENTER/MARK**.

To add a map location to the route that is not an existing waypoint or map item, you must mark it as a new waypoint. Use the arrow cursor to select the desired map position and press **ENTER/MARK**. Press **ENTER/MARK** again to confirm the new waypoint. You may also change the name and symbol of the new waypoint (see page 51).

5. As you add each new waypoint to the route, the data window just above the map display will show the waypoint/map item name or 'Map Pointer', bearing and distance from your location, and coordinates of the cursor. The top data window shows the name of the route as it is being created, using the beginning and end points as the default name. The bottom of the display shows the number of available and used points. A route line appears on the map to indicate each completed leg, and a dotted line appears to indicate the distance and bearing to the arrow cursor from the last route waypoint.
6. Repeat steps 4 and 5 until you have finished defining all route waypoints, then press **'QUIT'** or press **'MENU'** and select 'Edit As Text' return to the Review Route Page.
7. To change the route name, highlight the default route name and press **ENTER/MARK**. Use the **ARROW KEYPAD** to change the character and move to the next space. Press **ENTER/MARK** when you have finished changing the route name, press **QUIT** to return to the route list.

Route List Page

The GPSMAP 168 Sounder's Route List page displays all the routes currently stored in memory, along with a descriptive name for each route. Once a route has been created, it can be activated and used for navigation with the **NAV/MOB** key. A route may be followed in the same sequence as it was originally created, or you can invert the route and navigate from the end waypoint back to the beginning waypoint. From the Route list menu, you may choose 'New Route' (pg 61), 'Copy', 'Delete Route', or 'Delete All'.

To activate a route with the NAV/MOB key:

1. From any page, press the **NAV/MOB** key, then using the **ARROW KEYPAD**, highlight 'Follow Route' and press **ENTER/MARK**. (If you highlight a route from the Route List or Route Review page and press **NAV/MOB**, the window will automatically display, 'Follow <the route name>'.)
2. Highlight the route you wish to navigate and press **ENTER/MARK**.
3. Choose 'Activate' or 'Invert and Activate' and press **ENTER/MARK**. ('Activate' will use the route as is, 'Invert and Activate' will reverse the route then activate it.)

To deactivate (stop navigation) of a route:

1. Press the **NAV/MOB** key, highlight 'Stop Navigation' and press **ENTER/MARK**.

To copy or delete a route:

1. From the Route List, using the **ARROW KEYPAD**, highlight the route you want to copy or delete and press **MENU**.
2. Choose either 'Copy' or 'Delete Route' and press **ENTER/MARK** and with "OK" highlighted, press **ENTER/MARK** again to confirm a deletion.

To delete all routes:

1. From the Route List, press **MENU**.
2. Highlight 'Delete All' and press **ENTER/MARK** and with 'OK' highlighted, press **ENTER/MARK** again to confirm the deletion.

Reference

Route List Page

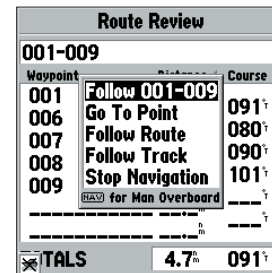

If you highlight a route name from the Route List and press NAV/MOB, the name will automatically appear.



Route List Options Menu

Reference

Route Review Page

The screenshot shows the 'Route Review' page with a table of waypoints. The title is 'Route Review' and the route name is 'TOUR1-TOUR5'. The table has three columns: 'Waypoint', 'Distance', and 'Course'. The waypoints listed are TOUR1, TOUR2, TOUR3, TOUR4, and TOUR5. A 'TOTALS' row is at the bottom. Labels with arrows point to the 'Route Name' (TOUR1-TOUR5), 'Route Points' (TOUR1-TOUR5), and 'Data Fields' (Distance and Course columns).

Waypoint	Distance	Course
TOUR1	0.0 ^h	003 ^h
TOUR2	2.3 ^h	330 ^h
TOUR3	4.8 ^h	001 ^h
TOUR4	7.9 ^h	325 ^h
TOUR5	17.7 ^h	---
TOTALS	17.7 ^h	337 ^h

Data Totals

The screenshot shows the 'Route Review' page with the 'Edit on Map' menu open. The menu options are: 'Edit on Map', 'Insert Waypoint', 'Remove Waypoint', 'Invert', 'Plan Route', and 'Delete Route'. The 'TOTALS' row is visible at the bottom.

Waypoint	Distance	Course
TOUR1	0.0 ^h	003 ^h
TOUR2	2.3 ^h	330 ^h
TOUR3	4.8 ^h	001 ^h
TOUR4	7.9 ^h	325 ^h
TOUR5	17.7 ^h	---
TOTALS	17.7 ^h	337 ^h

Route Review Options Menu

Route Review Page

Once you have created a route, the Route Review Page allows you to review and modify the route displayed.

To get to the Route Review Page:

1. Press **MENU** twice to display the Main Menu, then highlight the 'Route' tab.
2. Highlight the name of the route you wish to review and press **ENTER/MARK**.

The Route Review Page also allows you to enter your own 15-character name for any listed route. By default the name includes the first and last waypoints in the route.

To enter a custom route name:

1. From the Route Review Page, highlight the name field and press **ENTER/MARK** to begin editing.
2. Use the **ARROW KEYPAD** to enter the desired name and press **ENTER/MARK** when finished.

Once you are on the Route Review Page, you may review the route points (waypoints or map items) one at a time from the list:

To review individual route points:

1. Highlight the desired point and press **ENTER/MARK**.
2. On the 'Waypoint Review' window, you may choose 'Next' (highlight the next point on the route list), 'Delete' (permanently delete the waypoint from the unit) or 'Show On Map' and press **ENTER/MARK**.

If the route point is a map item, you may choose 'Create Waypoint' to turn it into a permanent waypoint. Once you are back on the route point list, the next point in the route will automatically be highlighted. This allows you to review each point on the route by pressing only **ENTER/MARK** repeatedly.

Route Review Menu Options

Menu options available from the Route Review Page are Edit on Map, Insert/Add Waypoint, Remove Waypoint, Invert, Plan Route, and Delete Route.

Edit on Map— this option allows you to review and modify the route displayed through a pop-up window menu for each point (waypoint or map item) on a map page. You may also use the cursor to insert a new route point on a route leg, and review the waypoint or map item.

To edit the route on the map:

1. From the Route Review page options menu, select 'Edit on Map' and press **ENTER/MARK**.

To review or modify a route point:

1. Place the cursor on a route point and press **ENTER/MARK**, or press **MENU** and select 'Edit as Text'. On the Waypoint Review page, you may review and modify the waypoint name, symbol, coordinates, and depth, just like on the Waypoint Edit page (see page 51). Make any desired changes and press **ENTER/MARK** again when done.

To remove a route point:

1. Place the cursor on the desired point and press **MENU**. Select 'Remove' and press **ENTER/MARK**.

To move a route point:

1. Place the cursor on the desired point and press **MENU**. Select 'Move' and press **ENTER/MARK**. The cursor will now have 'Move' displayed below it.
2. Move the cursor to the new map position and press **ENTER/MARK** to relocate the point.

To add turns at the beginning or end of the route:

1. Select the first or last route waypoint with the map cursor, and press **MENU**.
2. Highlight the 'Add' option and press **ENTER/MARK**.
3. Move the cursor to the new point or position and press **ENTER/MARK**.
4. If you are not inserting an existing waypoint, press **ENTER/MARK** to confirm the new waypoint.
5. Repeat steps 3 and 4 to insert additional waypoints, or press **QUIT** to finish.

Editing Routes

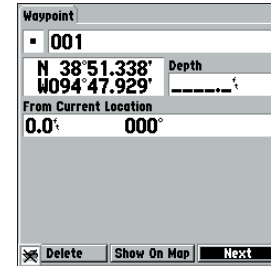

Select a route waypoint on the map, then press **ENTER/MARK** to review the waypoint.

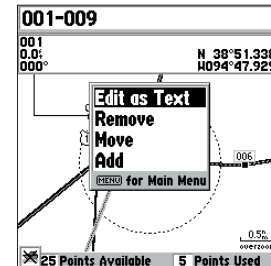

Choose 'Edit as Text' to return to the Route Page

Reference

Editing Routes

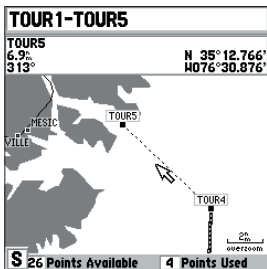

Highlight the route leg on which you wish to insert a waypoint and press **ENTER/MARK**.

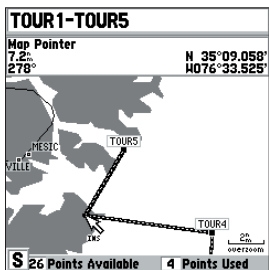

Drag the route leg to an existing waypoint (shown), map item, or a blank spot on the map to create a new route point.

The GPSMAP 168 Sounder's 'Edit on Map' mode also allows you to insert a new route waypoint in any route leg using the map cursor.

To insert a new point between two existing route waypoints:

1. Use the **ARROW KEYPAD** to select the leg you want to insert the new waypoint in (the route line will highlight and change to a dotted line when the leg is selected) and press **ENTER/MARK**.
2. Move the cursor to the new map position, existing waypoint, or map item (You will see 'ADD' below the arrow and the route lines will move with the arrow), and press **ENTER/MARK**.
3. If you are not inserting an existing point, press **ENTER/MARK** to confirm the new waypoint.

Insert/Add Waypoint— Allow you to insert a waypoint into the list of route points or add a point(s) onto the end of the route.

To insert a point into the route or add a point to the end:

1. From either the Route Review or Active Route pages, use the **ARROW KEYPAD** to highlight the point you wish to insert the new point before (to add a point to the end, highlight the blank field at the bottom of the list).
2. Press **MENU**, highlight 'Add Waypoint' or 'Insert Waypoint' and press **ENTER/MARK**.
3. From the 'Find' list, select a point to be inserted/added and press **ENTER/MARK**.

Remove Waypoint— Allows you to remove a point (waypoint or map item) from a route. This option is available from both the Route Review and Active Route Pages.

To remove a point from a route:

1. From either the Route Review or Active Route pages, use the **ARROW KEYPAD** to highlight the point to remove and press **MENU**.
2. Highlight 'Remove Waypoint' and press **ENTER/MARK**.

Invert— The Invert function will reverse the route you choose. This option is available from both the Route Review and Active Route Pages.

To invert a route:

1. From the Route Review or Active Route page, press **MENU**.
2. Using the **ARROW KEYPAD**, highlight 'Invert' and press **ENTER/MARK**.

Plan Route— The Route Review and Active Route pages also display trip-planning information for each leg or the entire route. Available information includes Course, ETA, Fuel (to point), Leg Distance, Leg Fuel, Leg Time, Sunrise and Sunset (at point location) and Time To (point).

To use the Plan Route feature:

1. To select the desired planning figure, highlight the desired route from the Route List and press **ENTER/MARK** to display the Route Review page. If you have an active route, you may also do the following from the Active Route page:
2. One of nine available planning figures appears to the right of each route waypoint and its distance. Use the LEFT/RIGHT keys on the **ARROW KEYPAD** to select the desired item.
3. To enter planning information, Press **MENU**, select 'Plan Route' from the options list, and press **ENTER/MARK**. Enter the figures for Speed, Fuel Flow, Depart(ure) Time, and Depart(ure) Date. Press **QUIT** to return to the Route Plan Page.



Fuel flow rates on your unit are measured in "units per hour." System setting changes for units of measure (statute, nautical or metric) do not affect the fuel flow measure. You should enter fuel flow rates based upon available information for your vehicle (operator's manual, performance specifications, etc.) and make note of the desired units of measure (gallons, liters, etc.).

Delete Route— deletes route and any map item points within route.

To delete a route:

1. From the Route Review page press **MENU**.
2. Highlight 'Delete Route' and press **ENTER/MARK** and **ENTER/MARK** again to confirm the deletion.

Reference

Editing Routes

Route Review		
TOUR5-TOUR1		
Waypoint	Distance	Course
TOUR5	0.0 ^m	145 [°]
TOUR4	9.8 ^m	181 [°]
TOUR3	12.9 ^m	150 [°]
TOUR2	15.4 ^m	183 [°]
TOUR1	17.7 ^m	

TOTALS	17.7^m	157[°]

Press **LEFT** or **RIGHT** on the **ARROW KEYPAD** to change the data field.

Route Review		
TOUR1-TOURS		
Waypoint	Distance	Course
T		
Plan Route		
T	Speed	Depart Time
T	0.0 [°]	06:00 [°]
T	Fuel Flow	Depart Date
T	0.0 ^{°/hr}	01-JAN-06

TOTALS	17.7^m	337[°]

Plan Route Data Fields

Active Route Page

Active Route		
TOUR1-TOURS		
Waypoint	Distance	Course
TOUR1	---	017 ^h
▶ TOUR2	2.3 ^h	344 ^h
TOUR3	4.8 ^h	015 ^h
TOUR4	7.9 ^h	339 ^h
TOUR5	17.7 ^h	---
-----	---	---
-----	---	---
TOTALS	17.7^h	351^h

Active Route Page

Active Route		
TOUR1-TOURS		
Waypoint		Course
TOUR	Edit on Map	017 ^h
▶ TOUR	Insert Waypoint	344 ^h
TOUR	Remove Waypoint	015 ^h
TOUR	Invert	339 ^h
TOUR	Plan Route	---
TOUR	Re-evaluate	---
-----	MENU for Main Menu	---
-----	---	---
TOTALS	17.7^h	351^h

Active Route Page Menu Options

Active Route Page

Whenever you have activated a route in the GPSMAP 168 Sounder system, the Active Route Page shows each point (waypoint or map item) of the active route, with the point name, distance and choice of Course, ETA, Fuel to point, Leg Distance, Leg Fuel, Leg Time, Sunrise and Sunset at point location, or Time To point for each point from your present position. The current destination point, the 'active' point, is marked with an arrow icon. As you navigate a route, the waypoint list will automatically update to indicate the next 'active' point first. The Active Route and Route Review Pages share many of the same features and options.

The following route options are available from the Active Route Page:

- Edit on Map— see page 65 for instructions.
- Insert Waypoint— see page 66 for instructions.
- Remove Waypoint— see pages 66 for instructions.
- Invert— see page 67 for instructions.
- Plan Route— see page 67 for instructions.
- Re-evaluate— recalculates and reactivates the current route data.

Re-evaluate— reactivates the current route and selects the route leg closest to your current position as the active leg. The active leg defines the current 'from' and 'to' waypoints.

To Re-evaluate an active route:

- 1 From the Active Route Page, press **MENU**.
2. Using the **ARROW KEYPAD**, highlight 'Re-evaluate' and press **ENTER/MARK** to recalculate.

Main Menu Page

The GPSMAP 168 Sounder's Main Menu Page provides access to various waypoint, system, navigation and interface management, and setup menus in an easy to use "tab" format. The Main Menu Page is available from any page in the GPSMAP 168 Sounder's system, and is accessed through the **MENU** key.

See pages 2-3 for additional instructions on changing settings and entering data.

To access the Main Menu Page:

1. Press **MENU** twice.

The 14 Menu tabs are divided into categories by function.

To select a Menu tab from the Main Menu Page:

1. Move the **ARROW KEYPAD** UP or DOWN to highlight the tab you want to view. The information for the highlighted tab will automatically appear to the right.
2. If you want to highlight any of the tab items, press to the RIGHT on the **ARROW KEYPAD**, then move UP or DOWN to select individual items.
3. You may then press either **MENU** for additional submenu options or press **ENTER/MARK** to make changes to the highlighted item.
4. Press LEFT on the **ARROW KEYPAD** to get back to the Menu tab list. Pressing **QUIT** will take you out of the Main Menu Page.

The Main Menu tabs are:

- Waypt— allows you to create, edit or delete waypoints. See pages 48-56.
- Route— allows you to create, edit, activate or delete routes. See pages 61-67.
- Track— lets you record a track, define how it is recorded and displayed.
- Trip— provides trip speeds, odometers, averages, and trip timers.
- Time— sets up time format, time zones, and daylight savings.
- Pages— enables main pages to be shut off, turned on, or 'jumped to'.
- Map— sets up Map Page features, zooms, and text size. See pages 32-34.

Main Menu Tabs

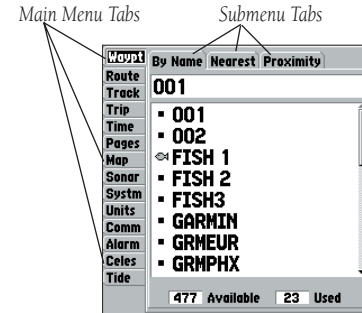

Main Menu Page

Reference

Main Menu: Track Tab



Active Track Tab

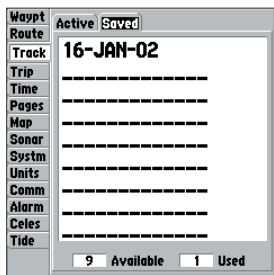

Saved Track Tab

- Sonar— sets up Sonar Page features, speeds and calibrations See pages 42-44.
- Systm— defines beeper and simulator, restores setup, and displays software version.
- Units— defines position format, datum, heading, and distance and speed units.
- Comm— interface settings for use with a PC or second device.
- Alarm— sets up alarms for anchor drag, arrival, off course, and clock.
- Celes— Celestial page shows sun/moon time cycles and positions.
- Tide— Tide page show 12 hour tide chart with levels and times.

Track Tab— lets you specify whether or not to record a track log (an electronic ‘breadcrumb trail’ recording of your path), define how it is recorded, or save track log data for future use. The Track Tab also provides an indicator of the memory used for the active track log and options to clear the track memory or start a TracBack route. See pages 58-59 for TracBack information. The Track submenu is divided in two tabs: the ‘Active’ tab and the ‘Saved’ tab.

The ‘Active’ tab is for the active log (the log currently being recorded). It displays track memory used and current settings.

The ‘Saved’ tab displays and manages a list of any saved track logs, allows TracBack activation and map display of saved logs. The active log stores up to approximately 2000 track log points, based upon the criteria specified in the Track settings. Up to 10 track logs may be saved in memory, with up to 250 track log points in each saved log.

For the ‘Active’ tab, the following settings are available:

- Record Mode— lets you select one of three track recording options:
 - Off— No track log will be recorded. Note that selecting the ‘Off’ setting will prevent you from using the TracBack feature.
 - Fill— a track log will be recorded until the track memory is full.
 - Wrap— A track log will be continuously recorded, wrapping through the available memory (replacing the oldest track data with new data).

- Interval— defines the frequency at which the track plot is recorded. Three interval settings are available:

Time— records track plot based on a user-defined time interval.

Resolution— records track plot based upon a user-defined variance from your course over ground. The resolution option is the default setting and is recommended for the most efficient use of memory and TracBack performance. The distance value (entered in the value field) is the maximum error allowed from the true course before recording a track point.

Distance— records track based on a user-defined distance between points.

- Value— defines the distance or time used to record the track log.
- Save— allows you to save the current active track log.
- Clear— allows you to clear the active track log currently stored in memory.

For the 'Saved' tab, the following options are available by pressing **MENU**:

- Show Map— displays the saved track log on a Track Map page.
- Delete Track— deletes highlighted saved track log from memory.
- Delete All— deletes all saved track logs from memory.

You may also activate a TracBack from any track on the 'Saved' tab.

To activate a TracBack from the 'Saved' tab list:

- Using the **ARROW KEYPAD**, highlight the track you wish to use for a TracBack and press **NAV/MOB**.
- The 'Follow <track name>' will automatically appear highlighted. Press **ENTER/MARK**.
- Choose either 'Original', which will navigate you from the end to the start of your trip, or 'Reverse', which will navigate you from the start to the end of your trip and press **ENTER/MARK**.

Main Menu: Track Tab

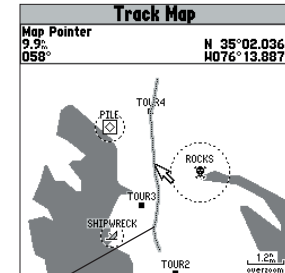

You can use the 'Show Map' option to display a saved track.



The track name will automatically appear when highlighted on the 'Saved' list and NAV/MOB is pressed.

Reference

Main Menu: Trip, Time and Pages Tabs

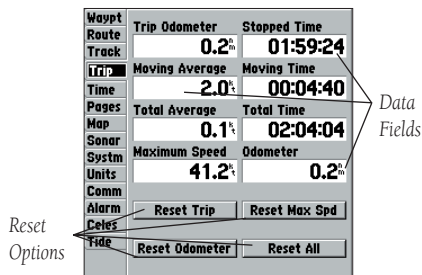

Trip Tab

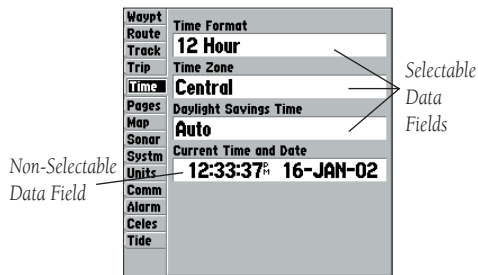

Time Tab

Trip Tab— displays Trip Odometer, Moving Average speed, Total Average speed, Maximum Speed, Stopped Time, Moving Time, Total Time, and Odometer. You may reset the data by choosing from 'Reset Trip', 'Reset Odometer', 'Reset Max Spd (speed)', or 'Reset All' and pressing **ENTER/MARK**.

Time Tab— displays the current time and date, allows you to adjust the 12 or 24 hour time format, enter a time zone and adjust for daylight savings to show correct local time.

The following options are available:

- Time Format— choose from 12 or 24 hour (military) time format.
- Time Zone— choose your correct time zone to show correct local time or enter a UTC Offset. The UTC (also called Greenwich Time) offset is how many hours you are ahead or behind the time line. See the table on page 85 for time offsets.
- Daylight Savings— choose from 'Auto', 'On', or 'Off' to adjust for daylight savings.

Pages Tab— allows you to turn on/off any of the main pages or 'Jump To' a particular page.

To select/deselect a main page:

1. Use the **ARROW KEYPAD** to highlight the box to the left of the page name. Pressing **ENTER/MARK** will select/deselect that page. When a page is selected, a '✓' will appear in the box. You must leave at least one page checked.

You may also press **MENU** and choose from one of the following and press **ENTER/MARK**:

- Enable All Pages— selects all pages.
- Basic Chartplotter— selects Map Page only.
- Nav Tools Only— selects Compass, Highway, and Active Route Pages only.
- Basic Fishfinder— selects Sonar Page only.

To 'Jump To' a specific page:

1. Use the **ARROW KEYPAD** to highlight the 'Jump To' option to the right of the desired page and press **ENTER/MARK**.

System (System) Tab— controls system setting for beeper, speed filter, languages, system mode, simulator controls, restores factory settings, and displays software version.

The following settings are available:

- **Beeper**— controls audible beep. Select from 'Off', 'Alarms Only' (sounds for alarms/messages), 'Key and Alarm' (sounds for key presses and alarms/messages).
- **Speed Filter**— averages speed-readings. Choose from 'Off', 'Auto' (automatically controls filtering), or 'On' (allows you to enter a value from 1 to 255 seconds).
- **Language**— select from 11 languages for the unit's on-screen display.
- **System Mode**— select from 'Normal' (normal navigation), 'Simulator' (for practice ONLY), 'Sounder Only' or 'GPS Only'.
- **Track Control***— 'Auto Track' will steer to the current navigation point. 'User Track' allows you to enter a heading in the 'Track' field.
- **Speed***— lets you enter a speed.
- **Track***— lets you enter a heading.
- **Set Position***— allows to set your location while in simulator mode. See page 11, starting with step 2, for additional instructions.
- **Transducer*** — lets you select a transducer type, 'Depth Only', 'Temp' or 'Temp/Speed'.

* These fields will only appear when the unit is in Simulator Mode.

The following options are available by pressing **MENU** from the 'System' tab:

- **Restore GARMIN Setup**— restores all settings to GARMIN's original setup values for the entire unit.
- **Software Version**— displays the unit's software, basemap version and serial number.

Reference

Main Menu: System (System) Tab

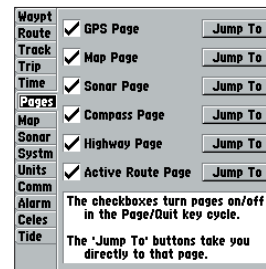

Pages Tab

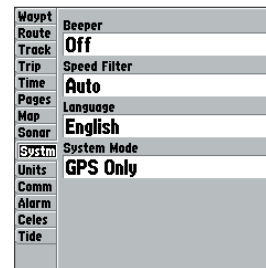

System (System) Tab

Reference

Main Menu: Units Tab



The Units tab settings will affect how navigation information is displayed on the GPSMAP 168 Sounder. When in doubt, seek assistance.

If you are using a map or chart in conjunction with your GPS, make sure the settings under the 'Units' tab of the GPSMAP 168 Sounder match that of the map or chart. This information should be displayed somewhere on the map or chart. If the information is not present, contact the map or chart maker to determine what position format, datum, heading and units of measure are being used for the map or chart.

Waypt	Position Format
Route	hddd°mm.mmm'
Track	hddd°mm.mmm'
Trip	Map Datum
Time	WGS 84
Pages	Headings
Man	Auto Mag Var 003°E
Sonar	Distance, Speed and Elevation
System	Distance, Speed and Elevation
UNITS	Nautical (nm, kt, ft)
Comm	Depth
Alarm	Feet (ft)
Celes	Temperature
Tide	Fahrenheit (°F)

Units Tab

Units Tab— defines the settings for Position Format, Map Datum, Heading, and the units of measure for Distance, Speed, Elevation, Depth and Temperature.

The following settings are available:

- Position Format— is used to change the coordinate system in which a given position reading is displayed. You should only change the position format if you are using a map or chart that specifies a different position format or wish to use a format you are familiar with. The default format is latitude and longitude in degrees, minutes, and thousandths of a minute (hddd°mm.mmm'). The following additional formats are available:
 - hddd.dddd°— latitude/longitude in decimal degrees only
 - hddd°mm'ss.s"— latitude/longitude in degrees, minutes, seconds
 - UTM/UPS— Universal Transverse Mercator / Universal Polar Stereographic grids
 - British Grid
 - Dutch Grid
 - Finnish KKKJ27
 - German Grid
 - Irish Grid
 - Maidenhead
 - MGRS
 - New Zealand
 - Qatar Grid
 - RT 90
 - Swedish Grid
 - Swiss Grid
 - Taiwan Grid
 - Loran TD
 - User Grid
 - W Malayan RSO

For additional information on Loran TD setup, see pages 83-84.

- Map Datum— allows you to select the datum reference used to determine a given position. The default setting is 'WGS 84'. Datums are used to describe geographic positions for surveying, mapping, and navigation and are not actual maps built in the unit. Although over 100 datums are available (as listed on pages 88-89), you should only change the datum if you are using a map or chart that specifies a different datum.



WARNING: Selecting the wrong map datum can result in substantial position errors. When in doubt, use the default WGS 84 datum for best overall performance.

Reference

Main Menu: Units Tab

- **Heading**— lets you select the reference used in calculating heading information. You can select from 'Auto Mag Var', 'True', 'Grid' and 'User Mag Var'. 'Auto Mag Var' provides magnetic north heading references which are automatically determined from your current position. 'True' provides headings based upon a true north reference. 'Grid' provides headings based on a grid north reference (and is used in conjunction with the grid position formats described on page 74). 'User Mag Var' allows you to specify the magnetic variation at your current position and provides magnetic north heading references based upon the variation you enter.

To enter a user defined magnetic variation:

1. With the "Heading" field set to 'User Mag Var', highlight the heading reference field (immediately to the right) and press **ENTER/MARK**.
2. Use the **ARROW KEYPAD** to enter the magnetic variation at your current position and press **ENTER/MARK**.



WARNING: If 'User Mag Var' is selected, you must periodically update the magnetic variation as your position changes. Using this setting, the unit will not automatically calculate and update the magnetic variation at your present position. Failure to update this setting may result in substantial differences between the information displayed on your unit and external references, such as a magnetic compass.

- **Distance, Speed and Elevation**— lets you select the desired units of measure for distance, speed and elevation readouts in 'Nautical' (nm, kt, ft), 'Statute' (mi, mh, ft) or 'Metric' (km, kh, mt) terms.
- **Depth**— lets you select the desired units of measure for depth in Feet (ft), Fathoms (fa) or Meters (mt).
- **Temperature**— lets you select the desired units of measure for temperature in Fahrenheit (°F) or Celsius (°C).

Waypt	Position Format
Route	hddd°mm.mmm'
Track	Map Datum
Trip	WGS 84
Time	Heading
Pages	User Mag Var 000°E
Map	Distance, Speed and Elevation
Sonar	Units (nm, kt, ft)
Systm	Depth
Units	Feet (ft)
Comm	Temperature
Alarm	Fahrenheit (°F)
Celes	
Tide	

You may manually enter a magnetic variation.

Reference

Main Menu: Comm Tab

Data
Transfer
Progress

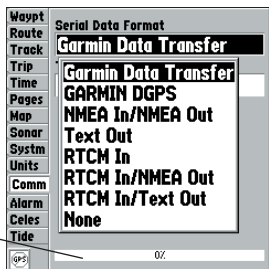

Comm Tab Serial Data Formats

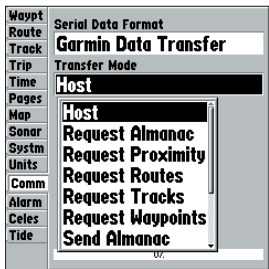

Comm Tab Transfer Modes

Comm (Communications) tab— lets you control the input/output format used when connecting your GPSMAP 168 to external NMEA devices, a DGPS beacon receiver, a personal computer, another GARMIN GPSMAP 168/168, etc. Eight format settings are available:

- GARMIN Data Transfer—the proprietary format used to upload/download MapSource data, exchange waypoint, route, track, almanac, and proximity data with a PC or another GARMIN GPSMAP 168/168. When you select 'GARMIN Data Transfer', there are 11 Transfer Modes to choose from: Host, Request Almanac, Request Proximity, Request Routes, Request Tracks, Request Waypoints, Send Almanac, Send Proximity, Send Routes, Send Tracks and Send Waypoints.
- GARMIN DGPS— used to connect the GPSMAP 168 with a GARMIN DGPS beacon receiver.
- NMEA In/NMEA Out— supports the input/output of standard NMEA 0183 version 2.3 data, and sonar NMEA input support for the DPT, MTW and VHW sentences. See Appendix I on page 108 for the Advanced NMEA Setup feature.
- Text Out— outputs simple text (ASCII) output which contains time, position, and velocity data.
- RTCM In— allows DGPS input using a standard RTCM format, without any output capabilities.
- RTCM In/NMEA Out— allows Differential GPS (DGPS) input using a standard RTCM format and also provides NMEA 0183 version 2.3 output.
- RTCM In/Text Out— allows Differential GPS (DGPS) input using a standard RTCM format and also provides simple text (ASCII) output which contains time, position, and velocity data.
- None— provides no interfacing capabilities.

To select an input/output format:

1. Highlight the 'Serial Data Format' field and press **ENTER/MARK**.
2. Use the **ARROW KEYPAD** to select the desired setting and press **ENTER/MARK**.

To select a transfer mode:

1. Use the **ARROW KEYPAD** to select 'GARMIN Data Transfer' in the 'Serial Data Format' field.
2. Highlight the 'Transfer Mode' field and press **ENTER/MARK**.
3. Use the **ARROW KEYPAD** to select the desired setting and press **ENTER/MARK**.

To restore the Serial Data Format settings to the default 'GARMIN Data Transfer':

1. From the Comm tab, press **MENU**, highlight 'Restore Defaults' and press **ENTER/MARK**.

If 'GARMIN DGPS' or 'RTCM In/NMEA Out' format is selected, additional fields are provided to control a GARMIN differential beacon receiver directly from your GPSMAP 168. You may have the unit automatically scan for the DGPS beacon signal or you can enter the beacon frequency and bit rate on the unit and the information will be used to tune the beacon receiver.

To have the unit automatically scan for a frequency:

1. With the unit set to 'GARMIN DGPS' or 'RTCM In/NMEA Out', use the **ARROW KEYPAD** to highlight the "Beacon" field and press **ENTER/MARK**.
2. Highlight 'Scan' and press **ENTER/MARK**. The numbers in the "Frequency" field will change as the unit scans from 284 kHz to 325 kHz, 200 bit rate, then 100, at 6-second intervals.

To restart the scan:

1. Press **MENU**, highlight 'Restart Scan' and press **ENTER/MARK**.

To manually enter a frequency and bit rate:

1. With the unit set to 'GARMIN DGPS' or 'RTCM In/NMEA Out', use the **ARROW KEYPAD** to highlight the "Beacon" field and press **ENTER/MARK**.
2. Highlight 'User' and press **ENTER/MARK**.
3. Highlight the "Frequency" or "Bit Rate" field, press **ENTER/MARK**, then enter a frequency or bit rate and press **ENTER/MARK** when done.

The "Status" field will show one of the following:

- Tuning— unit is attempting to tune to the specified frequency and bit rate.
- Scanning— unit is automatically scanning through the frequencies and bit rates.
- Receiving— unit is receiving DGPS signal and ready for operation.
- Check Wiring— unit is not making connection with DGPS receiver.

When the unit is receiving a DGPS signal, the "SNR" (Signal to Noise Ratio) and "Distance" fields will show data. The SNR range is 0dB to 30dB, with 30 being the best. The Distance may or may not show data, depending upon the signal being broadcast from the DGPS site.

Reference

Main Menu: Comm Tab

Waypt	Serial Data Format			
Route	GARMIN DGPS			
Track	Baud	Status		
Trip	4800	Tuning		
Time	Pages	Beacon	Bit Rate	Frequency
Map	User	200	293.0 ^{kHz}	
Sonar	SNR	Distance		
Systm	---	dB	---	n
Units				
Comm				
Alarm				
Celes				
Tide				

You may also manually enter a bit rate and frequency.

Waypt	Serial Data Format			
Route	GARMIN DGPS			
Track	Baud	Status		
Trip	4800	Tuning		
Time	Pages	Beacon	Bit Rate	Frequency
Map	User	200	312.0 ^{kHz}	
Sonar	SNR	Distance		
Systm	---	dB	---	n
Units				
Comm				
Alarm				
Celes				
Tide				

Status Field

SNR and Distance will show data when signal is received.

Reference

Main Menu: Alarm Tab

Waypt	Anchor Drag	Off	0.00 ^m
Route			
Track	Arrival	Time	00:00:15
Trip			
Time	Off Course	Off	0.00 ^m
Pages			
Map	Clock	Off	12:00 ^h
Sonar			
System	Shallow Water	Off	20.0 ^f
Units			
Comm	Deep Water	Off	100.0 ^f
Alarm			
Ceiles	Fish	Off	
Tide	Battery	Off	11.2 ^v

Alarm Tab

The DGPS beacon transmitters are operated by the U.S. Coast Guard (or similar government agency in other countries), which is responsible for their accuracy and maintenance. For DGPS transmitter problems or to find the most updated list of frequencies and coverage areas, contact your local USCG, or see their web site at <http://www.navcen.uscg.mil/>.

Alarm Tab— allows you to turn an alarm On or Off and define the alarm setting for Anchor Drag, Arrival, Off Course, Clock, Shallow Water, Deep Water, Fish and Battery.

- Anchor Drag— sets an alarm to sound when you've exceeded a specified drift distance. Enter a distance up to 9.99 miles or kilometers in the distance field and use the control field to turn the alarm on and off.
- Arrival— sets an alarm to sound when you're a specified distance or time away from a destination waypoint. Enter a distance radius or time for sounding the alarm and use the control field to set the alarm to 'Off', 'Dist' (Distance), or 'Time'.
- Off Course— sets an alarm to sound when you're off a desired course by a specified distance. Enter a distance from 0 to 99.99 units in the distance field and use the control field to turn the alarm on and off.
- Clock— provides an alarm for the system clock. Enter a time in the time field and turn the alarm on and off from the control field menu. Remember to enter alarm times in the same time format (UTC or local) you're using for your system. The unit must be on for the clock alarm to work.
- Shallow Water— sets an alarm to sound when you enter an area of specified depth that is too shallow. Enter a depth range from 0 to 999.99 in the distance field and use the control field to turn the alarm on and off.
- Deep Water— sets an alarm to sound when you enter an area of specified depth that is too deep. Enter a depth range from 0 to 999.99 in the distance field and use the control field to turn the alarm on and off.
- Fish— sets an alarm to sound when the unit detects a fish. Choose from 3 symbol settings: Large, Medium and Small Fish; Large and Medium Fish Only; Large Fish Only. Use the control field to turn the alarm on and off.
- Battery— sets an alarm to sound when the unit reads a specific input voltage. Enter a voltage range from 10.0 vDC to 16.0 vDC and use the control field to turn the alarm and and off.

To set an alarm:

1. Use the **ARROW KEYPAD** to highlight the field to the right of the alarm name you wish activate and press **ENTER/MARK**.
2. Change the mode to 'On' (Distance or Time for the 'Arrival' alarm) and press **ENTER/MARK**.
3. Highlight the next field to the right and press **ENTER/MARK**, then enter the desired settings and press **ENTER/MARK** to finish.



In order to hear an audible alarm, you must have the beeper turned on (page 73).

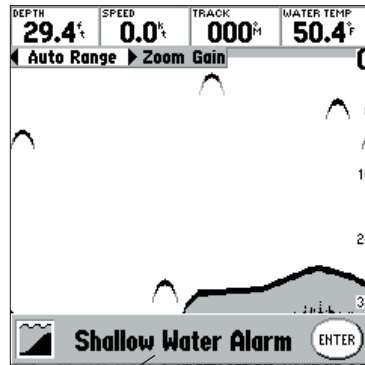

When an alarm is activated, a message will appear at the bottom of the display screen.

Reference

Main Menu: Alarm Tab

Waypt	Anchor Drag	Off	0.00 ^m
Route	Track	Arrival	Time 00:00:15
Trip	Off Course	Off	0.00 ^m
Time	Clock	On	10:30 ^m
Pages	Shallow Water	Off	0.0 ^m
Map	Deep Water	Off	0.0 ^m
Sonar	Fish	Off	
Systm	Battery	Off	11.2 ^v
Units			
Comm			
Alarm			
Celes			
Tide			
S			

Setting the Clock Alarm

Waypt	Anchor Drag	Off	0.00 ^m
Route	Track	Arrival	Time 00:00:15
Trip	Off Course	Off	0.00 ^m
Time	Clock	On	09:05 ^m
Pages	Shallow Water	Off	0.0 ^m
Map	Deep Water	Off	0.0 ^m
Sonar	Fish	Off	
Systm			
Units			
Comm			
Alarm			
Celes			
	Alarm Clock		ENTER

Press **ENTER/MARK** to acknowledge an alarm and clear the message.

Reference

Main Menu: Celes (Celestial) Tab

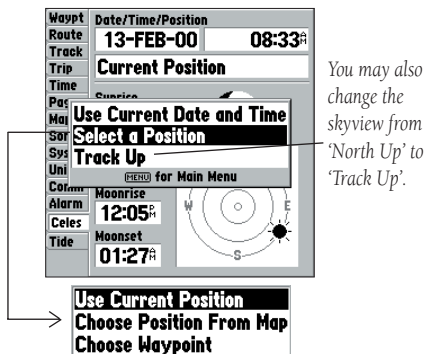
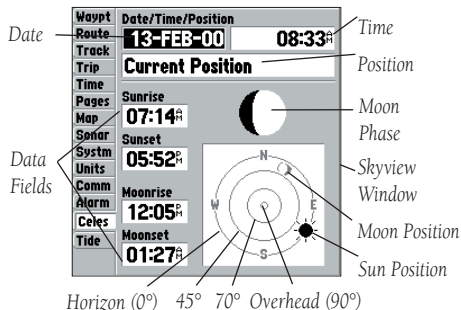

'Select a Position' Sub-Menu Options

Celes (Celestial) Tab— displays celestial data for sun and moon rise/set, moon phase, and approximate skyview location of the sun and moon. The moon phase will display the current visible portion of the moon as a light color. You may display this data for your current position, a position from the map, or a waypoint location. Also, you may select a different date and time, or use the current data.

To choose a position:

1. Highlight the 'Position' field and press ENTER. This will display the Find Menu.
2. Select from 'Current Location', 'Other Location', or one of the available categories. The categories available will vary depending on the MapSource data that is currently loaded in the unit.

If 'Current Location' is selected the unit will search for the Tide Station nearest to the current GPS location. If 'Other Location' is selected, a map will be displayed allowing a location to be selected using the cursor. The location the unit is using will appear in the Date/Time/Position field. The timetables displayed will be based upon your current time zone. When using a position from another location outside of your time zone, you will need to set the Time Zone for that location under the 'Time' tab on the Main Menu (see page 72).

To change the time or date:

1. use the **ARROW KEYPAD** to highlight the date or time and press **ENTER/MARK**.
2. Enter a new date or time and press **ENTER/MARK**.

To use the current date and time:

1. From the 'Celes' tab, press **MENU**, then use the **ARROW KEYPAD** to highlight 'Use Current Date and Time' and press **ENTER/MARK**.

Tide Tab— shows a graphical chart which displays tide station information in a 24 hour span starting at midnight station time. You can choose from different dates and over 3000 tide stations around the USA coastline, Alaska, Hawaii, western Canada and several of the Caribbean islands.

The top of the page displays the tide station being referenced, below that the date. The top of the chart shows a 24-hour block of local time (LCL) for your position, with the reported station time (STA) appearing at the bottom. Daylight (light bar) and nighttime (dark bar) show across the time scale, with the time progressing from left to right. (Local time scales and sunrise/sunset info may not be available for a few stations). The solid, light vertical lines are in 4-hour increments, and the light, dotted vertical lines are in 1-hour increments. A dark, vertical line (with arrows at the ends of the line) will indicate the time of day when using current date and will intersect the tide graph to show their relation.

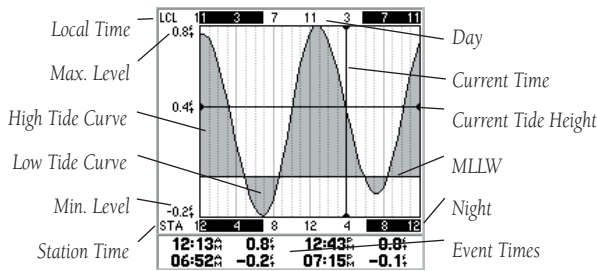

The tide curve shows as a shaded area, with higher tides being taller and lower tides shorter. The dark, horizontal line (with arrows at the ends of the line) indicates the current tide height. The figure to the left of the line will show the current tide level in feet. The Mean Lower Low Water (MLLW) appears as a solid, vertical line near the bottom of the chart (This line will only appear if the tide ranges to the zero value or below). The numbers directly below/above 'LCL' and 'STA' indicate the maximum/minimum levels, respectively. The four data fields below the chart, indicate event times and levels at which the tide changes starting in the upper left field, going downward, then to the upper right and down again.

Reference

Main Menu: Tide Tab

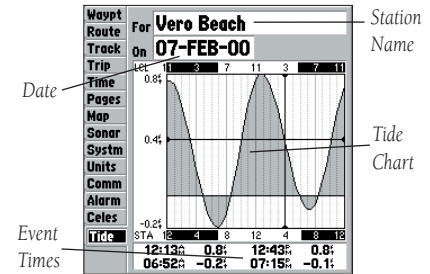

Tide Tab

Reference

Main Menu: Tide Tab

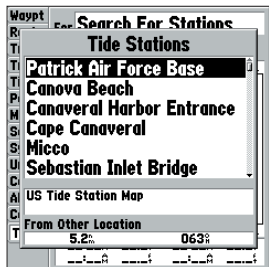

The Tide Station page will show a list of available Tide Stations, beginning with the station that is nearest to the current GPS location.

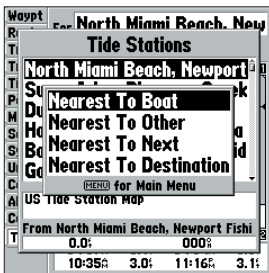

You may automatically search for the nearest station and also view past and future information.

The name of the Tide Station nearest to your current location will appear in the 'For' field. You must be within 100 miles of a tide station for a station name to be displayed. If you are not within this range, a message "Search For Stations." will be displayed in the 'For' field. To search for a Tide Station, highlight the 'For' field and press **ENTER**. If no Tide Stations are found, pressing the **MENU** key will display the search options, 'Nearest To Boat', 'Nearest To Other'. If the unit is actively navigating, the options 'Nearest To Next', 'Nearest To Destination' will also be available. 'Nearest to Next' will display Tide Stations nearest to the next active waypoint in a route, 'Nearest To Destination' will display Tide Stations nearest to the destination waypoint in a route or an active Goto waypoint.

Search for Tide Stations 'Nearest To Boat':

1. From the 'Tide' tab, highlight the 'For' field and press **ENTER/MARK**.
2. With the Tide Stations list displayed, press **MENU**.
3. Using the **ARROW KEYPAD**, highlight 'Nearest To Boat' and press **ENTER/MARK**.
4. A list will appear showing up to nine of the nearest tide stations. Highlight the desired station and press **ENTER/MARK**.

Search for Tide Stations 'Nearest To Other':

1. From the 'Tide' tab, highlight the 'For' field and press **ENTER/MARK**.
2. With the Tide Stations list displayed, press **MENU**.
3. Using the **ARROW KEYPAD**, highlight 'Nearest To Other' and press **ENTER/MARK**.
4. A map will be displayed, using the **ARROW KEYPAD**, place the cursor over the desired area and press **ENTER/MARK**. The unit will search for Tide Stations in the selected area and display them in the Tide Stations list.

To change the date for the tide chart:

1. Using the **ARROW KEYPAD**, highlight the 'On' field and press **ENTER/MARK**.
2. Enter the desired date and press **ENTER/MARK**.

To use the current date:

1. Press **MENU**, then highlight 'Use Today's Date' and press **ENTER/MARK**.

Loran TD System

Loran C is a radio navigation aid operated and maintained in the United States by the United States Coast Guard. The name LORAN is an acronym for “LOng RANge Navigation.” The Loran system covers the entire United States and the U.S. Coastal Confluence Zone. From the perspective of a mariner, the system is used for ocean and coastal navigation. It can be used as a supplemental system for harbor and harbor approach navigation, and it is used for inland navigation by recreational vehicles.

Loran TD Feature

The Loran TD (Time Delay) feature eases the transition from using Loran to using GPS. The GPSMAP unit automatically converts GPS coordinates to Loran TDs for those who have a collection of Loran fixes for favorite fishing spots and other waypoints recorded as TDs. You can display your position as a TD or enter waypoints as TDs. The accuracy to be expected from this conversion is approximately 30 meters. When the unit is placed in the Loran TD format mode, it simulates the operation of a Loran receiver. Position coordinates may be displayed as TDs, and all navigation functions may be used as if the unit was actually receiving Loran signals.

Using the Loran TD Format

When creating new waypoints using Loran TD coordinates, you must set the correct Loran chain number and secondary stations in the Setup TD field before storing the waypoint. After the waypoint is stored in unit memory, it will always reference the Loran chain number and secondary stations currently selected in the Setup TD field. If you enter a different Loran chain number, change the secondary stations or offsets in the Setup TD field, the active waypoint information will reflect those changes. Since the GPSMAP unit does not rely on the Loran signal for navigation, it can reference a different GRI chain and/or secondary stations and still navigate to the location stored in memory.

The Loran Position Format field is located under the ‘Units’ tab in the Main Menu. The ‘Loran TD Setup’ window contains the fields to select the Loran GRI-Chain Number, Primary and Secondary Stations, and TD Offsets.

Appendix A

Loran TD

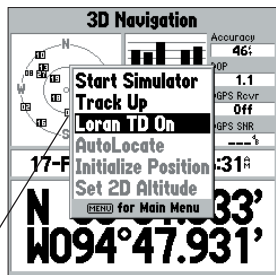

You may change to Loran TD from either the Status Page or Units Tab on the Main Menu.

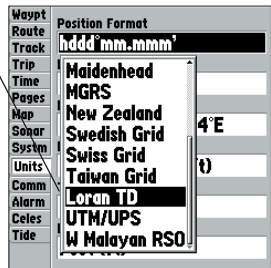

Appendix A

Loran TD

Waypt	Position Format
Route	Loran TD
Track	Setup
Trip	Loran TD Setup
Time	Loran Chain Number
Page	GRI_8970
Map	TD Station 1 TD Offset 1
Sond	W 0.0
Syst	TD Station 2 TD Offset 2
Unit	Y 0.0
Com	
Alarm	
Celex	
Tide	Depth
	Feet (ft)

Loran TD Setup Page

3D Navigation	
Accuracy	56'
Loran TD Setup	
Loran Chain Number	
GRI_8970	
GRI_8970	Offset 1
GRI_9007	0.0
GRI_9610	Offset 2
GRI_9930	0.0
GRI_9940	
GRI_9960	9238.6

Selecting the Loran Chain Number.



When inputting Loran coordinates, you must have the correct chain number, secondary station identifiers (first and second), and proper map datum available for the TD coordinates you input into the GPS unit. For better position accuracy, navigate to the Loran point, then re-mark the point with a GPS unit in LAT/LON format.

To setup Loran TD from the Main Menu:

1. Using the **ARROW KEYPAD**, highlight the 'Units' tab and then the 'Position Format' field and press **ENTER/MARK**.
2. Highlight 'Loran TD', press **ENTER/MARK**, then highlight 'Setup' and press **ENTER/MARK**.
3. To change the settings of any of the five fields, highlight the field, press **ENTER/MARK**, select/enter the desired setting and press **ENTER/MARK**.
4. When done, press the **QUIT** key to return to the Main Menu.

To setup Loran TD from the Status Page:

1. Press **MENU**, then use the **ARROW KEYPAD**, highlight the 'Loran TD On' and press **ENTER/MARK**.
2. To change the settings of any of the five fields, highlight the field, press **ENTER/MARK**, select/enter the desired setting and press **ENTER/MARK**.
3. When done, press the **QUIT** key to return to the Status Page.

If the active GRI Chain, secondary stations or offsets have been changed since the waypoint was created, the waypoint will now reference the active GRI-chain and secondary stations and adjust the TD coordinates accordingly. Remember that the GPS is not relying on the Loran signal for navigation and actually converts the TD coordinate to a useful LAT/LON coordinate (in the background) before storing the waypoint to memory or using it for navigation. Because of this, the unit can navigate to a TD coordinate anywhere in the world.

The chart below gives an approximate UTC (Universal Time Coordinate) time offset for the various longitudinal zones. Check with local charts for more detailed information. If you are in daylight savings time, add one hour to the offset.

Longitudinal Zone	Offset	Longitudinal Zone	Offset
W180.0° to W172.5°	-12	E007.5° to E022.5°	+1
W172.5° to W157.5°	-11	E022.5° to E037.5°	+2
W157.5° to W142.5°	-10	E037.5° to E052.5°	+3
W142.5° to W127.5°	-9	E052.5° to E067.5°	+4
W127.5° to W112.5°	-8	E067.5° to E082.5°	+5
W112.5° to W097.5°	-7	E082.5° to E097.5°	+6
W097.5° to W082.5°	-6	E097.5° to E112.5°	+7
W082.5° to W067.5°	-5	E112.5° to E127.5°	+8
W067.5° to W052.5°	-4	E127.5° to E142.5°	+9
W052.5° to W037.5°	-3	E142.5° to E157.5°	+10
W037.5° to W022.5°	-2	E157.5° to E172.5°	+11
W022.5° to W007.5°	-1	E172.5° to E180.0°	+12
W007.5° to E007.5°	0		

Appendix B

Time Offsets



A simple way to determine your local time offset is how many hours you are behind or ahead of UTC (also called 'Greenwich' or 'zulu' time).

Example: EST (Eastern Standard Time) is 5 hours behind UTC, so your offset would be -5. Adding one hour for daylight savings would make EDT (Eastern Daylight Time) -4. Subtract an hour for each time zone as you travel west.

Offsets for Continental U.S. would be:

EST	-5	EDT	-4
CST	-6	CDT	-5
MST	-7	MDT	-6
PST	-8	PDT	-7

Appendix C

Messages

The GPSMAP 168 Sounder uses an on-screen pop-up message system to alert you to unit operating characteristics. Press the **ENTER** key to acknowledge and return to the page you were viewing.

Alarm Clock— The alarm clock has sounded.

Alarm Voltage Set Too High Set to 16.0V— Voltage range must be between 10.0 and 16.0 volts. Adjust setting.

Alarm Voltage Set Too Low Set to 10.0V— Voltage range must be between 10.0 and 16.0 volts. Adjust setting.

Anchor Drag Alarm— You have drifted out of the specified distance range.

Antenna Input Shorted To Ground— Check antenna wiring/connections or antenna replacement.

Approaching Waypoint— You are a specified alarm distance from a destination waypoint.

Arrival At Waypoint— You have arrived at the destination waypoint.

Basemap Failed Unit Needs Repair— Internal problem with the unit. Contact your dealer or GARMIN Customer Service (pg. iv) to have the unit serviced.

Battery Alarm— Specified amount of input voltage has been detected.

Battery Voltage High Please Check Connection— Input DC voltage is too high for unit.

Battery Voltage Low Please Check Connection— Input DC voltage is too low for unit.

Boat is Not Moving Fast Enough to Calibrate— Speed wheel is not turning. Check for debris or boat speed is too slow.

Database Error— Internal problem with the unit. Contact your dealer or GARMIN Customer Service (pg. iv) to have the unit serviced.

Deep Water Alarm— Specified deep water alarm depth has been detected below transducer.

Lost Satellite Reception— The unit has lost satellite signals. Check antenna connections or try moving to a location with a clear view of the sky.

Memory (RAM) Failed Unit Needs Repair— Internal problem with the unit. Contact your dealer or GARMIN Customer Service (pg. iv) to have the unit serviced.

Memory (ROM) Failed Unit Needs Repair— Internal problem with the unit. Contact your dealer or GARMIN Customer Service (pg. iv) to have the unit serviced.

No DGPS Position— No differential correction data is available or not enough data is available to compute a DGPS position.

No Tide Stations For That Area— There are no tide stations within 100 miles of the specified point. Try another area.

Off Course Alarm— You have exceeded the specified off-course distance.

Processor Failed Unit Needs Repair— Internal problem with the unit. Contact your dealer or GARMIN Customer Service (pg. iv) to have the unit serviced.

Messages

Proximity Alarm List is Full— You have used all ten proximity waypoints.

Proximity Alarm Waypoint— You have entered the alarm radius for the proximity waypoint indicated.

Proximity Overlaps Another Proximity Waypoint—The alarm radius specified overlaps the area specified for another proximity waypoint. Adjust the distance.

Route Already Exists: <route name>— You have entered a route name that already exists in memory. Modify the route name or delete the previous route name.

Route Does Not Exist: <route name>— Route has been renamed or removed from memory and cannot be used.

Route Is Full— You have attempted to add more than 30 points to a route. Reduce the number of points or create a second route.

Route Memory Is Full Can't Create Route— Maximum amount of 20 routes is already in the unit's memory and no additional routes can be added until existing ones are removed.

Route Truncated— An uploaded route from another device has more than 30 points. Reduce the number of points.

Running Simulator— The unit is in simulator (practice) mode.

Shallow Water Alarm— Specified shallow water alarm depth has been detected below transducer.

Sonar Failed Unit Needs Repair— Internal problem with the unit. Contact your dealer or GARMIN Customer Service (page. iv) to have the unit serviced.

Track Already Exists: <track name>— You have entered a saved track name that already exists in memory. Modify the track name or delete the previous track name.

Track Memory Is Full Can't Create Track— Track log memory is full. No additional track log data can be stored without deleting old data to create memory space.

Track Truncated— A complete uploaded track will not fit into memory. The oldest track log points were deleted to make space for the most recent data.

Transducer Disconnected Sonar Turned Off— No transducer attached or bad cable/transducer.

Transfer Complete— The unit has finished uploading/downloading information to the connected device.

Water Speed Sensor is Not Working— Speed sensor is not detected. Check connections.

Waypoint Already Exists: <waypoint name>— You have entered a waypoint name that already exists in memory. Modify the waypoint name or delete the previous waypoint name.

Waypoint Memory Is Full Can't Create Waypoint— You have used all 500 waypoints available. Delete unwanted waypoints to make space for new entries.

Appendix D

Map Datums



The GPSMAP's built-in world-wide database includes coverage down to 20 n.m. (30 km). Note that the GPSMAP 168 Sounder basemap is valid to 75° north and 60° south of latitude.



The 'User' datum is based on a WGS-84-Local datum and is an advanced feature for unlisted or custom datums. Check your local library or on the world wide web for educational materials on datums and coordinate systems.

Adindan	Adindan- Ethiopia, Mali, Senegal, Sudan	Djakarta	Djakarta (Batavia)- Sumatra Island (Indonesia)
Afgooye	Afgooye- Somalia	Dos 1968	Dos 1968- Gizo Island (New Georgia Islands)
AIN EL ABD '70	AIN EL ANBD 1970- Bahrain Island, Saudi Arabia	Dutch	Dutch
Anna 1 Ast '65	Anna 1 Astro '65- Cocos I.	Easter Isld 67	Easter Island 1967
ARC 1950	ARC 1950- Botswana, Lesotho, Malawi, Swaziland, Zaire, Zambia, Zimbabwe	European 1950	European 1950- Austria, Belgium, Denmark, Finland, France, Germany, Gibraltar, Greece, Italy, Luxembourg, Netherlands, Norway, Portugal, Spain, Sweden, Switzerland
ARC 1960	Kenya, Tanzania	European 1979	European 1979- Austria, Finland, Netherlands, Norway, Spain, Sweden, Switzerland
Ascnsn Isld '58	Ascension Island '58- Ascension Island	Finland Hayfrd	Finland Hayford- Finland
Astro B4 Sorol	Sorol Atoll- Tern Island	Gandajika Base	Gandajika Base- Republic of Maldives
Astro Bcn "E"	Astro Beacon "E"- Iwo Jima	GDA	Geocentric Datum of Australia
Astro Dos 71/4	Astro Dos 71/4- St. Helena	Geod Datm '49	Geodetic Datum '49-New Zealand
Astr Stn '52	Astronomic Stn '52- Marcus Island	Guam 1963	Guam 1963- Guam Island
Aus Geod '66	Australian Geod '66- Australia, Tasmania Island	Gux 1 Astro	Guadalcanal Island
Aus Geod '84	Australian Geod '84- Australia, Tasmania Island	Hjorsey 1955	Hjorsey 1955- Iceland
Austria	Austria	Hong Kong '63	Hong Kong
Bellevue (IGN)	Efate and Erromango Islands	Hu-Tzu-Shan	Taiwan
Bermuda 1957	Bermuda 1957- Bermuda Islands	Indian Bngldsh	Indian- Bangladesh, India, Nepal
Bogata Observ	Bogata Observatry- Colombia	Indian Thailand	Indian- Thailand, Vietnam
Campo Inchspe	Campo Inchauspe- Argentina	Indonesia 74	Indonesia 1974-Indonesia
Canton Ast '66	Canton Astro 1966- Phoenix Islands	Ireland 1965	Ireland 1965- Ireland
Cape	Cape- South Africa	ISTS 073 Astro	ISTS 073 ASTRO '69- Diego Garcia
Cape Canavrl	Cape Canaveral- Florida, Bahama Islands	Johnston Island	Johnston Island Kandawala Kandawala- Sri Lanka
Carthage	Carthage- Tunisia	Kerguelen Islnd	Kerguelen Island
CH-1903	CH 1903- Switzerland	Kertau 1948	West Malaysia, Singapore
Chatham 1971	Chatham 1971- Chatham Island (New Zealand) Chua Astro Chua Astro- Paraguay	L.C. 5 Astro	Cayman Brac Island
Corrego Alegre	Corrego Alegre- Brazil		

Liberia 1964	Liberia 1964- Liberia
Luzon Mindanao	Luzon- Mindanao Island
Luzon Philippine	Luzon- Philippines (excluding Mindanao Isl.)
Mahe 1971	Mahe 1971- Mahe Island
Marco Astro	Marco Astro- Salvage Isl.
Massawa	Massawa- Eritrea (Ethiopia)
Merchich	Merchich- Morocco
Midway Ast '61	Midway Astro '61- Midway
Minna	Minna- Nigeria
NAD27 Alaska	North American 1927- Alaska
NAD27 Bahamas	North American 1927- Bahamas (excluding San Salvador Island)
NAD27 Canada	North American 1927- Canada and Newfoundland
NAD27 Canal Zn	North Am. 1927- Canal Zone
NAD27 Caribbn	North American 1927- Caribbean (Barbados, Caicos Islands, Cuba, Dom. Rep., Grd. Cayman, Jamaica, Leeward and Turks Islands)NAD27 Central North American 1927-Central America (Belize, Costa Rica, El Salvador, Gua- temala, Honduras, Nicaragua)
NAD27 CONUS	North Am. 1927- Mean Value (CONUS)
NAD27 Cuba	North American 1927- Cuba
NAD27 Grnland	North American 1927- Greenland (Hayes Peninsula)
NAD27 Mexico	N. American 1927- Mexico
NAD27 San Sal	North American 1927- San Salvador Island
NAD83	North American 1983- Alaska, Canada, Central America, CONUS, Mexico
Naparima BWI	Naparima BWI- Trinidad and Tobago

Nhrwn Masirah	Nahrwn- Masirah Island (Oman)
Nhrwn Saudi A	Nahrwn- Saudi Arabia
Nhrwn United A	Nahrwn- United Arab Emirates
Obsrvtorio '66	Observatorio 1966- Corvo and Flores Islands (Azores)
Old Egyptian	Old Egyptian- Egypt
Old Hawaiian	Old Hawaiian- Mean Value
Oman	Oman- Oman
Ord Srvy GB	Old Survey Grt Britn- England, Isle of Man, Scotland, Shetland Isl., Wales
Pico De Las Nv	Canary Islands
Potsdam	Potsdam-Germany
Prov S Am '56	Prov So Amrcn '56- Bolivia, Chile, Colombia, Ecuador, Guyana, Peru, Venezuela
Prov S Chln '63	So Chilean '63- S. Chile
Ptcairn Ast '67	Pitcairn Astro '67- Pitcairn
Puerto Rico	Puerto Rico & Virgin Isl.
Qatar National	Qatar National- QatarQornoq Qornoq- South Greenland
Reunion	Reunion- Mascarene Island
Rome 1940	Rome 1940- Sardinia Isl.
RT 90	Sweden
Santo (Dos)	Santo (Dos)- Espirito Santo
Sao Braz	Sao Braz- Sao Miguel, Santa Maria Islands
Sapper Hill '43	Sapper Hill 1943- East Falkland Island
Schwarzeck	Schwarzeck- Namibia
SE Base	Southeast Base- Porto Santo and Madiera Islands
South Asia	South Asia- Singapore
Sth Amrcn '69	S. American '69- Argentina, Bolivia, Brazil, Chile, Colombia, Ecuador, Guyana, Paraguay, Peru, Venezuela, Trin/Tobago

Appendix D

Map Datums

SW Base	Southwest Base- Faial, Graciosa, Pico, Sao Jorge and Terceira Islands
Timbalai 1948	Timbalai 1948- Brunei and E. Malaysia (Sarawak and Sabah)
Tokyo	Tokyo- Japan, Korea, Okinawa
User	User-defined custom datum
Tristan Ast '68	Tristan Astro 1968- Tristan da Cunha
Viti Levu 1916	Viti Levu 1916- Viti Levu/Fiji Islands
Wake-Eniwetok	Wake-Eniwetok- Marshall
WGS 72	World Geodetic System 72
WGS 84	World Geodetic System 84
Zanderij	Zanderij- Surinam

Appendix E

Navigation Terms

Altitude— Height above mean sea level (MSL).

Avg Speed— The average of all second-by-second speed readings since last reset.

Bearing (BRG)— The compass direction from your present position to a destination waypoint.

Course— The desired course between the active 'from' and 'to' waypoints.

Distance (Dist)— The 'great circle' distance from present position to a destination waypoint.

Dist to Dest— The 'great circle' distance from present position to a GOTO destination or to the final waypoint in a route.

Dist to Next— The 'great circle' distance from present position to a GOTO destination or to the next waypoint in a route.

ETA— Estimate Time of Arrival. The estimated time you will reach your destination waypoint, based on current speed and track.

ETA at Dest— The estimated time you will reach a GOTO destination or the final waypoint in a route.

ETA at Next— The estimated time you will reach a GOTO destination or the next waypoint in a route.

Fuel— The fuel required to travel from present position to the indicated route waypoint.

Leg Dist— The distance between two route waypoints.

Leg Fuel— The fuel required to travel from a route waypoint to the next waypoint (in sequence) in the route.

Leg Time— The time required to travel from a route waypoint to the next waypoint (in sequence) in the route.

Max Speed— The maximum second-by-second speed recorded since last reset.

Moving Average Speed— Average speed while the unit is moving.

Moving Trip Timer— Total time the unit has been moving.

Odometer— A running tally of distance travelled, based upon the distance between second-by-second position readings.

Off Course— The distance you are off a desired course in either direction, left or right. Also referred to as ‘cross-track error’ or ‘course error’.

Speed— The current velocity at which you are travelling, relative to a ground position. Also referred to as ‘ground speed’.

Time To— The estimated time required to reach a GOTO destination or the next waypoint in a route. Also referred to as ‘estimated time en route’.

Time to Dest— The estimated time required to reach a GOTO destination or the final waypoint in a route.

Time to Next— The estimated time required to reach a GOTO destination or the next waypoint in a route.

To Course— The recommended direction to steer in order to reduce course error or stay on course. Provides the most efficient heading to get back to the desired course and proceed along your route.

Track— The direction of movement relative to a ground position. Also referred to as ‘ground track’.

Trip Odometer— A running tally of distance travelled since last reset. Also see ‘Odometer’.

Total Average Speed— Average speed of unit for both moving and stopped speeds since last timer reset.

Total Trip Timer— Total time the unit has been in operation since last reset of the trip timers.

Turn— The angle difference between the bearing to your destination and your current track. ‘L’ indicates you should turn left, ‘R’ indicates you should turn right. The degrees indicate the angle you are off course.

VMG— Velocity Made Good. The speed you are closing in on a destination along a desired course. Also referred to as the ‘vector velocity’ to your destination.

Appendix E

Navigation Terms

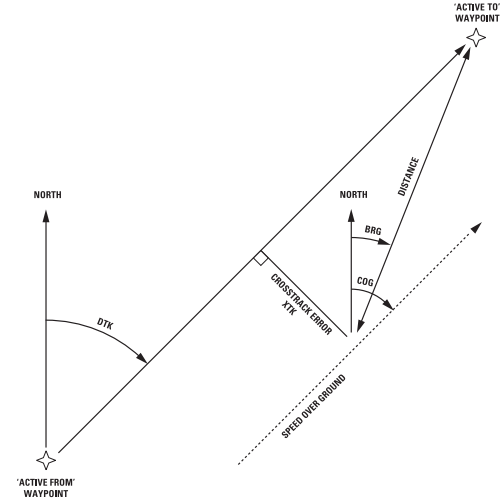

Appendix F

Specifications

Physical Specifications

Size:	4.63" H x 6.0" W x 2.75" D (11.7cm x 15.2cm x 7cm)
Weight:	1 lb. 6 oz. (.763 kg)
Display:	4.2" diagonal (10.7cm) high-contrast, 4-level gray LCD with backlighting (240 x 240 pixels)
Case:	Fully gasketed, high-impact plastic alloy, waterproof to IEC 529-IPX-7
Temperature Range:	5°F to 158°F (-15°C to 70°C)

Performance

Receiver:	Differential-ready 12 parallel channel receiver tracks all satellites in view
Acquisition Times:	
Warm:	Approx. 15 seconds
Cold:	Approx. 45 seconds
AutoLocate:	Approx. 5 minutes
Update Rate:	1/second, continuous
Position Accuracy:	15 meters (49 feet) RMS; 1-5 meters (3-15 feet) RMS with optional GARMIN DGPS receiver
Velocity:	0.1 knot RMS steady state
Dynamics:	6g's
Sounder Power:	150 watts (RMS), 1200 watts (peak to peak)
Frequency:	200 kHz

Power

Source:	10-18v DC
Usage:	10 watts max.
Fuse:	AGC/3AG - 2 Amp

Installing the GPSMAP 168 Sounder

The GPSMAP 168 Sounder must be properly installed according to the following instructions to get the best possible performance. If you have the 168 Sounder with the built-in internal bail mount antenna (010-00202-00), you may skip this section and proceed to the next page. For unit's purchased with the external GA 29 antenna (010-00199-00), follow the instructions below. To complete the installation, you'll need the appropriate fasteners and a 1" x 14-thread marine antenna mount available at most marine dealers.

Mounting the GPS Antenna

The antenna should be mounted in a location that has a clear, unobstructed view of the sky in all directions to ensure the best reception. Avoid mounting the antenna where it will be shaded by the boat's superstructure, a radome antenna, or mast. The GPS antenna should be mounted about 2.5-3 feet away from the radar dome. Sailboat users should avoid mounting the antenna high on the mast to prevent inaccurate speed readings caused by excessive heeling. Most marine VHF and LORAN antennas should not seriously degrade the GPS antenna's reception. Never paint the antenna or clean it with harsh solvents.

The GARMIN antenna screws directly onto any standard 1" x 14-thread antenna mount. If you need to raise the antenna to avoid shading, try using a 1" x 14-thread extension mast available at most marine dealers.

To install the GPS antenna:

1. Screw the antenna directly onto the 1" x 14-thread mount.
2. Route the cable to the mounting location of the display unit. Use the appropriate tie-wraps, fasteners and sealant to secure the cable along the route and through any bulkhead or deck.
3. Once the GPSMAP 168 Sounder unit has been installed, connect the cable to the antenna connector on the back of the display unit. Make sure that you turn the antenna cable connector 1/4 turn clockwise to lock the cable into place.

Antenna Installation

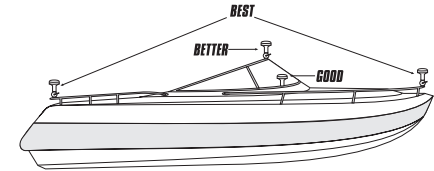

Suggested locations for mounting the GA 29 antenna.



It is possible to route the coaxial cable either through or outside the antenna mount. The BNC connector on the coaxial cable can be removed, and the coaxial cable shortened to ease installation. If the BNC connector is removed it must be replaced with a new crimp, compression or solder-on BNC connector. If you need assistance, please contact GARMIN Technical Support at 913-397-8200.

Appendix G

Unit Installation

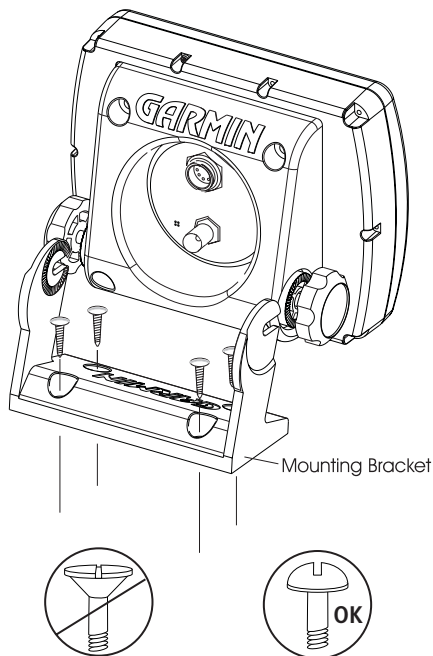

The Mounting Bracket is designed to be secured using a flat head screw. If you use a screw with a countersunk head, you risk damaging the Mounting Bracket.

Mounting the GPSMAP 168 Sounder Unit

The GPSMAP 168 Sounder's compact, waterproof case is suitable for mounting in exposed locations or at the nav station. The unit comes with a gimbal bracket for surface or overhead mounting. When choosing a location for the display unit, make sure you consider the following conditions:

- There should be at least a 3" (5 cm) clearance behind the case to allow connection of the antenna (external antenna only) and power/data cables.
- The mounting surface should be heavy enough to support the unit and protect it from excessive vibration and shock.
- For units with the built-in internal bail mount antenna, it should be mounted in a location that has the clearest, most unobstructed view of the sky in all directions to ensure the best reception. Avoid mounting the unit where it will be blocked by the boat's superstructure, a radar arch or mast.



The temperature range for the GPSMAP 168 Sounder is 5°F to 158°F (-15°C to 70°C). Extended exposure to temperatures exceeding this range (in storage or operating conditions) may cause failure of the LCD screen. This type of failure and related consequences are NOT covered by the manufacturer's limited warranty.

To install the GPSMAP 168 Sounder unit:

1. Place the mounting bracket in the desired location.
2. Mark and drill the four mounting holes for the fastener you are using.
3. Fasten the bracket to the surface using the appropriate fastener.
4. Insert the GPSMAP 168 Sounder into the mounting bracket. The bracket is designed for a tight fit to provide additional support when swiveling the unit.
5. Screw the two mounting knobs through the bracket and into the display case.
6. Connect the power/data and antenna cables (external antenna only) to the back of the unit, making sure the locking rings are fully tightened on both connectors.

Connecting the Power/Data

The power/data cable connects the GPSMAP 168 Sounder to a 10-18 volt DC system and provides interface capabilities for connecting external devices. The color code in the diagram below indicates the appropriate harness connections. Replacement fuse is a AGC/BAG - 2 Amp fuse.

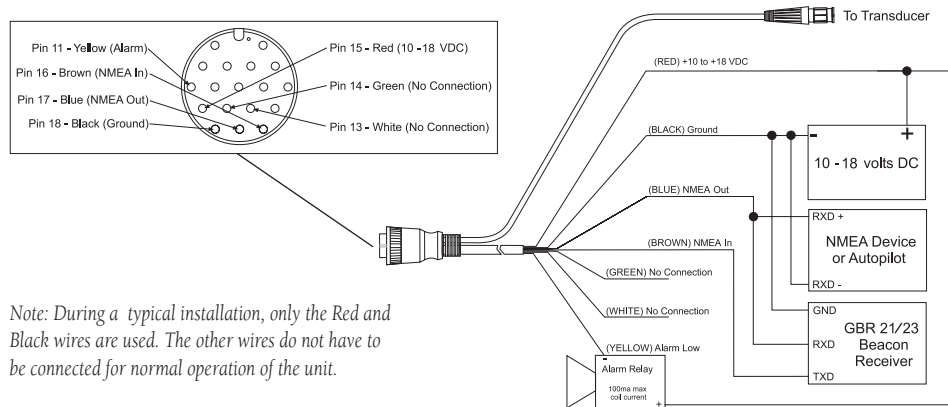

Note: During a typical installation, only the Red and Black wires are used. The other wires do not have to be connected for normal operation of the unit.

Interfacing

The following formats are supported for connection of external devices: GARMIN proprietary Differential GPS (DGPS), NMEA 0183 (version 2.3), ASCII Text Output, RTCM SC-104 input (version 2.0).

The following are the sentences for NMEA 0183, version 2.3 output: Approved sentences—GPRMC, GPGGA, GPGSA, GPGSV, GPGLL, GPBOD, GPRTE, GPWPL, SDBBT, SDDPT, SDMTW and SDVHW; Proprietary sentences—PGRME, PGRMZ, and PSLIB. The GPSMAP 168 Sounder also includes NMEA input with support for the WPL sentence.

You can download a copy of GARMIN's proprietary communication protocol from the Help and Support section of our website at www.GARMIN.com.

Appendix G

Wiring and Interfacing

If your boat has an electrical system, it may be possible to wire the unit directly to an unused holder on your current fuse block. If you are using the boat's fuse block, remove the in-line fuse holder supplied with the unit.

If your boat does not have a fuse block, the unit can be wired directly to the battery. Make sure the 2-Amp in-line fuse supplied with the unit is installed.

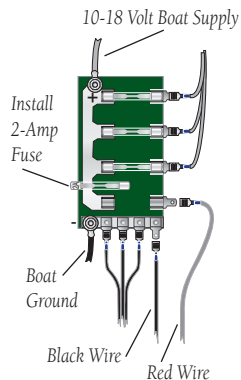

Complete information concerning NMEA formats and sentences is available for purchase from NMEA at:

NMEA
Seven Riggs Avenue
Severna Park, MD 21146
410 975-9425
410 975-9450 (fax)
www.nmea.org

Appendix G

Selecting A Transducer

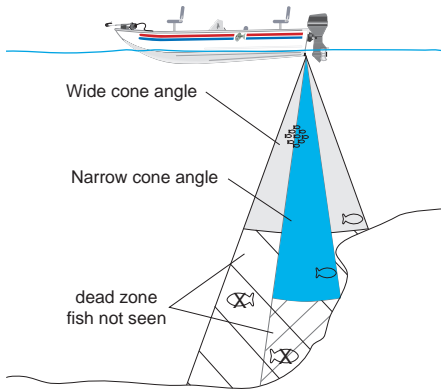

Transducers

The transducer acts as the eyes and ears of your new sonar. Proper transducer selection and installation are critical to the operation of your unit. The transducer transmits sound waves toward the bottom in a cone shape. The larger the cone angle, the larger the coverage area at a given depth. While it is good to see as large of an area as possible, it is best to select a transducer that suits the water that you are on.

A wide cone angle transducer works best in shallow water. The wide cone angle provides a large coverage area, but at a decreased bottom resolution. In deeper water this can result in a large dead zone where fish cannot be seen. A narrow cone angle transducer is better suited to deep-water installations. The narrow cone angle provides a smaller viewing area (compared to a wide cone angle transducer at the same depth) with improved bottom resolution and a smaller dead zone.

Included in the package is a 20° cone angle, temperature sensing, transom mount transducer. This transducer provides good all-around performance. Listed below are a variety of optional transducers and accessories which are available from your local dealer or GARMIN:

- 200 kHz, 20°, plastic, transom mount, depth only
- 200 kHz, 20°, plastic, transom mount, depth, temp
- 200 kHz, 20°, plastic, transom mount, depth, temp, speed
- 200 kHz, 20°, plastic, in-hull, depth only, 0° rise
- 200 kHz, 12°, bronze, thru-hull mount, depth only
- 200 kHz, 12°, bronze, thru-hull mount, depth, temp
- 200 kHz, 12°, plastic, thru-hull mount, depth only
- 200 kHz, 12°, plastic, thru-hull mount, depth, temp
- 200 kHz, 14°, plastic, trolling motor, depth, temp
- 200 kHz, 9°, bronze, thru-hull, depth, temp, speed
- 200 kHz, 8°, plastic, transom mount, depth, temp
- 200 kHz, 8°, plastic, transom mount, depth, temp, speed
- Speed Sensor
- Temperature Probe
- 10 ft. Extension cable for transducers
- 20 ft. Extension cable for transducers

Mounting the Transducer

Proper transducer installation is key to getting the best performance from your new unit. If the transducer lead is too short, extension cables are available from your GARMIN dealer. **DO NOT** cut the transducer lead or any part of the transducer cable, as this will void your warranty. The cable cannot be spliced and connected to any existing (GARMIN or non-GARMIN) transducer cables.

Following are some tips and basic installation instructions for three popular transducers. Detailed installation instructions are provided in the transducer kits. Some transducers may need to be installed by a professional marine installer.

Transom Mount Installation

Transom Mount Transducer.

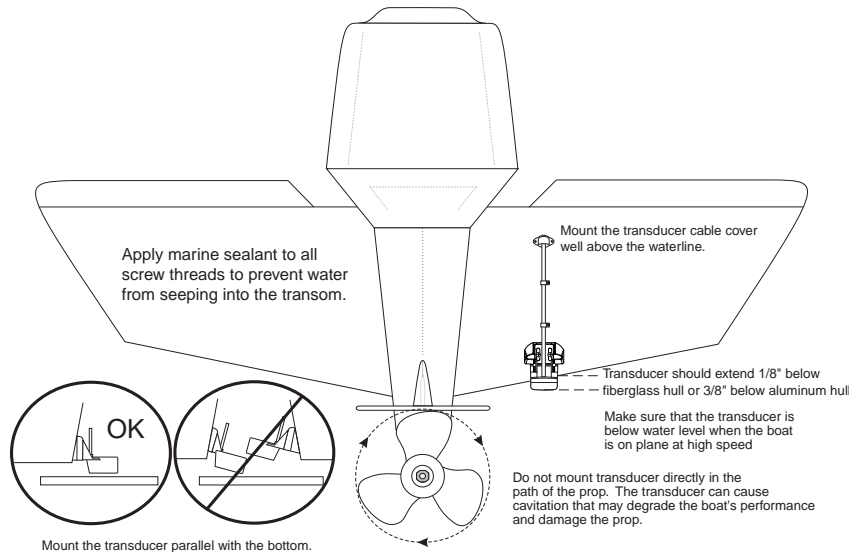

DO NOT mount the transducer behind strakes, struts, fittings, water intake or discharge ports, or anything that creates air bubbles or causes the water to become turbulent. It is important that the transducer be in clean (non-turbulent) water for optimal performance.

Appendix G

Mounting the Transducer

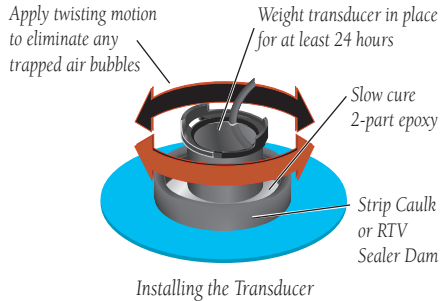
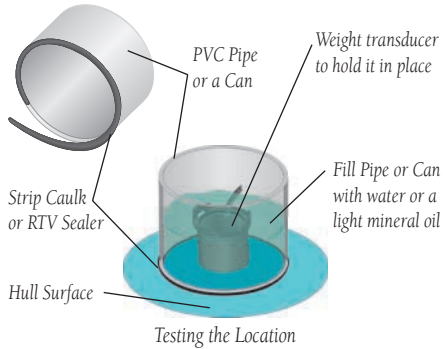

To avoid drilling a hole to mount a thru-hull transducer, a transom mount transducer may be used with epoxy inside a boat (“shoot-thru-hull” installation). For a transducer to be mounted inside the hull (shoot-thru, not thru-hull), the boat must be fiberglass, no core (contact your boat manufacturer if you are unsure). Test by placing a small amount of water inside the hull, placing the transducer on top of the water, then verifying the accuracy of the locators versus the current water depth. If they are the same, use epoxy (non-silicone based) to affix the transducer to the inside of the hull.

Shoot Thru-Hull Installation

The in-hull transducer is designed to be mounted inside a fiberglass hull. The standard plastic transom mount transducer can also be mounted in this fashion using this method. If using a temperature sensing transducer, the temperature displayed will reflect the hull temperature.

Selecting a Location:

1. The location has to be solid fiberglass, devoid of any air bubbles, laminates, fillers or dead air space. The location needs to be in an area of clean water at all speeds. Do not place the transducer over any strakes or behind any obstruction on the hull that would create turbulence at speed.



Many modern hulls have a prelocated pocket for thru-hull transducer installation. If you are unsure if your hull is equipped with a prelocated pocket, contact your hull manufacturer.

Testing the Location:

1. Place the transducer in the water, pointed directly at the bottom and set unit for optimum performance. Place the transducer in the test device as show on the side bar. If the sonar performance is significantly degraded, another location will need to be tested.

Installing the Transducer:

1. Lightly sand the surface of the hull and face of the transducer with 400 grit wet or dry sandpaper.
2. Build a dam using strip caulk about 1/4” tall. Pour about 1/8” of two part, slow cure epoxy in the dam. Place the transducer in the epoxy, turning the transducer to work out any air bubbles.
3. Weight the transducer in place and allow to cure for 24 hours.

Trolling Motor Installation

Included in the Trolling Motor transducer kit you should have:

1. Worm Gear Clamp
2. Cable Ties
3. Transducer

Mounting the Transducer:

1. Loosen the Worm Gear Clamp until the end of the band is clear of the worm gear.
2. Slide the clamp band through the slots on the transducer.
3. Place the free end of the clamp band into the worm gear and tighten until the band is through the worm gear.
4. Place the clamp and transducer over the body of the trolling motor. Finish tightening the clamp to secure the transducer to the trolling motor.
5. Secure the transducer cable to the trolling motor shaft using the supplied cable ties.



If you are experiencing interference while the trolling motor is operating, try installing the transducer cable at right angles to the trolling motor power cables.

Appendix G

Mounting the Transducer

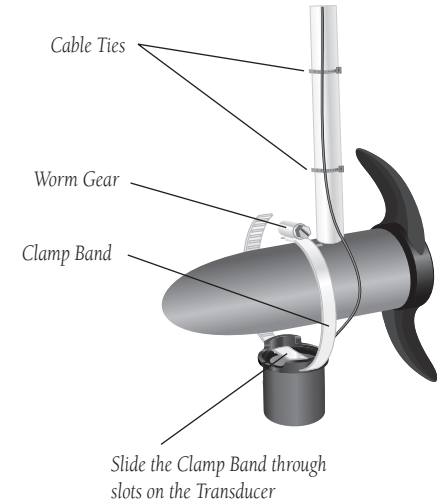

Testing the Installation

Testing the Installation

While it is possible to perform some checks with the boat trailered, the boat should be in the water to properly test the installation.

Press the **POWER** button and the GPSMAP 168 Sounder should power on. If the unit fails to power on, verify that the wiring adapter is seated properly in the back of the unit, the Red and Black wires are connected to the correct polarity, and that the 2-Amp fuse is installed and not blown. If the unit is connected to a power supply that exceeds 18 VDC, a “Battery Voltage High” warning will be displayed and the unit will turn off.

As the unit powers on, it should immediately start showing the bottom. Verify that the unit is not in the simulator mode. If the unit is in the simulator mode, make sure that the transducer is connected to the wiring harness.

To test the transducer installation, gradually increase the boat speed while checking the unit operation. If the unit displays intermittently or fails to display, verify that the transducer is aligned parallel with the bottom and if necessary, adjust the transducer height until the unit operates correctly. It may be necessary to make several adjustments to ensure proper operation throughout the speed range.



When adjusting the depth of the transducer, make the adjustments in small increments. Placing the transducer too deep can adversely affect the boat's performance and put the transducer at greater risk of striking underwater objects.

The Portable Case

The Portable Case is designed for rugged use and provides storage for the Battery Pack, the Portable Suction Cup Transducer and a mount for the GPSMAP 168 Sounder.



Use the two square eyelets located by the handle to secure the GPSMAP 168 Sounder Portable Case to the boat. The case is water resistant but is not designed to float in the event it should go overboard.

The Suction Cup Transducer

Using the Portable unit, you will still need to find a suitable location for the transducer. If you are in a slow moving boat such as a canoe or flat bottom boat, the mounting location is not as critical. Follow these simple guidelines and you should be fine.

To install the suction cup transducer mount:

1. Look for clean (non-turbulent) water.
2. Mount the transducer with approximately 1/2" extending beyond the bottom of the boat.
3. Do not mount the transducer behind strakes on the bottom of the boat or in the path of a prop.
4. If you experience poor reception, try another location.



WARNING! *Speeds in excess of 20 MPH may cause the transducer to fly off and strike occupants of the boat.*

Appendix G

GPSMAP 168 Sounder Portable

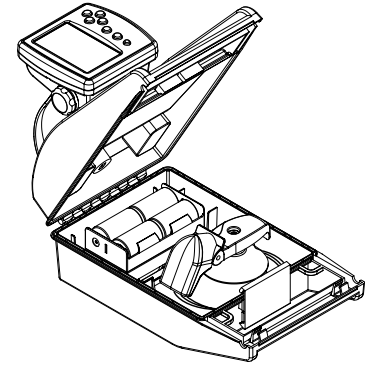

Secure the GPSMAP 168 Sounder to the boat using the provided eyelets.

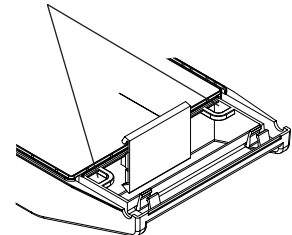

Appendix G

GPSMAP 168 Sounder Portable

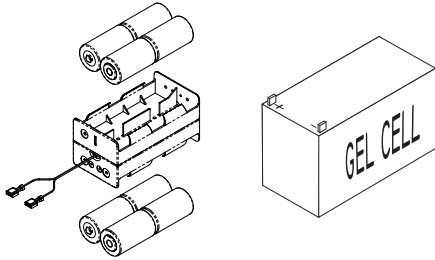

D-Cell and Optional Gel Cell Battery Packs

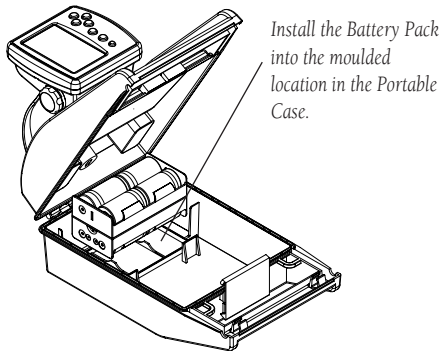

When storing the Suction Cup Transducer in the case, dry the transducer and cable to avoid corrosion. If using in Salt Water, rinse the transducer and cable in fresh water and dry before storing in the case.

Batteries

The GPSMAP 168 Sounder Portable comes with a D-Cell battery pack. Eight D-Cell Alkaline batteries will provide approximately 20 hours of continuous operation. You have the option of purchasing a 12-Volt rechargeable Gel Cell battery for the portable case from a third-party vendor. The maximum size of the Gel Cell should not exceed 4"H x 2.5"W x 6"L. If using a Gel Cell battery, you can anticipate approximately 40 hours of continuous operation between charges. Cold temperatures will reduce battery life.

Installing the D-Cell Batteries:

1. Disconnect the Red and Black leads.
2. Install the batteries noting the correct polarity.
3. Reconnect the Red and Black leads and place the battery pack (batteries down) in the provide location within the case.

Installing a Gel Cell Battery:

Verify that the Gel Cell battery has male spade connectors installed on the positive and negative leads.

1. Disconnect the Red and Black leads and remove the D-Cell battery pack.
2. Connect the Red and Black Gel Cell leads to the Red and Black wires in the portable case.
3. Place the Gel Cell battery in the same location as the D-Cell battery pack. The Portable Case was designed to accommodate a 12-Volt Gel Cell battery and hold it securely in place.

Understanding Sonar

If you are familiar with sonar, and can determine what is on the chart, this section may not be for you. This section is intended to help the novice user gain some understanding of how the GPSMAP 168 Sounder operates and how it can help improve their fishing productivity.

To understand what the unit is displaying, it is important to have a general knowledge of how the unit works and how it determines what to display. Briefly described, the unit operates by transmitting sound waves toward the bottom of a lake, stream or seabed in a cone shaped pattern. When a transmitted soundwave strikes an underwater object such as the bottom, a piece of structure, or a fish, sound is reflected back to the transducer. The transducer collects the reflected sound waves and sends the data to the unit to be processed and displayed on the chart. The underwater data is displayed on the chart in the order that it is returned: first returned—first on the chart. The diagram in the sidebar demonstrates this showing an underwater scene as it would be displayed on the chart. Generally speaking, if the only thing between the transducer and the bottom is water, the first strong return will come from the bottom directly below the transducer. The first strong return sets the bottom level. Weaker secondary returns provide the detailed data. Stronger returns will display in darker colors, black being the strongest return. In Example 2 (page 106) you can see that the branches and the fish where the strongest secondary returns are indicated in black on the display.

That is brief description of how your GPSMAP 168 Sounder operates. Let's take a look at how this data can help you to improve your fishing.

Appendix H

Understanding Sonar

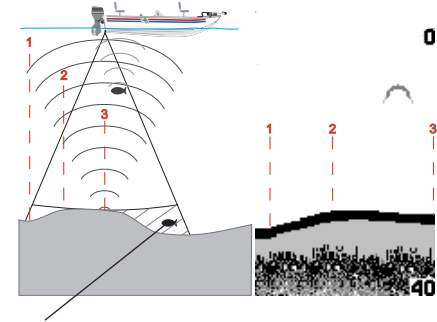

This fish is currently in a Dead Zone and is not detected by the sonar. The fish is in the coverage area of the transducer, but remember— the first strong return sets the bottom level. The fish will eventually be detected when the first strong return sets the bottom level below the fish.

Appendix H

Transducer Coverage

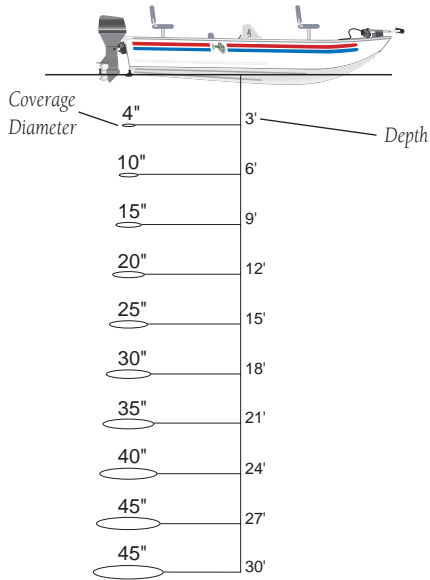

8° Transducer Coverage Chart

Transducer Coverage

The area covered by the transmitted sound waves is determined by the cone angle of the transducer and the water depth. Using GARMIN's standard 20° transducer, the coverage is approximately 1/3 of the water depth. As shown in Example 1, the coverage area at a 30-foot depth is approximately a 10-foot diameter circle. The scale below illustrates how coverage increases as depth increases.

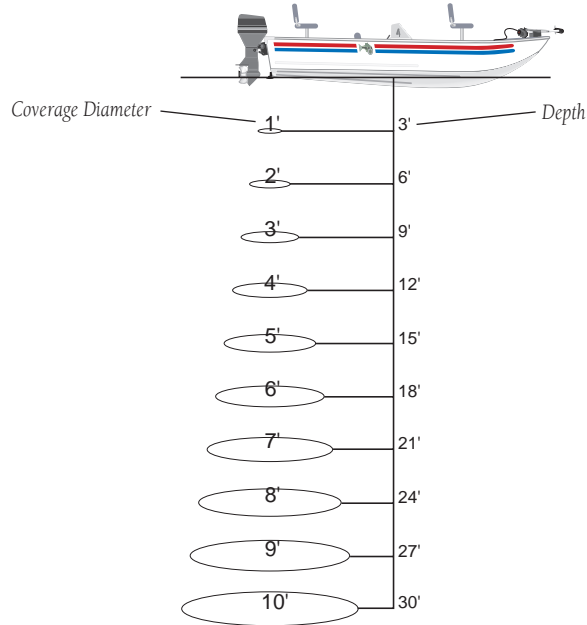

Example 1.

Understanding the Chart

It is important to understand that the unit does not display a 3-D representation of the underwater environment. The unit can display multiple things at the same time, but can not determine where the return originated— only when it was received.

Example 2 provides a look at the underwater world from a top view, and relates that view to what would be displayed on the chart. On the chart it appears the fish and tree are side by side, but when we look at the scene from the top we can see that the fish is several feet from the tree. It is important to remember that the fishfinder can not determine where in the coverage area the tree or fish are, only that the returns were received in the same time frame.

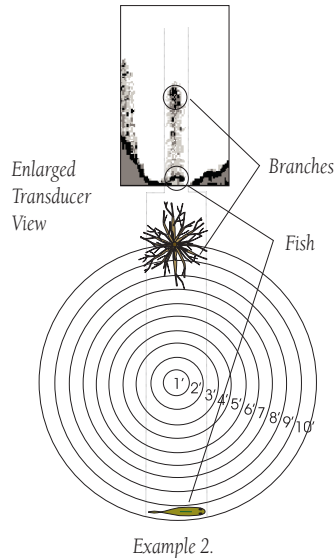

Appendix H

Understanding the Chart

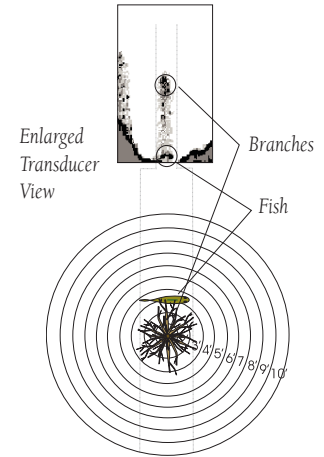

Remember that the Fishfinder displays a 2D picture of the underwater environment. The fish and tree could be located anywhere in the coverage area at that time.

Appendix H

Understanding the Chart



Whiteline can also help you to determine the type of bottom structure that is displayed on the chart. By determining the hardness of the structure, you can make a better informed decision on the type of structure.

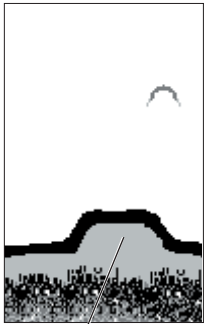

*Structure is hard—
probably a rock or stump*



*Structure is soft—
probably a mud pile*

Whiteline

The GPSMAP 168 Sounder can help you to determine if the bottom is hard or soft. When the sonar soundwaves are reflected back by the bottom, a hard bottom will return a stronger signal than a soft bottom. The stronger bottom return, the wider the bottom layer is displayed. The unit uses the whiteline function to make this bottom layer information easier to distinguish.

When viewing the display without Whiteline active, the bottom return is black. While you can make some determination of the bottom type, the black return makes this more difficult. With the whiteline active, the bottom return appears layered in shades of gray and black and makes determining the bottom type easier and more reliable. Example 3 shows the bottom return with and without the whiteline activated.

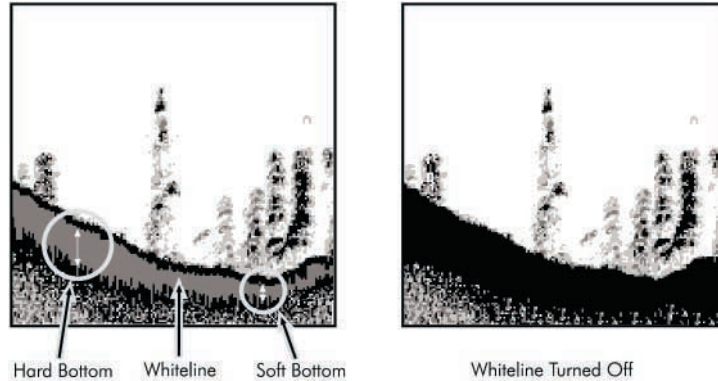

Example 3.

Understanding the Chart

Thermoclines

One of the unique features offered by GARMIN is See-Thru technology. See-Thru technology allows the GPSMAP 168 Sounder to see through thermoclines and helps locate fish where they live; and fish love the thermocline.



A rough definition of a thermocline is a break in water where the water temperature changes faster than the water above it. The thermocline usually displays as a gray level as shown below.

Thermocline

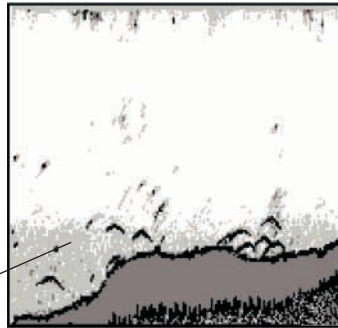

Appendix I

Advanced NMEA Setup

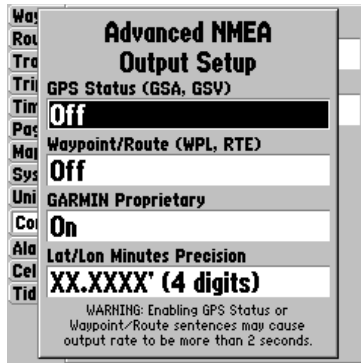

Advanced NMEA Setup Page

NMEA Interface

If you are going to interface the GPSMAP 168 Sounder with another piece of equipment such as a radar or autopilot the unit has to be set to output NMEA data. The NMEA data can be customized to shorten the update time from the unit. If too many NMEA sentences are activated the unit may take longer than 2 seconds to update.

Activating the NMEA Data:

1. With the GPSMAP 168 Sounder turned on, press the **MENU** key twice to display the Main Menu. Using the Arrow Keypad, select the 'COMM' tab.
2. Highlight the 'Serial Data Format' field and press **ENTER**.
3. Select 'NMEA IN/NMEA OUT' and press **ENTER**.

Advanced NMEA Output Setup

The GPSMAP 168 Sounder NMEA data transmission can be customized to keep the output rate at two seconds. If the unit is set up to output all of the available NMEA sentences, the output rate may exceed two seconds. The 'Advanced NMEA Output Setup' page will allow you to turn On/Off the GPS Status (GSA, GSV), Waypoint/Route (WPL, RTE) and the GARMIN Proprietary sentences. You can also change the precision of the Lat/Lon Minutes.

Advanced NMEA Output Setup:

1. With NMEA In/NMEA Out selected, press the **MENU** key. Select NMEA Setup and press **ENTER**.
2. To turn a field On/Off, place the highlight over that field and press **ENTER**. Make a selection and press **ENTER** again to accept the selection.

GPSMAP 168 Sounder NMEA Sentence Output (NMEA Version 2.30 compliant)

Always transmitted:

GPRMC, GPGGA, GPGLL, GPBOD, GPBWC, GPVTG, GPXTE, GPRMB

Switchable sentences:

GPGSA, GPGSV, GPWPL, GPRTE

GARMIN Proprietary:

PGRME, PGRMZ, PGRMM

Index

- A**
- Accessoriesviii, 96
 - Accuracy21
 - Accuracy Circle34
 - Active Route Page47, 68
 - Active Route Page Options68
 - Adjustment Bar14, 38-39
 - Alarms78-79
 - Anchor Drag Alarm78
 - Arrival Alarm78
 - ARROW KEYPAD1
- B**
- Backlighting6-7
 - Battery Alarm78
 - Bearing Line34
 - Bearing/Distance Measuring31
 - Beeper73
- C**
- Capabilitiesvii
 - Cautionsiii
 - Celestial Tab80
 - Clock Alarm78
 - Compass Page16,45
 - Compass Page Options45
 - Contrast Setting6
 - Course Line34
 - Cursor Movement9, 25-26
- D**
- Data Entry2-3
 - Data Fields, Changing36-37
 - Data Transfer76
 - Date/Time20, 72
 - Datum, Map74, 88-89
 - Daylight Savings Time72
 - Deep Water Alarm78
 - Depth Line14, 38,39,41
 - Depth Scale14, 38,43
 - Depth Units75
 - DGPS Interface Settings76-78
 - DGPS Status20-22, 77
 - Dilution Of Precision (DOP)21
 - Distance, Speed and Elevation.....71
- E**
- ENTER/MARK Key1, 48
- F**
- Factory Setup73
 - Fish Alarm78
 - Fish Symbols42
 - Flasher14, 31,38,41
 - Follow Track58-59
 - Follow Route12, 63
 - Fuel Flow67
 - Full Screen Map30
- G**
- Gain39
 - Go To Waypoint54,56-57
 - Going to a Destination11, 56
- H**
- Heading75
 - Heading Line.....34
 - Highway Page16-18, 46
 - Highway Page Configuration47
 - Highway Page Options46-47
 - “How To” Indexix
- I**
- IN Key1
 - Initialization4-5, 21
 - Installation93-102
 - Interface Formats76
 - Interfacing76-95

Appendix J

Index

J

Jump To Page72

K

Keel Offset43

Keypad Usage1

L

Land Mode33

Language Selection73

Layout35-36

Loran TD83-84

M

Magnetic Variation75

Main Menu69-82

Main Menu Page69

Map Configuration32-34

Map Datums70, 88-89

Map Page8-9, 24-37

Map Page Options30-37

Map Scales29

Map, Zooming9, 29

MapSource Info Page35

Measure Distance/Bearing31

MENU Key1

Messages86-87

MOB60

Moonrise/Moonset80

N

NAV/MOB Key1, 11-12, 56-57,
59-60, 63

Navigation Terms90-91

Nearest Tide Station82

Nearest Waypoint List54

NMEA Output Formats76,95

Noise Reject43

O

Odometers, Trip72

Off Course Alarm78

Options, Selecting2

OUT Key1

Overzoom29

P

Packing Listviii

PAGE Key1

Pages Tab72

Plan Route67

Portable Case101-102

Position Format74

Power Off19

Power On4, 6

Power/Backlight/Contrast Key1

Prefaceii

Proximity Waypoints54-56

Q

QUIT Key1

R

Receiver Status21-22

Registrationii

Remember Settings43

Restore GARMIN Setup73

Route List Page63

Route Review Page64

Routes61-68

Routes- Activating12, 63

Routes- Copying63

Routes- Creating61-62

Routes- Deactivating63

Routes- Deleting63-67

Routes- Editing64-67

Routes- Insert/Add Turns & Points ...65-66

Index

Routes- Inverting	67
Routes- Naming	64
Routes- Plan Route	67
Routes- Removing Points	65,66
Routes- Reviewing Points	64,65

S

Satellite Sky View	5, 20
Scroll Speed	42
Serial Data Format	76
Serial Number	iv
Shallow Water Alarm	78
Signal Strength Bars	5, 20
Simulator	7, 73
Software Version	73
Sonar Configuration	38-40
Sonar Page	8, 14-15, 38-44
Sonar Page Options	40-44
Sonar, Understanding	103-107
Sonar Zoom	15, 38-39
Specifications	92
Speed, Distance and Elevation	75
Speed Filter	73
Split Screen, Resizing	31-32,41
Status Page	5-8, 20-23
Status Page Options	22-23
Sunrise/Sunset	80

Symbols, Waypoint	10, 13, 48-51
System Mode	73

T

Table of Contents	x
Temperature	75
Thermoclines	14, 38, 107
Tide Charts	81-82
Tide Page Settings	81-82
Time, Daylight Savings	72
Time Format	72
Time Offsets	85
Time Zone	72
TracBack	58-59, 67
Track Log- Clearing	19, 58,71
Track Log- Deleting	71
Track Log- Displaying	33,47,59
Track Log- Saving	58,71
Track Log- Showing on Map	33,47,59,71
Track Setup	70-71
Transducers	96-100
Trip and Fuel Planning	67
Trip Odometers	72
Trip Timers	72

U

Units Setting	74-75
User Datum	74,88-89

W

WAAS	23
Warnings	iii
Warranty	vi
Water Mode	33
Water Speed, Calibrating	43-44
Water Type	43
Waypoint Lists	52-56
Waypoint Options	51-53
Waypoints- Creating	28-29,48-50
Waypoints- Deleting	53
Waypoints- Editing	50-53
Waypoints- Moving	51
Waypoints- Naming	51
Waypoints- Nearest	54
Waypoints- Proximity	54-56
Waypoints- Reviewing	50-51
Welcome Page	4
Whiteline	14,38,42,107
Wiring Installation	95

Z

Zooming	9, 15, 24, 29,39,46
---------------	---------------------



© 2000 - 2002 GARMIN Corporation

GARMIN International, Inc.
1200 East 151st Street, Olathe, Kansas 66062, U.S.A.

GARMIN (Europe) Ltd.
Unit 5, The Quadrangle, Abbey Park Industrial Estate, Romsey, SO51 9AQ, U.K.

GARMIN Corporation
No. 68, Jangshu 2nd Road, Shijr, Taipei County, Taiwan

www.garmin.com

Part Number 190-00170-00 Rev. D