



## GPSMAP® 3000 Series Installation Supplement for GPS 17N or GPS 17HVS™ Antennas

The Installation Instructions included with your GPSMAP 3000 series chartplotter contain instructions for mounting a GPS 17x antenna. This supplement contains instructions for mounting a GPS 17N or GPS 17HVS antenna. Check the label on your antenna to determine which model you have. Refer to the *GPSMAP 3000 Series Installation Instructions* to install cabling and for additional installation instructions.

### Installing the GPS 17N or GPS 17HVS

The GPS 17N/17HVS can be flush mounted or installed on any standard 1" O.D. (Outer Dimension), 14 threads-per-inch, marine mount. When mounting the antenna, the cable can be run externally, through the mounting panel, or through the center of the marine mount.

The GPS 17N/17HVS connects to the 18-pin Power/Data cable on the GPSMAP 3000 series chartplotter and provides the GPS/WAAS signal for the unit. If two or more GPSMAP 3000 series units are installed and networked, only one GPS 17N or GPS 17HVS needs to be installed.

For optimal reception, mount the GPS 17N/17HVS in a location that has a clear, unobstructed view of the sky in all directions. Avoid mounting the antenna where it is shaded by the superstructure of the boat, a radome antenna, or mast. Avoid mounting the unit high on a sailboat mast to prevent inaccurate speed readings caused by excessive heeling. The unit provides more stable readings if it is located nearer to water level. **Mount the GPS 17N/17HVS at least 3 ft. (9 m) away from (preferably above) the path of any radar beam or a VHF radio antenna.** Temporarily secure the unit in the preferred mounting location and test for correct operation. After verification, permanently mount the unit. If interference with other electronics is experienced, try a different location.

**NOTE:** Do not paint the GPS 17N/17HVS antenna or clean it with harsh solvents.

#### To flush mount the GPS 17N/17HVS:

1. Cut out the Flush Mount Template on [page 3](#), and tape it on the selected mounting location.
2. Mark the center of each mounting hole by tapping the end of a center punch or pointed object with a hammer. If the cable is going to be installed through the mounting panel, mark the center of the additional hole.
3. Drill the holes using the appropriate drill bits.
4. Align the GPS 17N/17HVS over the mounting holes, and fasten it using M4 screws. The mounting threads are 8.1 mm deep. Do not use screws that thread into the antenna deeper than 5/16 in. (8 mm), or the case may be damaged.

*The antenna can be installed with the coax through the panel or on the outside of the unit. If the coax is run through the panel, seal the outside exit area with marine sealant.*



**NOTE:** Mount the antenna at least 3 ft. (0.9 m) away from (preferably above) the path of any radar beam or a VHF radio antenna.

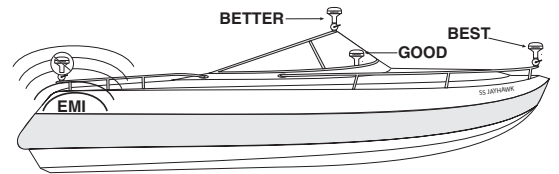

*EMI (Electromagnetic Interference)  
from engine components*

**Signal Interference**

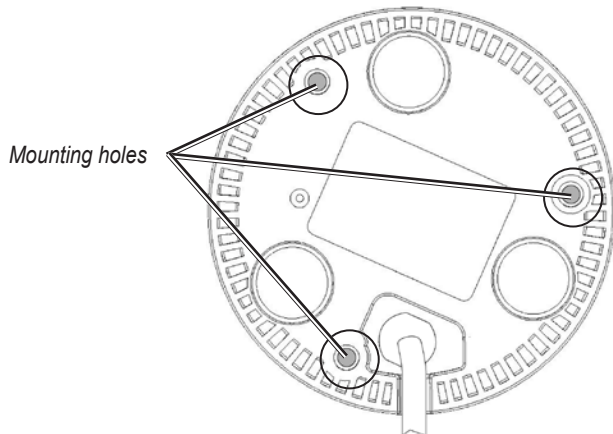

**Bottom of GPS 17N/17HVS**

**To attach the enclosed pole mount to the GPS 17N/17HVS:**

1. Thread the cable through the pole mount.
2. Align the tab on the mount to the notch on the antenna.
3. Use the enclosed screws to secure the mount to the base.

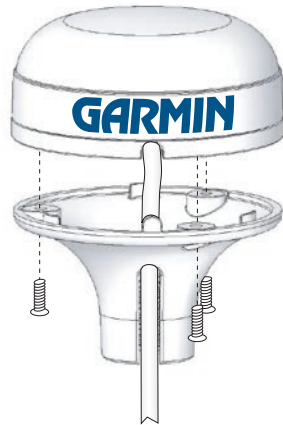

**Attaching the Pole Mount to the Antenna**

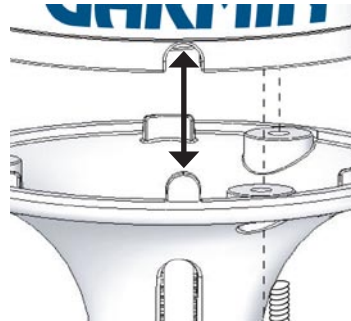

**Align Notch**

**To mount the GPS 17N/17HVS with the cable run outside the mount:**

1. Place the cable in the vertical slot along the side of the base of the unit.
2. Screw the antenna onto the mount. DO NOT over-tighten the head. It is possible to over-tighten the unit and cut the cable.
3. With the antenna and mount installed, fill the remaining gap in the cable exit with a marine sealant.
4. Route the cable away from sources of electronic interference.

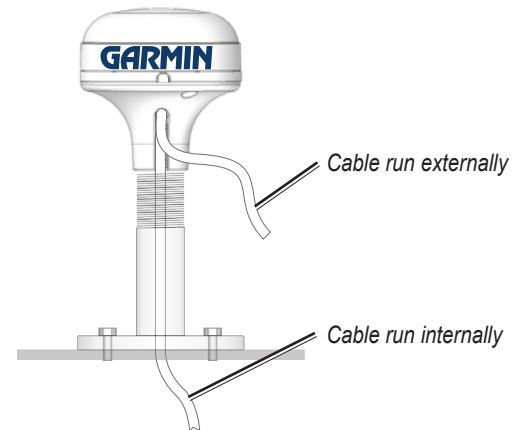

**Attaching the GPS 17N/17HVS to a Pole Mount**

**To mount the GPS 17N/17HVS with the cable run through the mount:**

1. Position the mount in the preferred location, and mark the approximate center of the mount.
2. Drill a hole large enough for the cable to pass through.
3. Slide the cable through the mount and screw the antenna onto the mount.
4. Fasten the mount to the boat.
5. Route the cable away from sources of electronic interference.

**Power/Data Cable Wiring**

Use the following diagram to connect the GPS 17N/17HVS antenna to a GPSMAP 3000 series chartplotter. Use 22 AWG (18 AWG for the Red and Black wires), shielded, twisted-pair wiring for extended runs of wire. Solder all connections and seal the connection with heat shrink tubing.

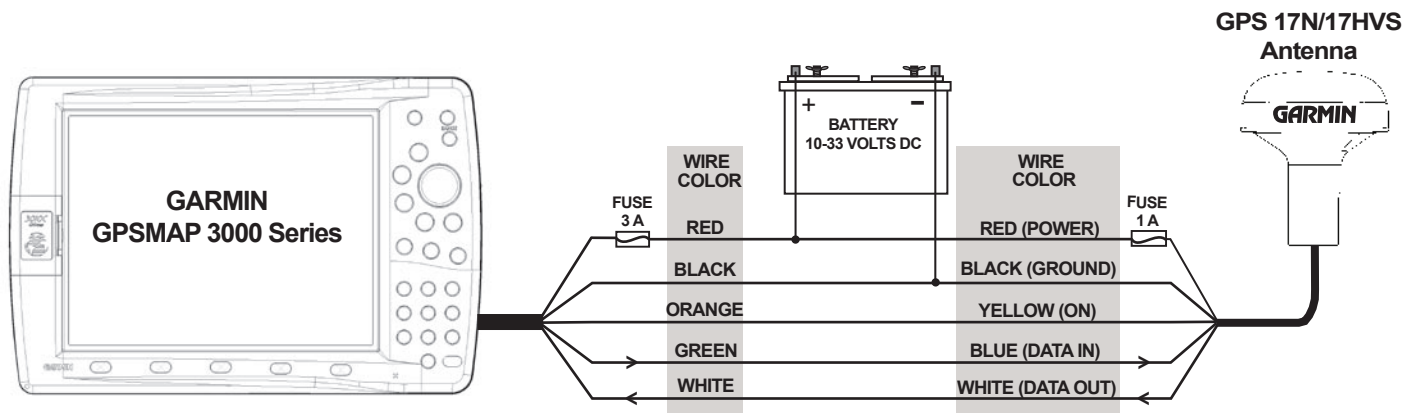

## GPS 17N and GPS 17HVS Flush-Mount Template

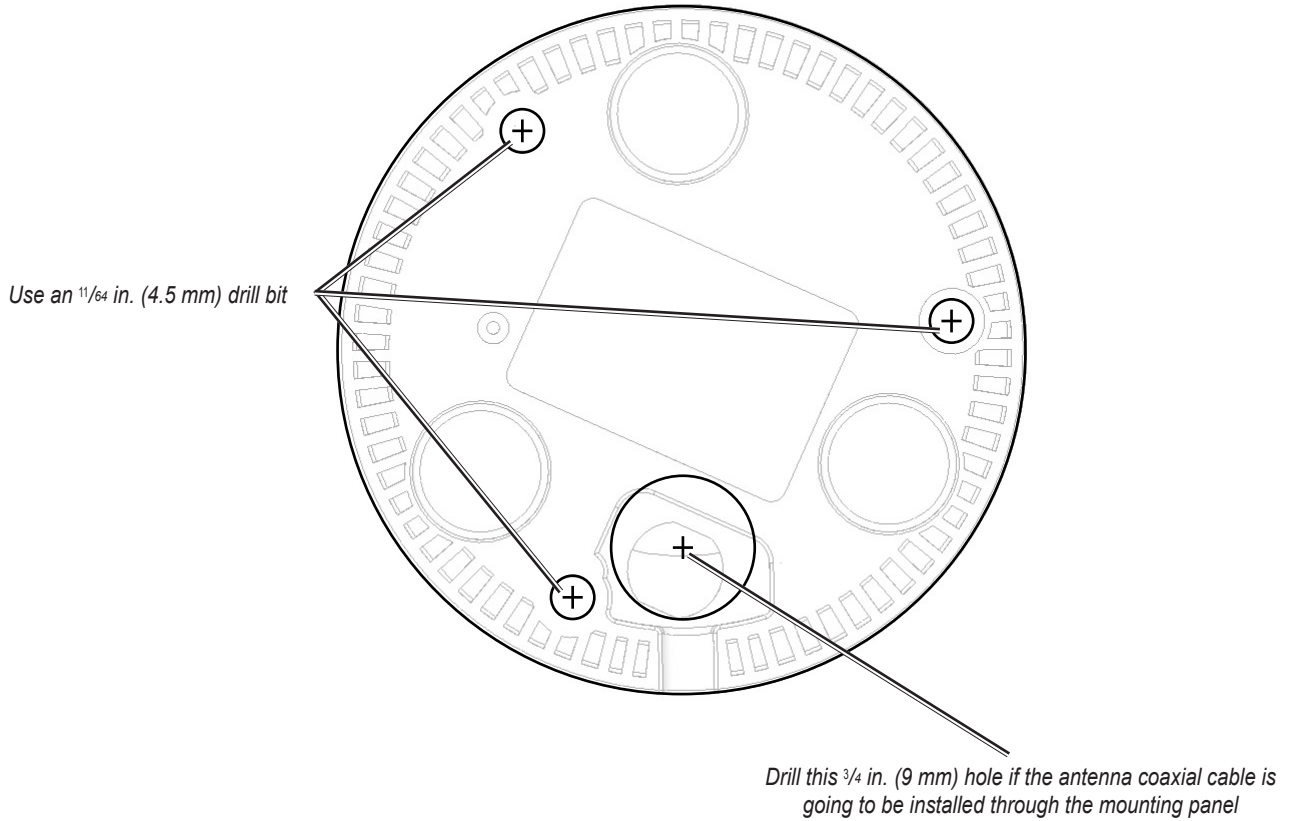



© 2008 Garmin Ltd. or its subsidiaries

Garmin International, Inc.  
1200 East 151<sup>st</sup> Street, Olathe, Kansas 66062, USA

Garmin (Europe) Ltd.  
Liberty House, Hounslow Business Park, Southampton, Hampshire, SO40 9RB UK

Garmin Corporation  
No. 68, Jangshu 2nd Road, Shijr, Taipei County, Taiwan

[www.garmin.com](http://www.garmin.com)