



## GPSMAP® 6000/7000 Series Installation Instructions

### ⚠ WARNING

See the *Important Safety and Product Information* guide in the product box for product warnings and other important information.

### ⚠ CAUTION

Always wear safety goggles, ear protection, and a dust mask when drilling, cutting, or sanding.

### NOTICE

When drilling or cutting, always check what is on the opposite side of the surface to avoid damaging your boat.

The GPSMAP 6000/7000 series chartplotter and GPS antenna must be properly installed according to the following instructions. You need the appropriate fasteners, tools, and mounts listed in each section. These items are available at most marine dealers.

Contact Garmin® Product Support if you have any questions while installing your GPSMAP 6000/7000 series chartplotter. In the USA, go to [www.garmin.com/support](http://www.garmin.com/support), or contact Garmin USA by phone at (913) 397.8200 or (800) 800.1020. In the UK, contact Garmin (Europe) Ltd. by phone at 0808 2380000. In Europe, go to [www.garmin.com/support](http://www.garmin.com/support) and click **Contact Support** for in-country support information, or contact Garmin (Europe) Ltd. by phone at +44 (0) 870.8501241.

Before installing your GPSMAP 6000/7000 series chartplotter, confirm that the package contains the items listed on the box. If any parts are missing, contact your Garmin dealer immediately.

## Product Registration

Help us better support you by completing our online registration today. Go to <http://my.garmin.com>. Keep the original sales receipt, or a photocopy, in a safe place.

For future reference, write the serial numbers assigned to your GPSMAP 6000/7000 series chartplotter and GPS antenna in the space provided. The serial numbers are located on a sticker on the back of each device.

**Chartplotter serial number:** \_\_\_\_\_

**GPS antenna serial number:** \_\_\_\_\_

### To install the GPSMAP 6000/7000 series chartplotter, you must:

1. Mount the GPSMAP 6000/7000 series chartplotter ([page 2](#)).
2. Mount the GPS antenna ([page 4](#)).
3. Connect the GPSMAP 6000/7000 series chartplotter to power ([page 7](#)).
4. Connect the GPSMAP 6000/7000 series chartplotter and the GPS antenna to an existing NMEA 2000 network or create a simple NMEA 2000 network ([page 8](#)).
5. Ensure that the chartplotter software is up-to-date ([page 17](#)).

### The following additional installation options are not necessary in order to use the GPSMAP 6000/7000 chartplotter. They have been included for your convenience:

- Connecting the chartplotter to other Garmin Marine Network compatible devices, such as a sounder or a radar ([page 9](#)).
- Connecting the chartplotter to a GPS 17 or GPS 17 HVS antenna ([page 15](#)).
- Connecting the chartplotter to other NMEA 0183-compatible devices such as a VHF radio with DSC ([page 12](#)).
- Connecting the chartplotter to an external alarm ([page 15](#)).
- Connecting the chartplotter to a video input source, to a PC, or to an external video monitor ([page 16](#)).

## Mounting the GPSMAP 6000/7000 Series Chartplotter

You can mount the GPSMAP 6000/7000 series chartplotters using one of two methods. You can use the included bracket to bail mount the chartplotter, or you can use the included template and hardware to flush mount the chartplotter.

Mount the GPSMAP 6000/7000 series chartplotter in a location that provides a clear, glare-free view of the display and easy operation of the controls or touch screen.

**NOTE:** You cannot bail mount the GPSMAP 7015/7215 chartplotters. Because of the larger size of these devices, you must flush mount a GPSMAP 7015 or a GPSMAP 7215 chartplotter.

## Bail Mounting the GPSMAP 6000/7000 Series Chartplotter

Use the included bracket to bail mount a GPSMAP 6008, 6208, 6012, 6212, 7012, or a GPSMAP 7212 chartplotter.

### Tools required (not included):

- Drill and drill bits
- Pencil
- Mounting hardware (screws or nuts, washers, and bolts)

**NOTE:** The bail-mounting hardware (screws or nuts, washers, and bolts) is not included. The holes on the bail mount are  $\frac{5}{16}$  in. (7.9 mm) in diameter. Choose mounting hardware that fits the holes in the bail mount and securely attaches it to your specific mounting surface. The size of the drill bit required depends on the mounting hardware you use.

### To install the bail-mount bracket:

**Note:** You cannot bail mount the GPSMAP 7015/7215 chartplotters. Because of the larger size of these devices, you must flush mount a GPSMAP 7015 or a GPSMAP 7215 chartplotter.

1. Using the bail mount as a template, mark the location of the four mounting holes. Be sure to leave at least 5 in. (12.7 cm) of clearance behind the 6000/7000 series chartplotter for the wiring.

**NOTE:** To avoid interference, mount GPSMAP 6008/6208 chartplotters 15 in. (38.1 cm), GPSMAP 6012/6212 chartplotters 16 in. (40.6 cm), and GPSMAP 7012/7212 chartplotters 25 in. (63.5 cm) from a magnetic compass.

2. Using an appropriately-sized drill bit, drill the pilot holes for your mounting hardware.
3. Secure the bail mount to the surface with screws and washers.

### To install the GPSMAP 6000/7000 series chartplotter on the bail-mount bracket:

1. Loosely attach the mounting knobs to the GPSMAP 6000/7000 series chartplotter.
2. Slide the chartplotter onto the bail mount, and tighten the mounting knobs.

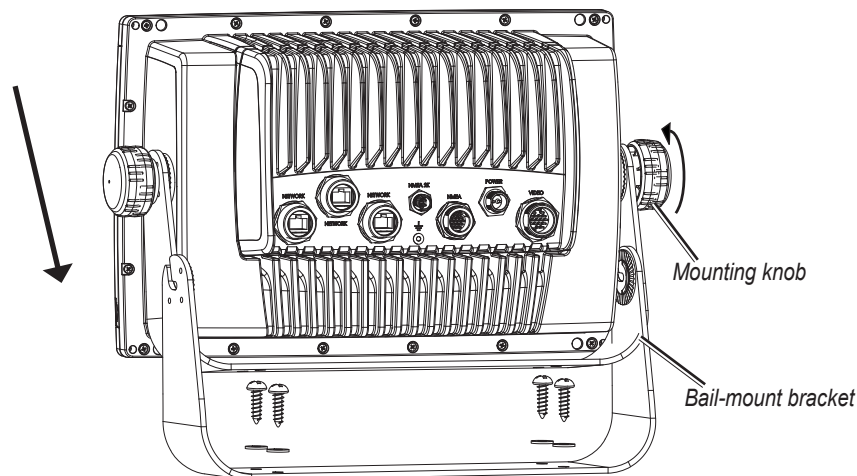

**Installing a GPSMAP 6000/7000 Series Chartplotter on the Bail-mount Bracket**

## Flush Mounting the GPSMAP 6000/7000 Series Chartplotter

### Hardware (included):

- Flush-mount template
- Rubber gasket
- Four flush-mount nut-plates
- Four 60 mm M3 × 0.5 screws (to secure the nut plate to the mounting surface)
- Four M4 × 0.7 screws (to secure the chartplotter to the nut plate)
- Four 7 mm nylon washers (for the M4 × 0.7 screws)

### Tools required (not included):

- Jigsaw
- Scissors
- Drill
- Drill bits— $\frac{3}{8}$  in. (9.5 mm),  $\frac{9}{32}$  in. (7.2 mm), and  $\frac{9}{64}$  in. (3.5 mm)
- Number 2 Phillips screwdriver
- Center punch and hammer
- File and sandpaper

1. The flush-mount template is included in the product box. Trim the template and ensure that it will fit in the location at which you want to flush mount the chartplotter.

### NOTES:

- Ensure that the surface on which you mount the chartplotter has enough open space behind it to accommodate the chartplotter and the connected wires. Refer to the diagram on the flush-mount template for the clearance-space needed by your chartplotter.
  - Ensure that there is at least  $\frac{1}{2}$  in. (13 mm) of space on the right side of the chartplotter to access the SD card door, as indicated on the flush-mount template.
  - Ensure that enough ventilation is present behind the mounting surface to create sufficient air flow to prevent the chartplotter from overheating.
  - To avoid interference, mount GPSMAP 6008/6208 chartplotters 15 in. (38.1 cm), GPSMAP 6012/6212 chartplotters 16 in. (40.6 cm), GPSMAP 7012/7212 chartplotters 25 in. (63.5 cm) and 7015/7215 chartplotters 17 in. (43.2 cm) from a magnetic compass.
2. The flush-mount template has adhesive on the back. Remove the protective liner and apply the template to the location at which you want to flush mount the chartplotter.
  3. Using a  $\frac{3}{8}$  in. (9.5 mm) drill bit, drill one or more of the four pilot holes inside the corner of the template to begin cutting the mounting surface.
  4. Using a jigsaw, cut the mounting surface along the inside of the solid line indicated on the flush-mount template. Use a file and sandpaper to refine the size of the hole. **Be very careful when cutting this hole. There is only a small amount of clearance between the case and the mounting holes.**
  5. Place the chartplotter in the hole and ensure that the mounting holes on the chartplotter line up with the larger  $\frac{9}{32}$  in. (7.2 mm) holes on the flush-mount template after cutting, sanding, and filing the hole. If they do not line up, mark new locations for the larger holes.
  6. Using a center punch, indent the center of each of the larger  $\frac{9}{32}$  in. (7.2 mm) mounting-hole locations.
  7. Using a  $\frac{9}{32}$  in. (7.2 mm) drill bit, drill the four larger holes.
  8. Starting in one corner of the template, place a nut plate over the larger hole you drilled in step 7. Ensure that the smaller  $\frac{9}{64}$  in. (3.5 mm) hole on the nut plate lines up with the smaller hole on the template. If they do not line up, mark a new location for the smaller hole. Repeat this step for each corner of the template.
  9. Using a center punch, indent the center of each of the smaller  $\frac{9}{64}$  in. (3.5 mm) mounting-hole locations.
  10. Remove the flush-mount template from the mounting surface.
  11. Starting in one corner of the mounting location, place a nut plate on the back of the mounting surface, lining up the large and small holes. The raised portion of the nut plate should fit into the larger hole.
  12. Secure the nut plate to the mounting surface by fastening an included 60 mm M3 × 0.5 screw through the smaller  $\frac{9}{64}$  in. (3.5 mm) hole.

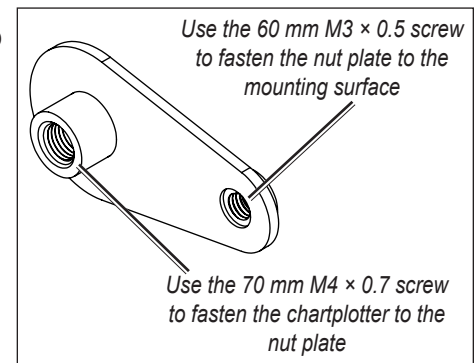

**Flush-mount Nut Plate**

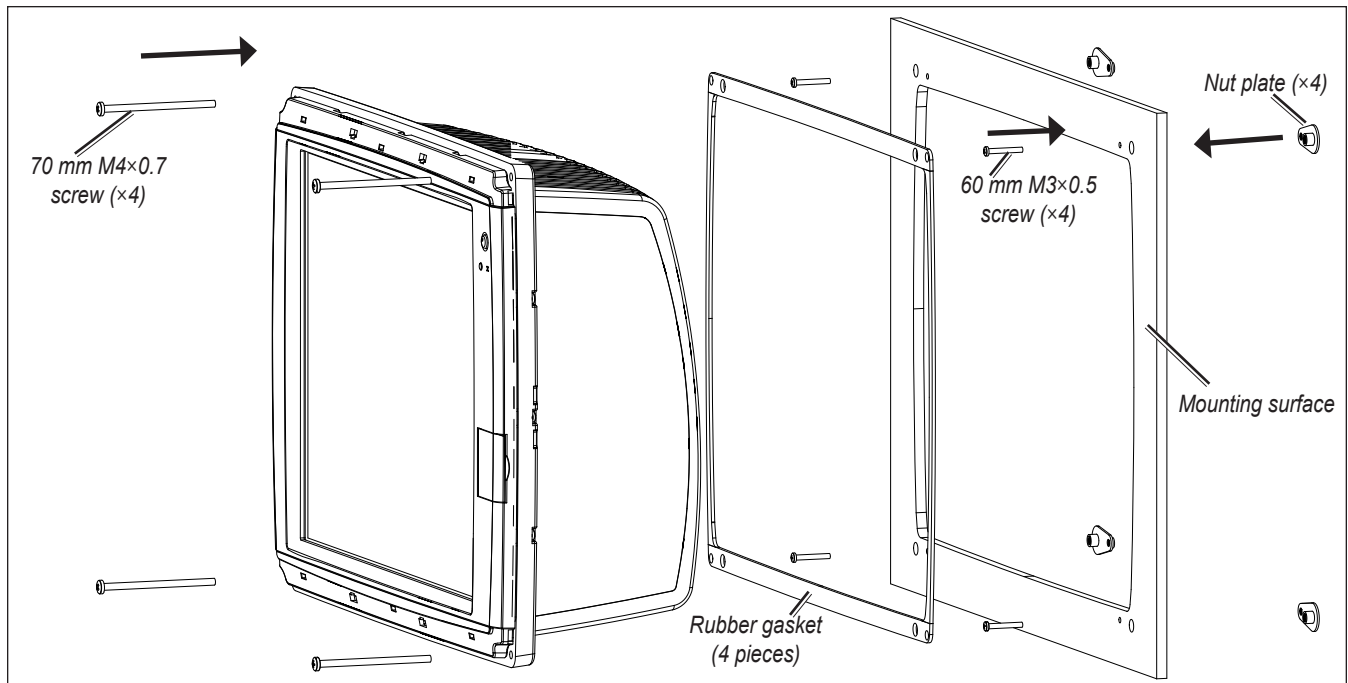

### Flush-mounting a GPSMAP 6000 or 7000 Series Chartplotter

13. Repeat steps 11–12 for each nut plate on the remaining three corners of the mounting surface.
14. Install the rubber gasket on the back of the chartplotter. The top and bottom sections line up with the holes.
15. If you will not have access to the back of the chartplotter after you mount it, connect all necessary cables to the chartplotter before placing it into the cutout.
16. Place the chartplotter into the cutout.
17. Secure the chartplotter to the mounting surface using the included 70 mm M4 × 0.7 screws and 7 mm black nylon washers.
18. Install the mounting covers by snapping them into place.

**NOTE:** To prevent corrosion of the metal contacts, cover unused connectors (page 17) with the attached weather caps.

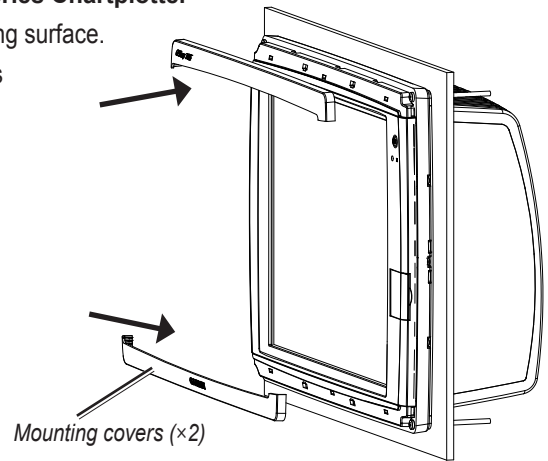

### Mounting the GPS Antenna

You can surface mount the GPS antenna, attach it to a standard 1 in. OD pipe-threaded-pole marine mount (14 threads-per-inch—not included), or install the antenna under fiberglass.

Select a suitable location for the GPS antenna on your boat. To ensure the best reception, mount the GPS antenna in a location that has a clear, unobstructed view of the sky in all directions.

- Avoid mounting the GPS antenna where it is shaded by the superstructure of the boat, a radome antenna, or a mast.
- On a sailboat, avoid mounting the GPS antenna high on the mast to prevent inaccurate speed readings caused by excessive heeling.
- The GPS antenna provides more-stable readings when located nearer to water level.
- **Mount the GPS antenna at least 3 ft. (1 m) away from (preferably above) the path of any radar beam or a VHF radio antenna.**

Temporarily secure the antenna in the preferred mounting location and test it for correct operation. If you experience interference with other electronics, try a different location. After you verify correct operation, permanently mount the antenna.

#### Tools required (not included):

- Drill and drill bits
- Screwdrivers
- Marine sealant (optional)

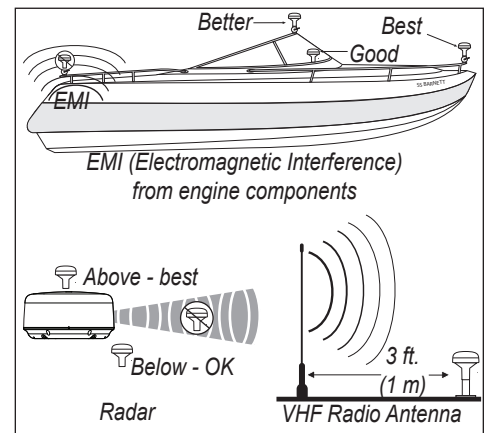

#### GPS Antenna Placement Considerations

## Surface-mounting the GPS Antenna

1. Use the surface-mount bracket as your mounting template, using the following steps:

- Use a center punch to mark the three screw locations on the surface.
- Use a pencil to trace the cable-hole in the center of the bracket.
- Set the surface-mount bracket aside. Do not drill through the surface-mount bracket.

2. Drill  $\frac{1}{8}$  in. (3 mm) pilot holes at the three marked locations.

**NOTE:** If you are mounting the GPS antenna on fiberglass, it is recommended to use a countersink bit to drill a clearance counterbore through the top gelcoat layer (but no deeper). This will help to avoid cracking in the gelcoat layer when the screws are tightened.

3. Use a 1 in. (25 mm) hole saw to cut the cable hole in the center.

4. Place the seal pad on the bottom of the surface-mount bracket. Make sure that the screw holes align.

5. Use the included M4 screws to attach the surface-mount bracket to the mounting surface.

6. Route the NMEA 2000 cable through the 1 in. (25 mm) cable hole and connect it to the GPS antenna.

7. Make sure the large gasket is in place on the bottom of the GPS antenna, place the antenna on the surface-mount bracket **1**, and twist it clockwise to lock it in place **2**.

8. Secure the antenna to the mounting bracket with the included M3 set screw **3**.

9. Route the NMEA 2000 drop cable away from sources of electronic interference, and connect it to your NMEA 2000 network ([page 8](#)).

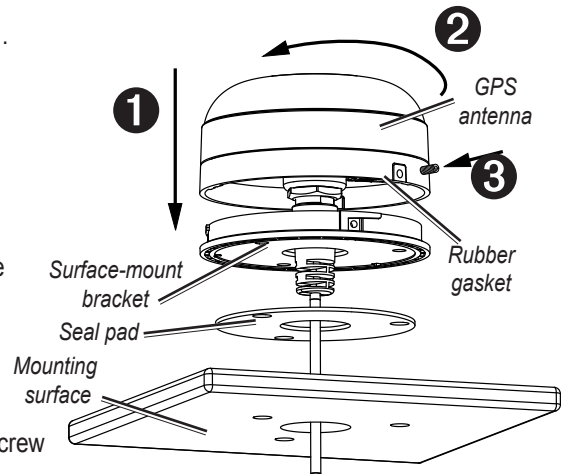

## Pole Mounting the GPS Antenna

With the pole-mount adapter attached to the GPS antenna, you can install it on a standard 1 in. OD pipe-threaded-pole marine mount (14 threads per inch—not included). You can run the NMEA 2000 cable through the pole or outside the pole.

### To mount the GPS antenna with the cable run outside the pole:

1. Route the NMEA 2000 drop cable through the pole-mount adapter, and place the cable in the vertical slot along the base of the pole-mount adapter.

2. Thread the pole-mount adapter onto a standard 1 in. OD pipe-threaded-pole marine mount (14 threads per inch—not included). Do not overtighten the adapter.

3. Connect a NMEA 2000 drop cable to the GPS antenna.

4. Place the GPS antenna on the pole-mount adapter **1** and twist it clockwise to lock it in place **2**.

5. Secure the antenna to the adapter with the included M3 set screw **3**.

6. (Optional) With the GPS antenna installed on the pole mount, fill the remaining gap in the vertical cable slot with a marine sealant.

7. Attach the marine mount to the boat if it is not already attached.

8. Route the cable away from sources of electronic interference, and connect it to your NMEA 2000 network ([page 8](#)).

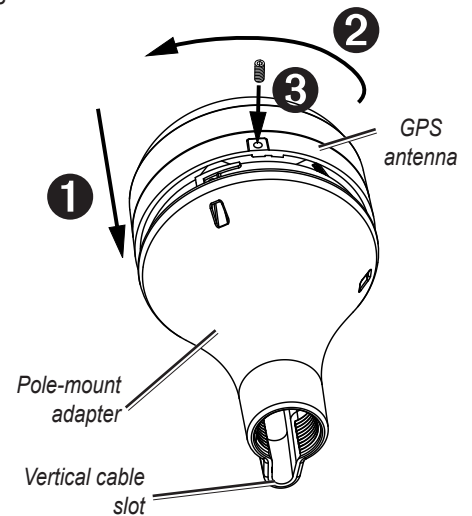

### To mount the GPS antenna with the cable run through the pole:

1. Position a standard 1 in. OD pipe-threaded-pole marine mount (14 threads per inch—not included) in the preferred location, and mark the approximate center of the pole.

2. Drill a hole using a  $\frac{3}{4}$  in. (19 mm) drill bit for the cable to pass through.

3. Fasten the marine mount to the boat.

4. Thread the pole-mount adapter onto the pole. Do not overtighten the adapter.

5. Route a NMEA 2000 drop cable through the pole and connect it to the GPS antenna.

6. Place the GPS 19x antenna on the pole-mount adapter **1** and twist it clockwise to lock it in place **2**.

7. Secure the antenna to the adapter with the included M3 set screw **3**.

8. (Optional) With the GPS 19x installed on the pole mount, fill the vertical cable slot with a marine sealant.

9. Route the NMEA 2000 drop cable away from sources of electronic interference, and connect it to your NMEA 2000 network ([page 8](#)).

## Under-deck-mounting the GPS 19x Antenna

The GPS 19x antenna can be mounted under a fiberglass surface with the adhesive pads attached to the under-deck mounting bracket. The GPS 19x will not acquire satellite signals through metal—you can only use the under-deck mount under a fiberglass surface.

1. Determine the location on the fiberglass surface where you want to mount the GPS 19x.
2. Place the adhesive pads on the under-deck mounting bracket.
3. Place the GPS 19x in the under-deck mounting bracket.
4. Adhere the under-deck mounting bracket to the mounting surface.
5. Secure the under-deck mount to the mounting surface with screws. Use extreme care to ensure that the screws do not penetrate the upper surface of the deck.
6. Connect a NMEA 2000 drop cable to the GPS 19x.
7. Route the NMEA 2000 drop cable away from sources of electronic interference, and connect it to your NMEA 2000 network ([page 8](#)).

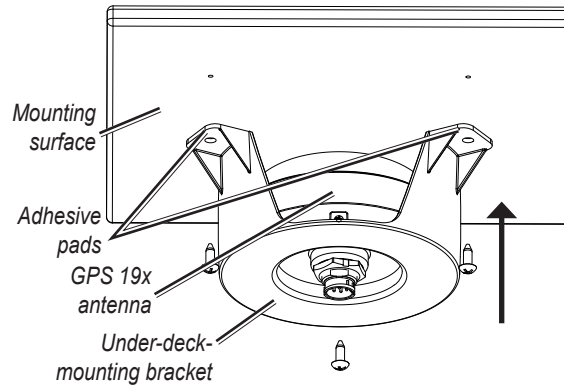

## Installing Cables

The GPSMAP 6000/7000 series chartplotter is packaged with the following cables:

- A two-pin power cable
- A 19-pin NMEA 0183 data cable
- A 17-pin marine video cable (the GPSMAP 7015/7215 chartplotter is packaged with two different marine video cables)
- NMEA 2000 cables and connectors

## Installing Locking Rings on the Cables

To help make the cable-routing process easier, the locking rings are packaged separately from the cables. Each locking ring is packaged in a small bag with a number on the label for easy identification. After you route the cables, use the following table to identify the correct locking ring for each cable:

Cable	Connector Color	Locking Ring Number	Replacement Locking Ring Part Number
Power	Red	①	010-11170-01
NMEA 0183	Blue	②	010-11170-02
Video	Yellow	③	010-11170-00
Video 2 (7015/7215 only)	Purple	③	010-11170-00

### NOTES:

- The NMEA 2000 cables and connectors come with the locking rings pre-installed. Do not remove the locking ring from a NMEA 2000 cable while routing the cable.
- Optional Garmin Marine Network components use specialized Garmin Network cables (not included). Each network cable is also packaged with a separate locking ring, in a bag labeled with a ④. A network-cable specific locking ring should not be used with a GPSMAP 6000/7000 cable.

### Installing a locking ring on a cable:

1. Route the cable away from sources of electronic interference so that the cable connector is at the mounting location of the chartplotter.
2. Use the table above to identify the correct locking ring for the cable, and locate the locking ring bag by number.
3. Separate the two halves of the locking ring.
4. Align the two halves of the locking ring over the cable and snap them together.
5. Insert the O-ring into the end of the connector.

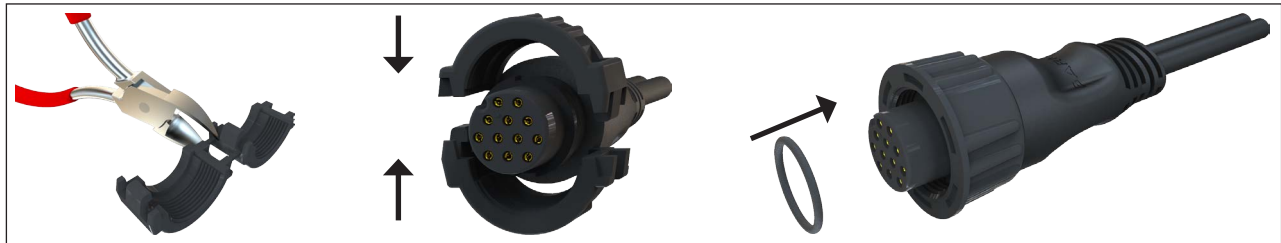

Installing a Locking Ring

### Installing Cable Grommets

Depending on the installation, it may be necessary to drill holes to route the connector end of the GPSMAP cables. Rubber grommets are provided to cover the cable holes for a finished look. You may not need the grommets in some installations. The grommets do NOT create a waterproof seal. To create a waterproof seal, apply a marine sealant around the grommet and cable after installation. Be sure to test the system before installing and sealing the grommets. Purchase additional grommets from your Garmin dealer or directly from Garmin at [www.garmin.com](http://www.garmin.com).

#### Tools Required

- Drill
- 1 1/4 in. (31.7 mm) paddle drill bit or hole saw
- Utility knife
- Marine sealant (optional)

#### To install the cable grommet:

1. Mark the location where you want to route the cable (power, NMEA 0183, NMEA 2000, Marine Video, or Marine Network.)
2. Using a 1 1/4 in. (31.7 mm) paddle drill bit or hole saw, drill the installation hole.
3. Refer to the diagram on [page 7](#) for trimming instructions. Carefully trim the cable hole in the grommet, as needed.
4. Route the cable to the chartplotter, and test the system.
5. Spread the grommet apart at the split and place it around the cable.
6. Firmly push the grommet into the installation hole until it is seated.
7. Apply marine sealant, as needed, to weatherproof the installation-hole (optional).

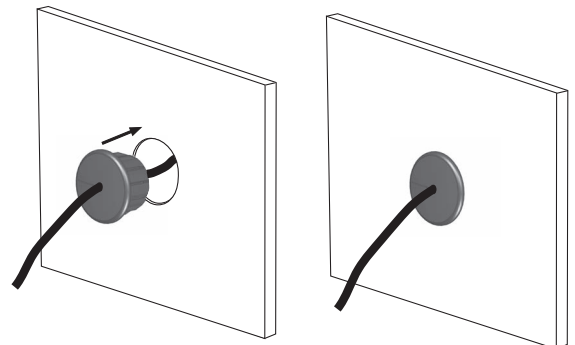
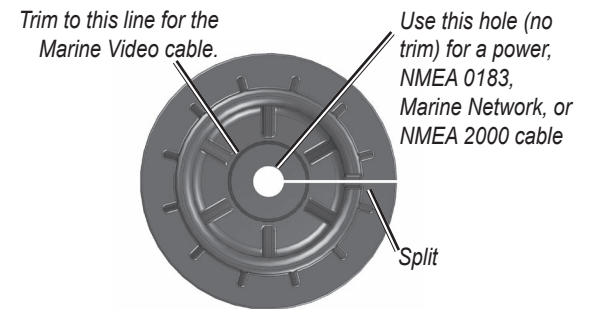

### Wiring the Power Cable

The GPSMAP 6000/7000 series chartplotter must be connected to the power supply for the boat.

1. Route the included 2-pin power cable to the boat battery and to the chartplotter.
2. Connect the power (red) and ground (black) wires to the battery terminals.

#### NOTES:

- Use 14 AWG shielded wiring for extended runs of wire to the power cable.
- Solder all connections and seal them with heat-shrink tubing.

# Installing the GPSMAP 6000/7000 Series Chartplotter and the GPS 19x Antenna NMEA 2000 Network Connections

The GPSMAP 6000/7000 series chartplotter is packaged with the necessary NMEA 2000 connectors and cable to either connect a GPSMAP 6000/7000 series chartplotter and a GPS 19x antenna to your existing NMEA 2000 network, or to build a basic NMEA 2000 network. For more information on NMEA 2000, visit [www.garmin.com](http://www.garmin.com).

If you are unfamiliar with NMEA 2000, be sure to read the “NMEA 2000 Network Fundamentals” chapter of the *Technical Reference for Garmin NMEA 2000 Products* on the included CD or click on the “Manuals” hyperlink on the product page for your chartplotter at [www.garmin.com](http://www.garmin.com). For example, [www.garmin.com/products/GPSMAP7212/](http://www.garmin.com/products/GPSMAP7212/).

## Connecting to an Existing NMEA 2000 Network

If your boat already has a NMEA 2000 network installed, use the included T-connectors and drop cable to connect a GPSMAP 6000/7000 series chartplotter and a GPS 19x antenna to the existing network.

### NOTICE

If you have an existing NMEA 2000 network on your boat, it should already be connected to power. Do not connect the included NMEA 2000 power cable to an existing NMEA 2000 network.

### To connect a GPSMAP 6000/7000 series chartplotter and a GPS 19x to your existing NMEA 2000 network:

1. Identify where you want to connect the GPSMAP 6000/7000 series chartplotter and the GPS 19x to your existing NMEA 2000 backbone.

2. Disconnect one side of a NMEA 2000 T-connector from the backbone nearest to the location where you want to connect the chartplotter.

To extend the NMEA 2000 backbone (if necessary), connect an appropriate NMEA 2000 backbone extension cable (not included) to the side of the T-connector you disconnected.

3. Connect an included T-connector to the NMEA 2000 backbone (for the chartplotter).

4. Route an included drop cable to the chartplotter and to the top of the T-connector you added to your NMEA 2000 network.

If the included drop cable is not long enough, you can add a drop cable extension up to 13 ft. (4 m). If more cable is needed, add an extension to your NMEA 2000 backbone, based on the NMEA 2000 guidelines.

5. Disconnect one side of a NMEA 2000 T-connector from the backbone nearest to the location where you want to connect the GPS 19x antenna.

To extend the NMEA 2000 backbone (if needed), connect an appropriate NMEA 2000 backbone extension cable (not included) to the side of the T-connector you disconnected.

6. Connect an included T-connector in the NMEA 2000 backbone (for the GPS 19x antenna).

7. Route an included drop cable from the GPS 19x antenna to the top of the T-connector you added to your NMEA 2000 network.

If the included drop cable is not long enough, you can add a drop cable extension up to 13 ft. (4 m). If more cable is needed, add an extension to your NMEA 2000 backbone, based on the NMEA 2000 guidelines.

### NOTES:

- The diagram on [page 8](#) shows only the NMEA 2000 data connection to a GPSMAP 6000/7000 series chartplotter. The chartplotter must also be connected to power or it will not function.
- One GPS antenna will provide position data for every device on the NMEA 2000 network. Do not connect multiple GPS antennas if you are using multiple chartplotters.

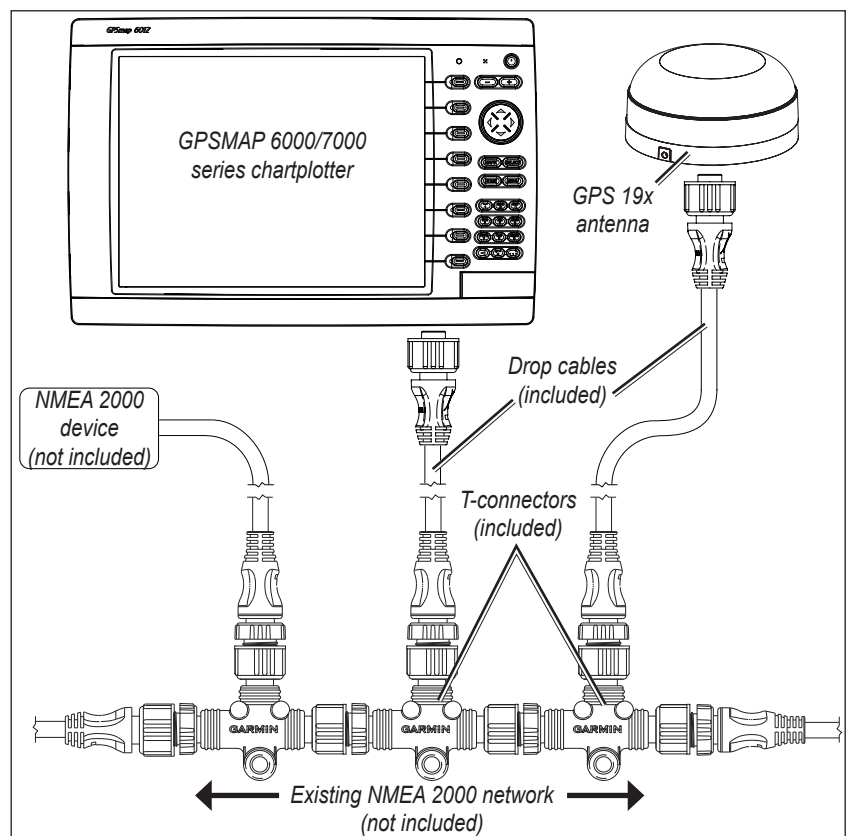

**Connecting a GPSMAP 6000/7000 Series Chartplotter and a GPS 19x Antenna to an Existing NMEA 2000 Network**



## Creating a Basic NMEA 2000 Network

If your boat does not already have an existing NMEA 2000 network installed, you must create a basic NMEA 2000 network.

### To create a basic NMEA 2000 network:

1. Connect the three included T-connectors together, side by side.
2. Connect the terminators to the ends of the combined T-connectors.
3. Wire the included NMEA 2000 power cable to a 12 Vdc power source through a switch. Connect the power cable to the ignition switch of the boat if possible.
4. Connect the NMEA 2000 power cable to the top of one of the T-connectors.
5. Route and connect the included NMEA 2000 drop cables from the GPS 19x and from the GPSMAP 6000/7000 series chartplotter to the tops of the other T-connectors.

### NOTES:

- The diagram shows only the NMEA 2000 data connection to the GPSMAP 6000/7000 series chartplotter. The chartplotter must also be connected to power or it will not function ([page 7](#)).
- One GPS antenna will provide position data for every device on the NMEA 2000 network. Do not connect multiple GPS antennas if you are using multiple chartplotters.

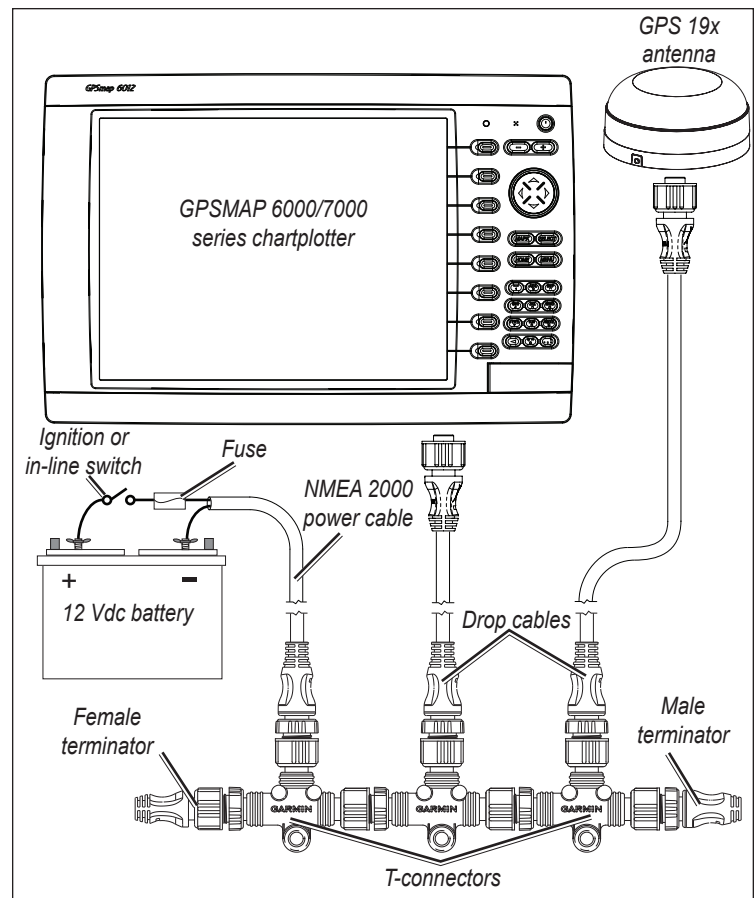

Creating a Basic NMEA 2000 Network

## Wiring a Garmin Marine Network

The optional Garmin Marine Network is a plug-and-play system that allows for high-speed data transfer between multiple Garmin chartplotters and other network-compatible Garmin devices such as a Garmin sonar unit (GSD 22), or a Garmin radar (GMR™ 18 HD or GMR 1206 xHD). The GPSMAP 6000/7000 series chartplotters have three network ports that can be used to connect other Garmin network-compatible chartplotters and devices. If the network requires more ports, use a Garmin Marine Network port extender (GMS 10), or another GPSMAP 6000/7000. Data from each connected component is shared by all the connected Garmin chartplotters.

### NOTES:

- NMEA 0183 devices must all be wired to one chartplotter on the network. The data is then shared over the network to other connected chartplotters.
- Connect all chartplotters to the NMEA 2000 network as well as to the Garmin Marine Network. NMEA 2000 data is not shared over the Garmin Marine Network.
- Connect network components, such as a Garmin GMR radar or GSD sounder to any chartplotter on the network or to an optional GMS 10 Network Port Expander. Data is shared between all chartplotters on the network.
- BlueChart® g2 Vision® cartography data is shared between any connected GPSMAP 6000/7000 series and GPSMAP 4000/5000 series chartplotter.
- Video inputs from the Marine Video cables are only viewable on the connected chartplotter.
- You can connect a GPSMAP 6000/7000 chartplotter to a Marine Network with a GPSMAP 3000 series chartplotter:
  - They will share GPS position information as well as information to and from standard NMEA 0183 devices.
  - They will share information from connected network compatible Garmin devices such as a sonar unit (GSD 22) or a radar (GMR 18 HD or GMR 1206 xHD).
  - Garmin GPSMAP 3000 series chartplotters cannot share cartography data with the GPSMAP 6000/7000 series chartplotters.
- All network components must be connected to the power source of the boat according to their installation instructions. The following diagrams show only the network connections, not power connections..

## The Garmin Marine Network Cable:

- The Garmin Marine Network Cable (not included) has a locking ring that secures the cable to the chartplotter or marine network device. Because of the size of this locking ring, it is not connected to the network cable at the factory to make it easier to install on your boat.
- After the cable is run to the chartplotter or network device, snap the locking ring together around the connector and insert the rubber washer as indicated on the instructions packaged with the cable.

**NOTE:** The locking ring packaged with a Garmin Marine Network Cable should not be used with any cable packaged with the GPSMAP 6000/7000 series chartplotter.



## Sample Garmin Marine Network Setups:

The following illustrations show common Garmin Marine Network setups. The illustrations only show how the devices connect to each other using Garmin Marine Network cables. No power connections are shown in any of the diagrams. Ensure that you wire each device to power according to the appropriate installation instructions.

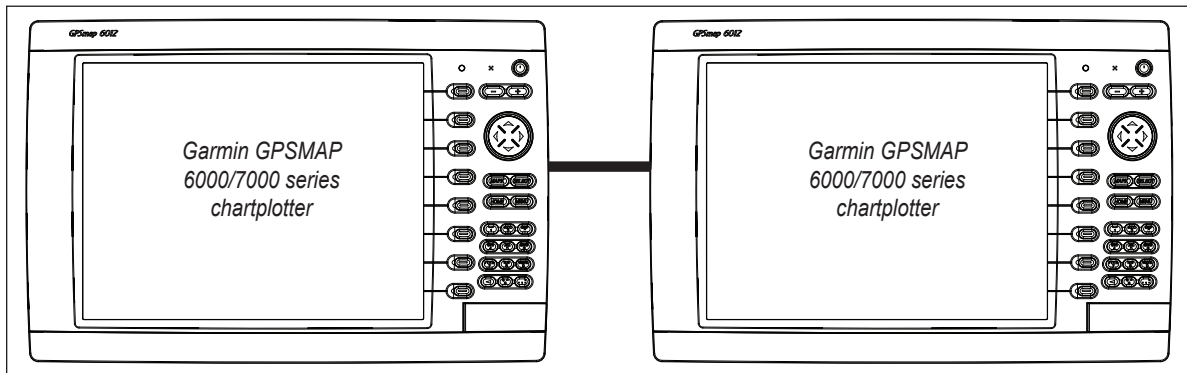

**Marine Network with Two Chartplotters**

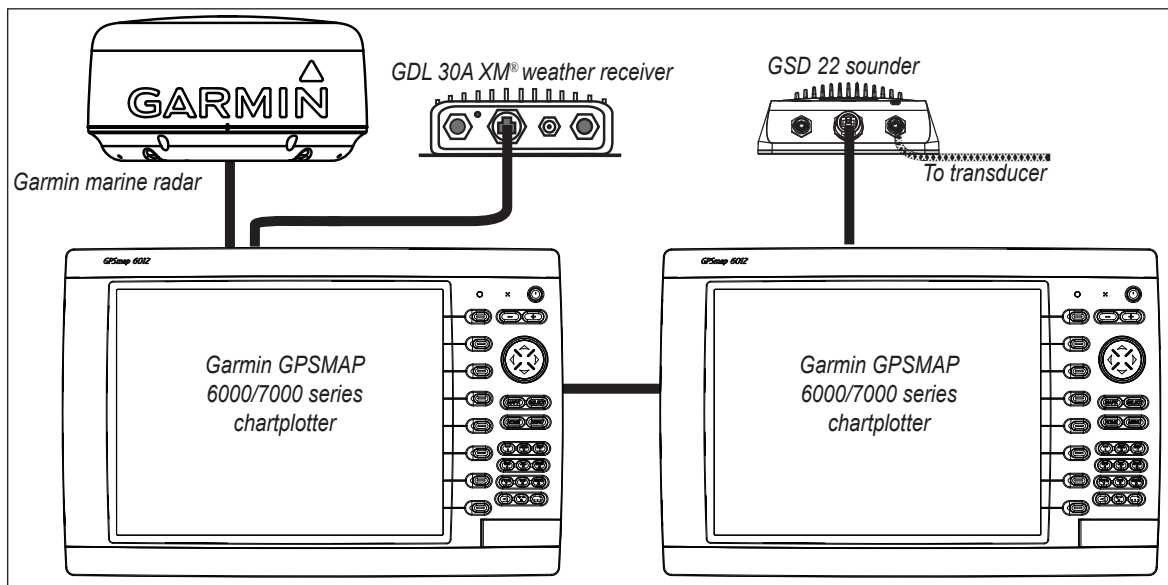

**Extended Marine Network with Two Chartplotters**

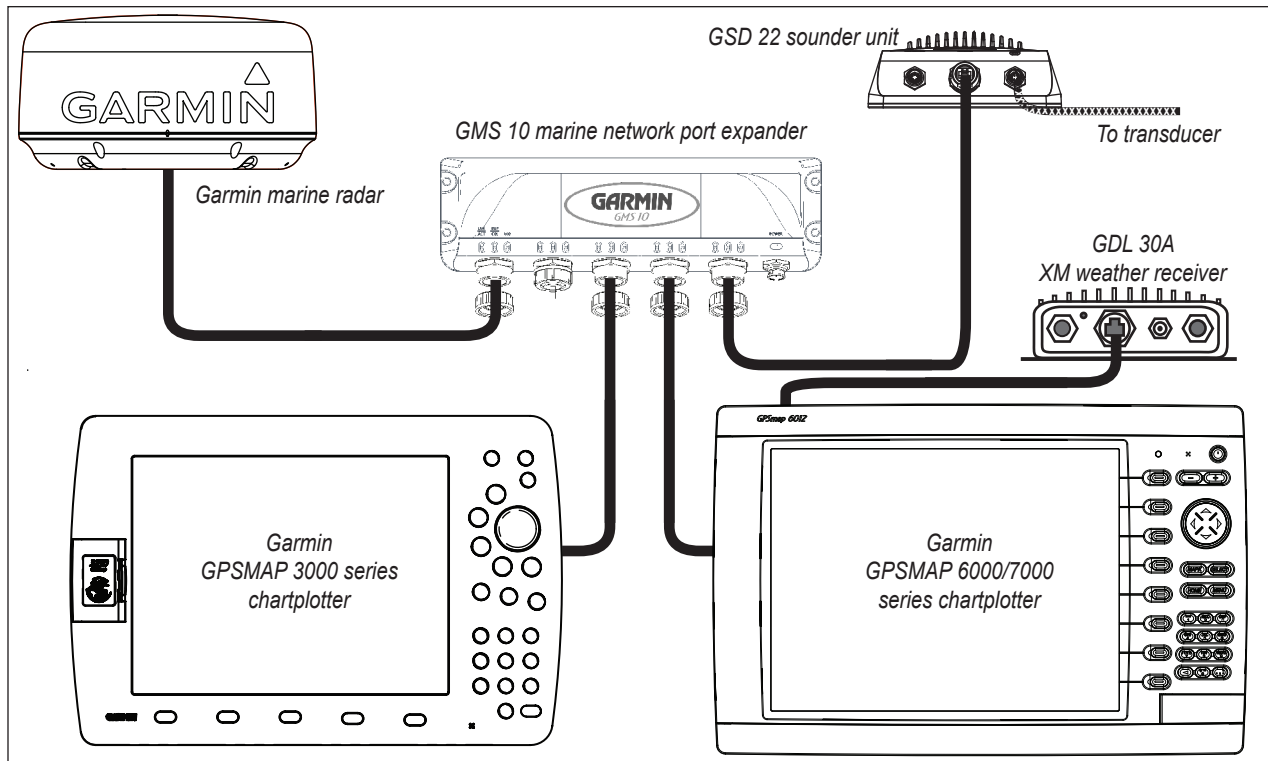

**Connecting a GPSMAP 6000/7000 Series Chartplotter to an Existing Garmin Marine Network**

**NOTES:**

- Every device connected to the Garmin Marine Network must be connected to the power supply for the boat. These diagrams show the network connections; however, they **do not show the power connections**. Wire each device according to the appropriate installation instructions.
- These diagrams show the Garmin Marine Network connections; however, they **do not show NMEA 2000 or NMEA 0183 connections**.
- When connecting a GPSMAP 6000/7000 series chartplotter to an existing Garmin Marine Network, the GMS 10 can be used but is not necessary. The GPSMAP 6000/7000 series chartplotter has three network ports and acts as a port expander. Wire the GPS antenna and additional NMEA devices to either an existing chartplotter or the new GPSMAP 6000/7000 Series chartplotter. The existing chartplotter and the new GPSMAP 6000/7000 series chartplotter share NMEA 0183 data and Garmin Marine Network data.

## Wiring Additional NMEA 0183 Devices

The NMEA 0183 data cable included with the GPSMAP 6000/7000 series chartplotter supports the NMEA 0183 standard, which is used to wire various NMEA 0183-compliant devices, such as VHF radios, NMEA instruments, autopilots, or a computer.

### Basic NMEA 0183 Wiring

These diagrams illustrate basic NMEA 0183 wiring used to connect your GPSMAP 6000/7000 series chartplotter to NMEA 0183-compliant devices such as an AIS or DSC device. For more-complete information on the NMEA 0183 capabilities of the GPSMAP 6000/7000 series chartplotter, see the “Advanced NMEA 0183 Wiring” section ([page 13](#)).

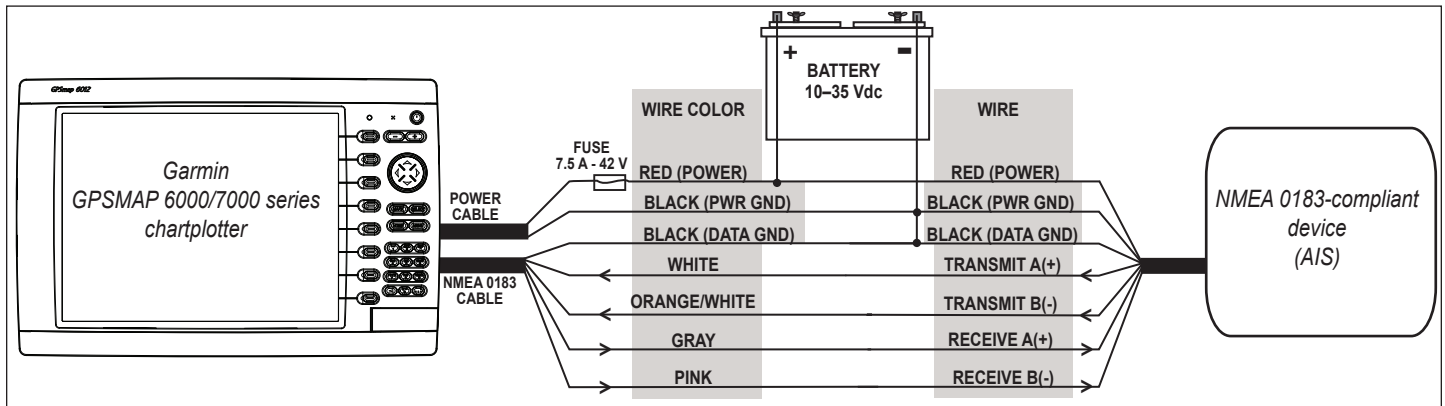

Wiring to a NMEA 0183-compliant Device (AIS)

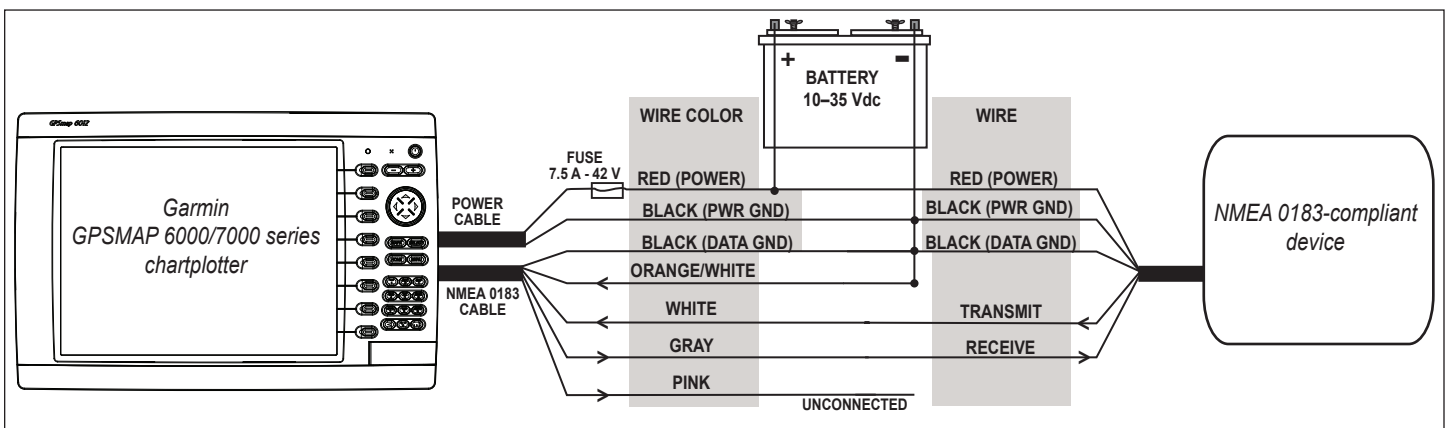

Wiring to a Single-ended NMEA 0183-compliant Device

#### Notes:

- If the NMEA 0183-compliant device has only one receiving wire (no A, B, +, or -), leave the **pink** wire unconnected.
- If the NMEA 0183-compliant device has only one transmitting wire (no A, B, +, or -), connect the **orange/white** wire to ground.
- Consult the installation instructions of your NMEA 0183-compliant device to identify the Transmit A(+) and B(-) wires and Receive A(+) and B(-) wires.
- Use 28 AWG, shielded, twisted-pair wiring for extended runs of wire.
- Solder all connections and seal them with heat-shrink tubing.

## Advanced NMEA 0183 Wiring

The GPSMAP 6000/7000 series chartplotter has four ports to receive NMEA 0183 data (RX ports), and two ports to send NMEA 0183 data (TX ports). Wire one NMEA 0183 device per RX port to send data to a 6000/7000 series chartplotter, wire up to three NMEA 0183 devices in parallel to each TX port to receive data from a 6000/7000 series chartplotter.

Each RX and TX port has 2 wires, labeled A (+) and B (-) according to the NMEA 0183 convention. Connect the corresponding A (+) and B (-) wires of each port to the A (+) and B (-) wires of your NMEA 0183-compliant device. Refer to the table and wiring diagrams when wiring the 6000/7000 chartplotter to NMEA 0183 devices.

**Consult the installation instructions for your NMEA 0183-compliant device to identify the Transfer (TX) A (+) and B (-) wires and Receiving (RX) A (+) and B (-) wires.** Use 28 AWG, shielded, twisted-pair wiring for extended runs of wire. Solder all connections and seal them with heat-shrink tubing.

### Notes:

- For two-way communication with a NMEA 0183 device, the ports on the GPSMAP 6000/7000 chartplotters are not linked. For example, if the RX port of the NMEA-compliant device is wired to TX port 1 on the GPSMAP 6000/7000, you can wire the TX port of your NMEA 0183-compliant device to RX port 1, port 2, port 3, or port 4 on the GPSMAP 6000/7000.
- The ground wires on the NMEA 0183 data cable from the GPSMAP 6000/7000 series chartplotter and your NMEA 0183-compliant device must both be grounded.
- Approved NMEA 0183 sentences—GPAPB, GPBOD, GPBWC, GPGGA, GPGLL, GPGSA, GPGSV, GPRMB, GPRMC, GPRTE, GPVTG, GPWPL, GPXTE, and Garmin proprietary sentences—PGRME, PGRMM, and PGRMZ.
- The GPSMAP 6000/7000 series chartplotter also includes support for the WPL sentence, DSC, and sonar NMEA 0183 input with support for the DPT (depth) or DBT, MTW (water temperature), and VHW (water temperature, speed, and heading) sentences.
- Select **Configure > Communications** on the GPSMAP 6000/7000 series chartplotter to set up NMEA 0183 communications. See the *GPSMAP 6000/7000 Series Owner's Manual* for details.

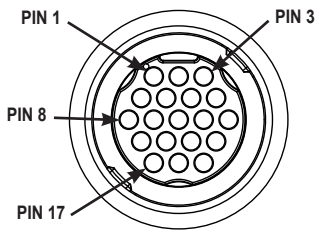
Port	Wire Function	Wire Color	Pin Number	Connector
Receiving Port 1	RX / A (+)	White	1	 <p>NMEA 0183 Cable End View</p>
	RX / B (-)	Orange/White	2	
Receiving Port 2	RX / A (+)	Brown	5	
	RX / B (-)	Brown/White	6	
Receiving Port 3	RX / A (+)	Violet	9	
	RX / B (-)	Violet/White	10	
Receiving Port 4	RX / A (+)	Black/White	11	
	RX / B (-)	Red/White	12	
Transmitting Port 1	TX / A (+)	Gray	3	
	TX / B (-)	Pink	4	
Transmitting Port 2	TX / A (+)	Blue	7	
	TX / B (-)	Blue/White	8	
N/A	GPS 17 IN	Green/White	13	
N/A	GPS 17 OUT	Green	14	
N/A	SPARE		15	
N/A	ALARM	Yellow	16	
N/A	ACCESSORY ON	Orange	17	
N/A	GROUND	Black	18	
N/A	SPARE		19	

GPSMAP 6000/7000 Series NMEA 0183 Data Cable

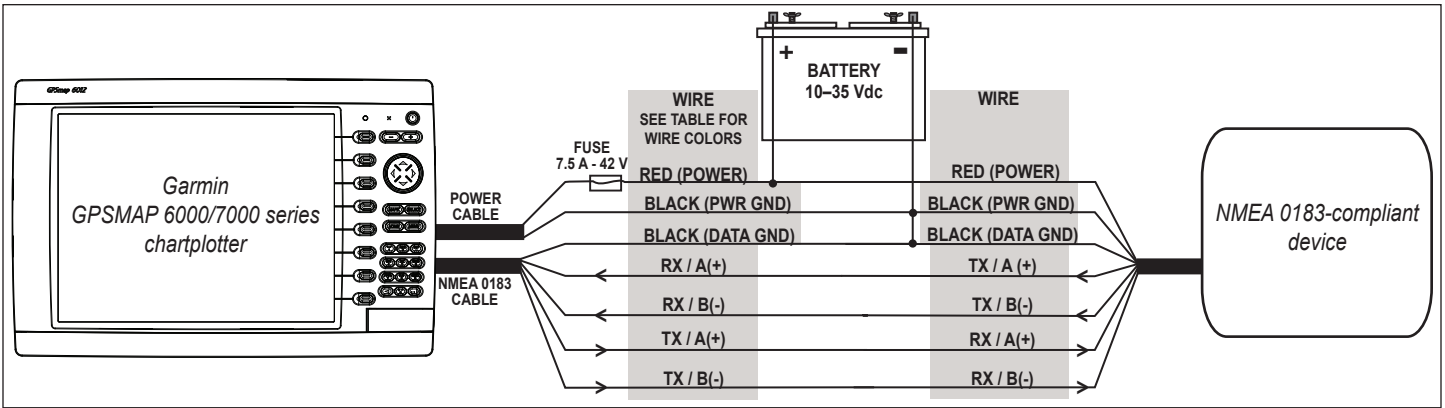

**Wiring to a Standard NMEA 0183-compliant Device with 2-way Communication**

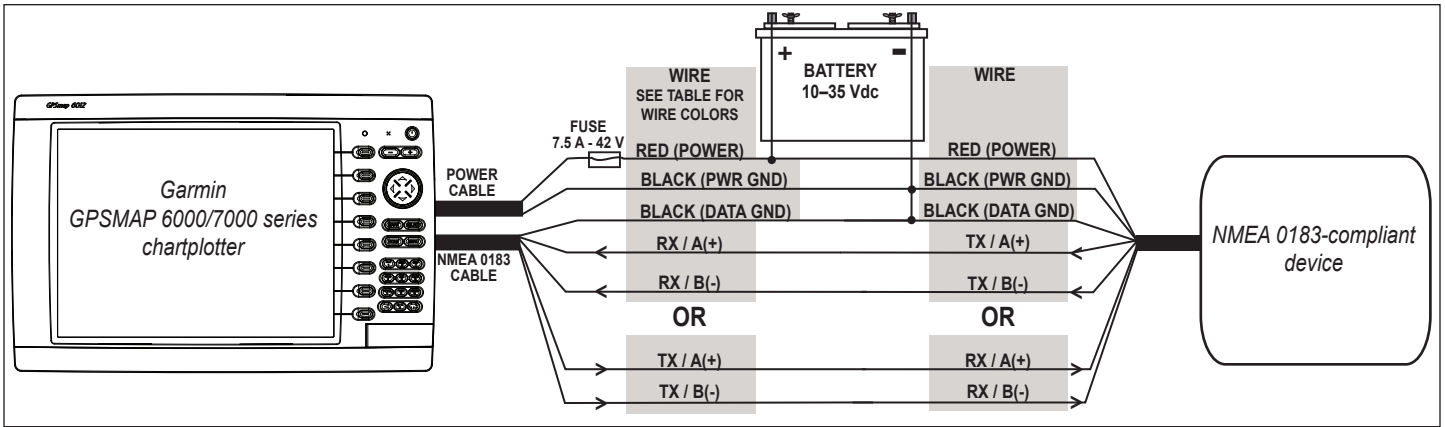

**Wiring to a Standard NMEA 0183-compliant Device for One-Way Communication**

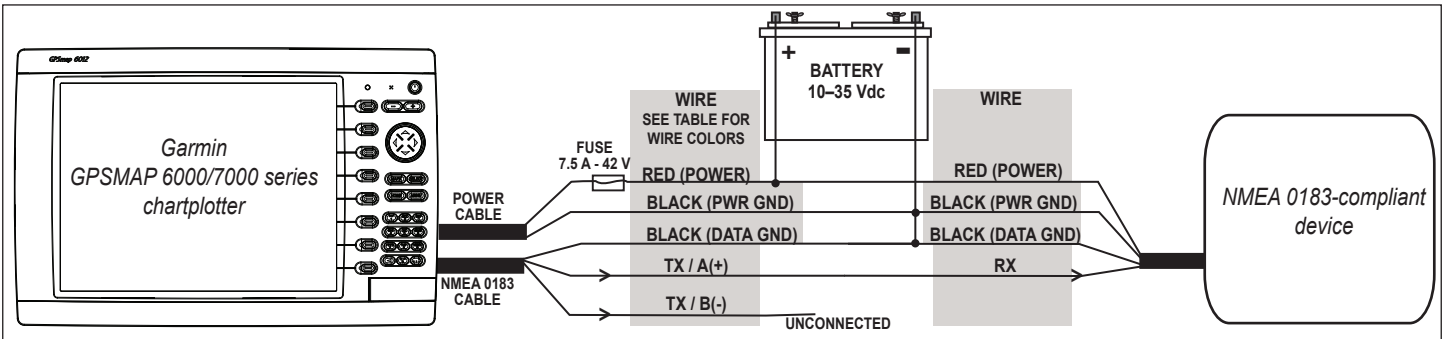

**Wiring to Send Data to a NMEA 0183-compliant Device With a Single Wire TX Connection**

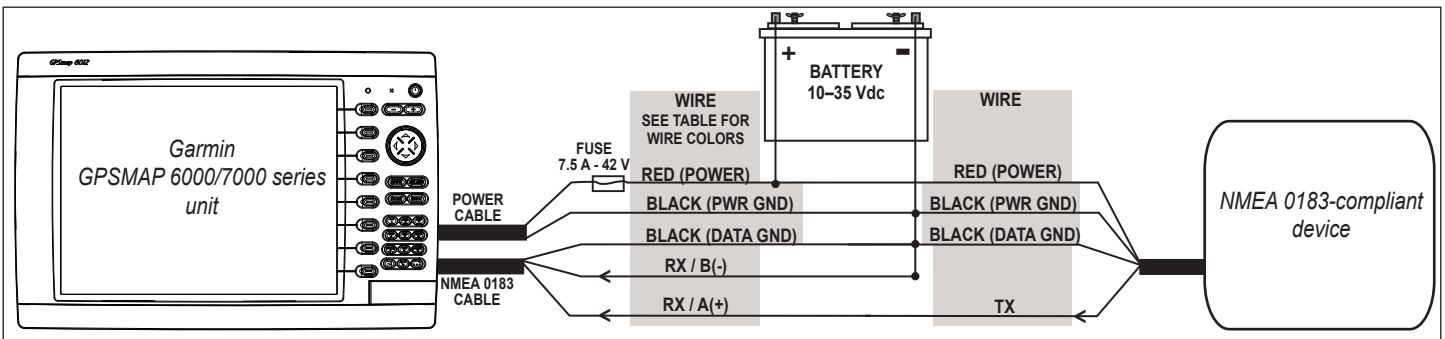

**Wiring to Receive Data from a NMEA 0183-compliant Device With a Single Wire RX Connection**

## Wiring to a Lamp or to a Horn (Optional)

The GPSMAP 6000/7000 series chartplotter can be used with a lamp, a horn, or both, to sound or flash an alert when the chartplotter displays a message. The alarm does not need to be wired for the GPSMAP 6000/7000 chartplotter to function. The alarm circuit switches to a low-voltage state when the alarm sounds. The maximum current is 100 mA, and a relay is needed to limit the current from the chartplotter to 100 mA. To manually toggle visual and audible alerts, install single-pole, single-throw switches.

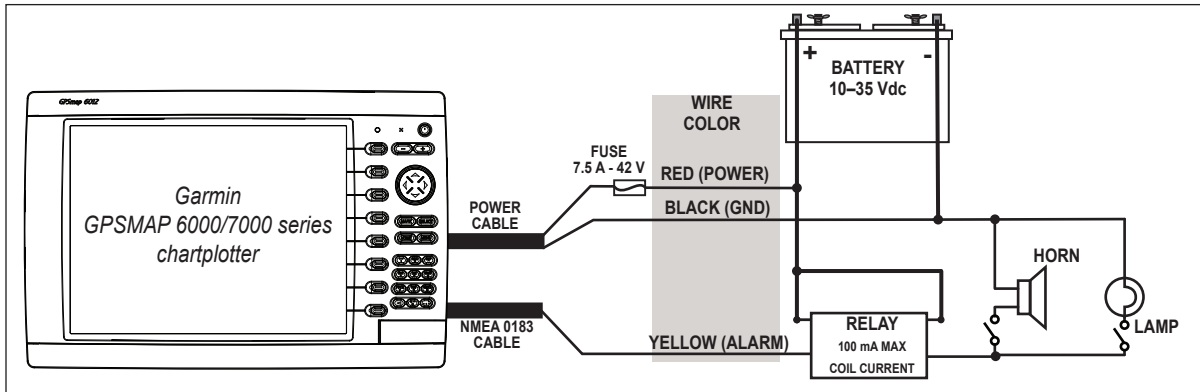

Wiring to a Lamp, a Horn, or Both

## Wiring to a DB-9 PC Serial Connector

The GPSMAP 6000/7000 series chartplotters can be connected to a PC with a serial port by wiring the chartplotter to a DB-9 serial connector.

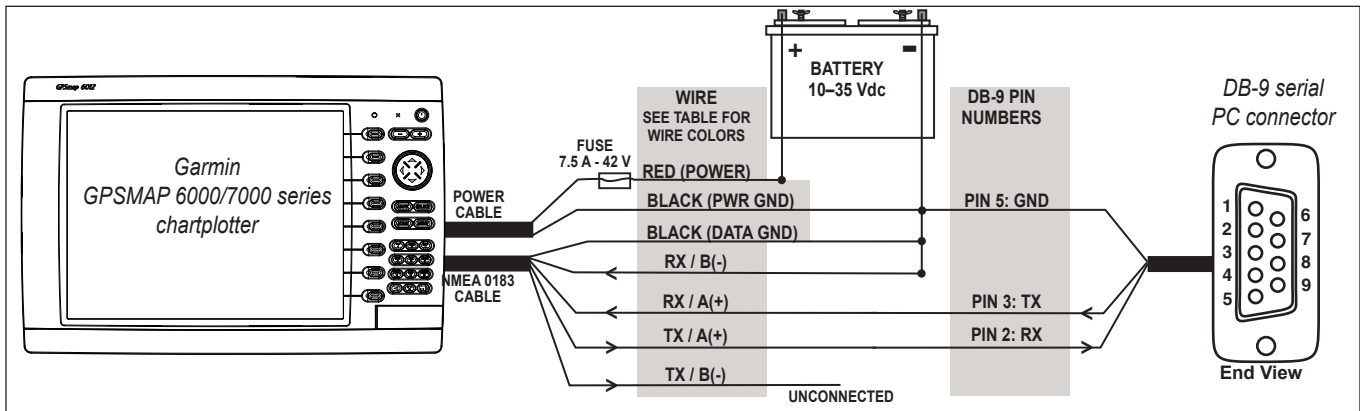

Wiring to a DB-9 Serial PC Connector

## Wiring to a GPS 17 or GPS 17 HVS Antenna

If you already have a Garmin GPS 17 or GPS 17 HVS installed on your boat, you can wire it to the GPSMAP 6000/7000 series chartplotter instead of installing the included GPS 19x. Wire the existing GPS 17 or GPS 17 HVS antenna to the included 19-pin NMEA 0183 cable as well as to the power supply for the boat, referring to the diagram below. Use 22 AWG shielded wiring for extended runs of wire to the NMEA 0183 cable or GPS 17 HVS cable. Solder all connections and seal them with heat-shrink tubing.

**NOTE:** If you are using more than one Garmin chartplotter over a Garmin Marine Network, do not wire more than one chartplotter to a GPS antenna. The GPS signal is shared between multiple chartplotters connected to a Garmin Marine Network.

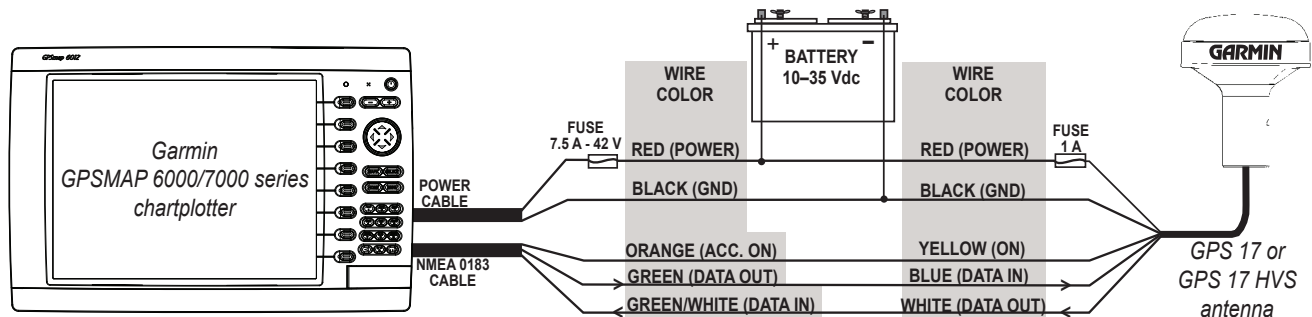

Wiring to a GPS 17 or GPS 17 HVS Antenna

## Installing Video Cables

The GPSMAP 6000/7000 series chartplotters allow video input and monitor output using the included marine video 17-pin cable. The GPSMAP 7015/7215 chartplotters have a second marine video 17-pin cable to allow for additional video sources. The GPSMAP 6000/7000 series chartplotters allow for National Television System Committee (NTSC) and Phase Alternate Line (PAL) composite video sources, and PC monitor output (6008/6208 = VGA output, 6012/6212/7012/7212/7015/7215 = XGA output). The marine video cable inputs are only available on the chartplotter to which they are attached and will not transmit over the Garmin Marine Network. For detailed marine video pinout information, see the appendix (page 19).

### Primary Video Cable (Video—Yellow Connector)

This cable is supplied with all GPSMAP 6000/7000 series chartplotters, and connects to the yellow video connector on the back of the chartplotter. This cable allows for two separate composite video sources and it allows for video output to an external PC monitor.

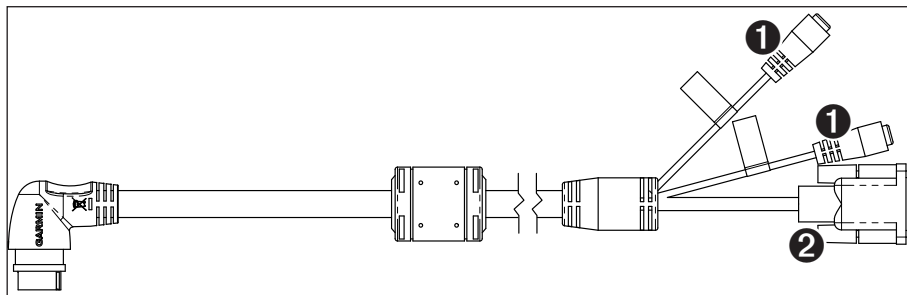

Primary Video Cable

- 1 Video 1 and Video 2 inputs (RCA connectors) allow input from two separate NTSC/PAL compatible composite video devices, such as a VCR, a DVD player, a TV, or a video camera. The chartplotter can display one video input at a time or alternate between the two. See the *GPSMAP 6000/7000 Series Owner's Manual* for details. Sound from a video source must be attached to a separate stereo/audio system.
- 2 Use the PC monitor output (HD 15-pin) connector for remote viewing of the chartplotter display on a computer monitor. The remote monitor must be capable of at least VGA resolution and have multi-sync capability. Ensure that the ground of the connected monitor is connected to the same ground as the GPSMAP 6000/7000 series chartplotter to avoid interference.

### Secondary Video Cable (Video 2—Purple Connector)

This cable is supplied with the GPSMAP 7015/7215 chartplotters, and it is not compatible with any other GPSMAP 6000/7000 series chartplotter. This cable connects to the purple connector on the back of the GPSMAP 7015/7215 chartplotter, and it allows two additional composite video sources, an S-Video source, and PC VGA input.

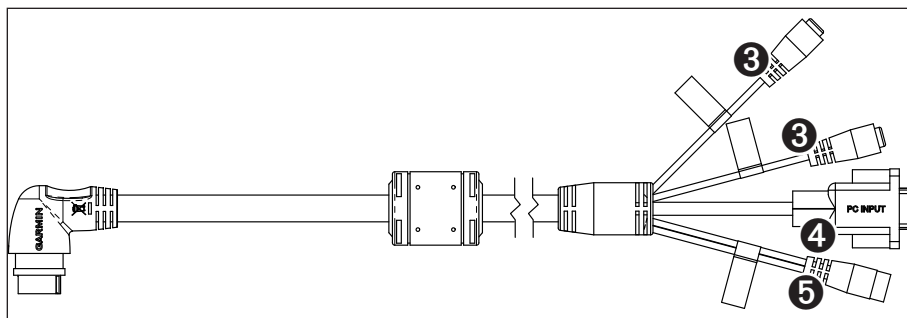

Secondary Video Cable (GPSMAP 7015/7215 Only)

- 3 Video 3 and Video 4 inputs (RCA connectors) allow two NTSC/PAL compatible composite video devices, such as a VCR, a DVD player, a TV, or a video camera. The GPSMAP 7015/7215 chartplotter can display up to four video inputs at a time, or it can cycle through all connected video inputs. See the *GPSMAP 6000/7000 Series Owner's Manual* for details. Sound from a video source must be attached to a separate stereo/audio system.
- 4 Connect a computer to the PC monitor input (HD 15-pin) connector to use the GPSMAP 7015/7215 chartplotter as a computer monitor. See the *GPSMAP 6000/7000 Series Owner's Manual* for details.
- 5 S-Video input (S-Video connector) allows input of NTSC/PAL compatible S-Video devices, such as a VCR, a DVD player, a TV, or a video camera. An S-Video connection provides a higher-quality video signal than a composite video connection.



## Making the Final Connections to the GPSMAP 6000/7000 Series Chartplotter

After the power cable and the GPS antenna (as well as any optional Garmin Marine Network devices, NMEA 0183 devices, NMEA 2000 connections, or video connections) are wired to the boat, connect the cables to the GPSMAP 6000/7000 series chartplotter.

Note: You must install the locking rings before connecting the cables to the chartplotter ([page 6](#)).

### To connect a cable to the back of a GPSMAP 6000/7000 series chartplotter:

1. Carefully press the cable into the correct port on the back of the chartplotter until it is firmly seated. **Do not force the cable, because this may damage the pins.**
2. After the cable is seated, turn the locking ring clockwise until it is tight. Be careful not to overtighten the locking ring.

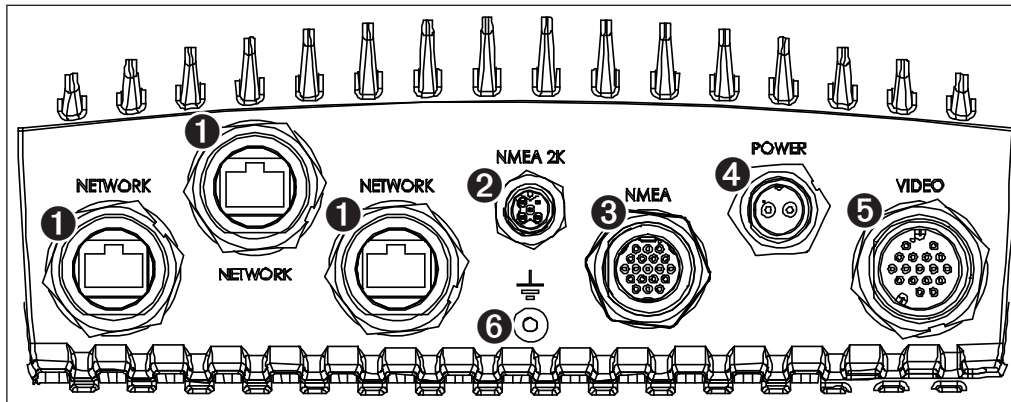

GPSMAP 6008/6208/6012/6212/7012/7212 Connectors

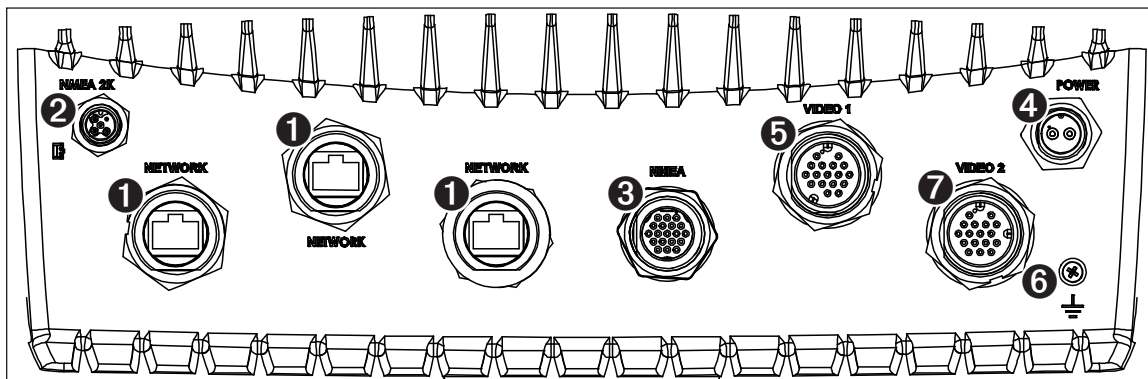

GPSMAP 7015/7215 Connectors

- |   |  |
|---|--|
| ❶ Garmin Marine Network connectors (×3) (Black) | ❺ Video connector (Yellow)                           |
| ❷ NMEA 2000 connector (Black)                   | ❻ Grounding lug (unused in a typical installation)   |
| ❸ NMEA 0183 connector (Blue)                    | ❼ Video 2 connector (GPSMAP 7015/7215 only) (Purple) |
| ❹ Power connector (Red)                         |  |

## Updating the Chartplotter Software

The GPSMAP 6000/7000 series chartplotter may contain a software update SD card. If so, follow the instructions provided with the card.

If a software update SD card is not included, visit [www.garmin.com](http://www.garmin.com) to make sure your chartplotter software is up-to-date. To identify the version of software on your chartplotter, select or touch **Configure > System > System Information**.

# Appendix

## Specifications

### Physical Specifications

Specification	Devices	Measurement
Size	GPSMAP 6008, 6208	W × H × D: 11 1/2 × 7 3/8 × 5 7/8 in. (291.5 × 187.8 × 148.5 mm)
	GPSMAP 6012, 6212	W × H × D: 15 1/32 × 9 57/64 × 5 27/32 in. (381.7 × 251.2 × 148.7 mm)
	GPSMAP 7012, 7212	W × H × D: 13 9/32 × 9 7/8 × 5 27/32 in. (336.8 × 251.5 × 147.8 mm)
	GPSMAP 7015, 7215	W × H × D: 15 17/32 × 11 27/32 × 5 7/8 in. (394.9 × 300.7 × 148.5 mm)
Weight	GPSMAP 6008, 6208	11 lb., 5 oz. (5.12 kg)
	GPSMAP 6012, 6212	15 lb., 15 oz. (7.23 kg)
	GPSMAP 7012, 7212	15 lb., 5 oz. (6.94 kg)
	GPSMAP 7015, 7215	17 lb., 6 oz. (7.87 kg)
Display	GPSMAP 6008, 6208	W × H: 6 3/4 × 5 1/8 in. (174 × 131.3 mm)
	GPSMAP 6012, 6212, 7012, 7212	W × H: 9 11/16 × 7 1/4 in. (245.8 × 184.3 mm)
	GPSMAP 7015, 7215	W × H: 12 × 9 in. (304.1 × 228.1 mm)
Case	All models	Fully gasketed, high-impact plastic and aluminum alloy, waterproof to IEC 60529 IPX-7
Temp. Range	All models	From 5°F to 131°F (from -15°C to 55°C)
Compass Safe Distance	GPSMAP 6008, 6208	15 in. (38.1 cm)
	GPSMAP 6012, 6212	16 in. (40.6 cm)
	GPSMAP 7012, 7212	25 in. (63.5 cm)
	GPSMAP 7015, 7215	17 in. (43.2 cm)
 - Lamps inside this product contain mercury and must be recycled or disposed of according to local, state, or federal laws. For information, go to: <a href="http://www.garmin.com/aboutGarmin/environment/disposal.jsp">www.garmin.com/aboutGarmin/environment/disposal.jsp</a> .		

### GPS Performance

Specification	Parameter	Measurement
Receiver		GPS19x: High Sensitivity Differential-ready 12 parallel channel WAAS-capable receiver
Acquisition Time	Warm	Approximately 38 sec. (The device is at or near the last location at which you recently acquired satellites)
	Cold	Approximately 45 sec. (The device has moved more than about 500 mi. (800 km) since it was turned off.)
	Reacquisition	< 2 seconds
Update Rate		1/sec., continuous
Accuracy	GPS	<33 ft. (10 m) 95% typical
	DGPS	10-16 ft. (3-5 m) 95% typical (WAAS/EGNOS accuracy)
Velocity		0.05 m/sec. steady state

### Power

Specification	Devices	Measurement
Source	All models	10-35 Vdc
Usage	GPSMAP 6008, 6208	35 W max. at 10 Vdc
	GPSMAP 6012, 6212, 7012, 7212	45 W max. at 10 Vdc
	GPSMAP 7015, 7215	65 W max. at 10 Vdc
Fuse	All models	7.5 A, 42 V fast-acting
NMEA 2000 Load Equivalency Number (LEN)	All models	2
NMEA 2000 Draw	All models	75 mA maximum

### NMEA 2000 PGN Information

Receive		Transmit	
059392	ISO Acknowledgment	059392	ISO Acknowledgment
059904	ISO Request	059904	ISO Request
060928	ISO Address Claim	060928	ISO Address Claim
126208	NMEA - Command/Request/Acknowledge Group Function	126208	NMEA - Command/Request/Acknowledge Group Function
126464	Transmit/Receive PGN List Group Function	126464	Transmit/Receive PGN List Group Function
126992	System Time	126996	Product Information
126996	Product Information	127250	Vessel Heading

Receive		Transmit	
127250	Vessel Heading	127258	Magnetic Variance
127489	Engine Parameters - Dynamic	128259	Speed - Water Referenced
127488	Engine Parameters - Rapid Update	128267	Water Depth
127493	Transmission Parameters, Dynamic	129025	Position - Rapid Update
127505	Fluid Level	129026	COG & SOG - Rapid Update
128259	Speed - Water Referenced	129029	GNSS Position Data
128267	Water Depth	129283	Cross Track Error
129025	Position - Rapid Update	129284	Navigation Data
129026	COG & SOG - Rapid Update	129285	Navigation Route/Waypoint Info
129029	GNSS Position Data	129540	GNSS Sats in View
129038	AIS Class A Position Report	130306	Wind Data
129039	AIS Class B Position Report	130312	Temperature
129040	AIS Class B Extended position report		
129539	GNSS DOPs		
129540	GNSS Sats in View		
129794	AIS Class A Static and Voyage Related Data		
129808	DSC Call Information		
129809	AIS Class B "CS" Static Data Report, Part A		
129810	AIS Class B "CS" Static Data Report, Part B		
130306	Wind Data		
130310	Environmental Parameters		
130311	Environmental Parameters		
130312	Temperature		
130313	Humidity		
130314	Actual Pressure		



GPSMAP 6000/7000 series chartplotters are NMEA 2000 certified.

## Marine Video Cable Pin Assignments

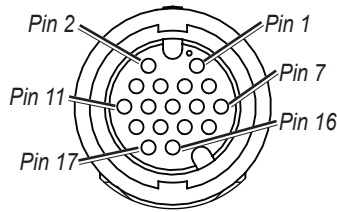

**Primary Marine Video Cable**

Connector	Pin	Function
RCA 1 center	2	Video 1 in
RCA 1 outer	6	Video 1 ground
RCA 2 center	11	Video 2 in
RCA 2 outer	15	Video 2 ground
HD-15 pin 1	1	VGA, analog—red
HD-15 pin 2	4	VGA, analog—green
HD-15 pin 3	3	VGA, analog—blue
HD-15 pin 5	13	VGA, analog—ground
HD-15 pin 6	8	VGA, analog—red, ground
HD-15 pin 7	8	VGA, analog—green, ground
HD-15 pin 8	8	VGA, analog—blue, ground
HD-15 pin 10	13	VGA, sync ground
HD-15 pin 13	7	VGA, horizontal sync
HD-15 pin 14	12	VGA, vertical sync
HD-15 shell	9	VGA, overall shield

**Primary Marine Video Cable Pin Assignments**

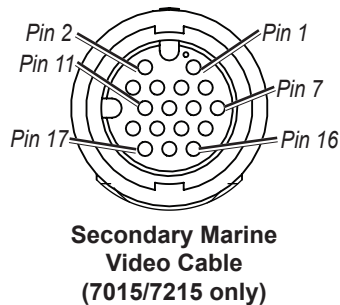

Connector	Pin	Function
RCA 1 center	2	Video 3 in
RCA 1 outer	6	Video 3 ground
RCA 2 center	11	Video 4 in
RCA 2 outer	10	Video 4 ground
HD-15 pin 1	1	VGA, analog—red
HD-15 pin 2	4	VGA, analog—green
HD-15 pin 3	3	VGA, analog—blue
HD-15 pin 5	13	VGA, analog—ground
HD-15 pin 6	8	VGA, analog—red, ground
HD-15 pin 7	8	VGA, analog—green, ground
HD-15 pin 8	8	VGA, analog—blue, ground
HD-15 pin 10	13	VGA, sync ground
HD-15 pin 13	7	VGA, horizontal sync
HD-15 pin 14	12	VGA, vertical sync
HD-15 shell	9	VGA, overall shield
S-Video pin 3	16	S-Video in, luminance
S-Video pin 1	14	S-Video in, luminance, ground
S-Video pin 4	17	S-Video in, chrominance
S-Video pin 2	15	S-Video in, chrominance, ground

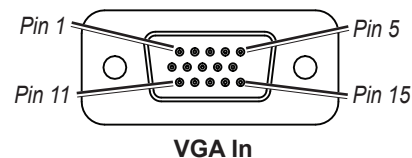
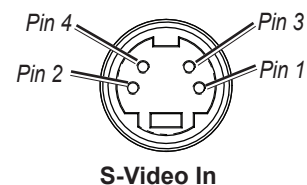

**Secondary Marine Video Cable Pin Assignments (GPSMAP 7015/7215 Only)**

© 2012 Garmin Ltd. or its subsidiaries

All rights reserved. Except as expressly provided herein, no part of this manual may be reproduced, copied, transmitted, disseminated, downloaded or stored in any storage medium, for any purpose without the express prior written consent of Garmin. Garmin hereby grants permission to download a single copy of this manual onto a hard drive or other electronic storage medium to be viewed and to print one copy of this manual or of any revision hereto, provided that such electronic or printed copy of this manual must contain the complete text of this copyright notice and provided further that any unauthorized commercial distribution of this manual or any revision hereto is strictly prohibited.

Information in this document is subject to change without notice. Garmin reserves the right to change or improve its products and to make changes in the content without obligation to notify any person or organization of such changes or improvements. Visit the Garmin Web site ([www.garmin.com](http://www.garmin.com)) for current updates and supplemental information concerning the use and operation of this and other Garmin products.

Garmin®, the Garmin logo, GPSMAP®, BlueChart®, and g2 Vision® are trademarks of Garmin Ltd. or its subsidiaries, registered in the USA and other countries. These trademarks may not be used without the express permission of Garmin. NMEA 2000® is a registered trademark of the National Marine Electronics Association.

XM® and XM WX Satellite Weather® are registered trademarks of XM Satellite Radio Inc.

**For the latest free software updates (excluding map data) throughout the life of your Garmin products, visit the Garmin Web site at [www.garmin.com](http://www.garmin.com).**



© 2012 Garmin Ltd. or its subsidiaries

Garmin International, Inc.  
1200 East 151<sup>st</sup> Street, Olathe, Kansas 66062, USA

Garmin (Europe) Ltd.  
Liberty House, Hounslow Business Park, Southampton, Hampshire, SO40 9LR UK

Garmin Corporation  
No. 68, Zhangshu 2<sup>nd</sup> Road, Xizhi Dist., New Taipei City, 221, Taiwan (R.O.C.)