

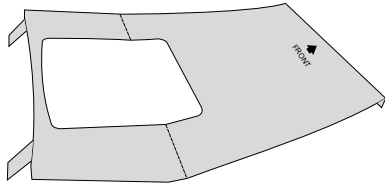

# Navus™ : Dodge Caliber

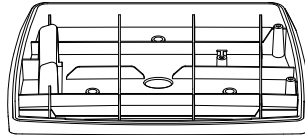

**A**



**B**

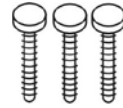

**C**

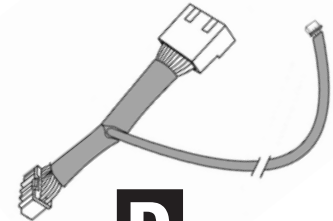

**D**

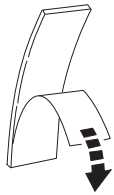

**E**

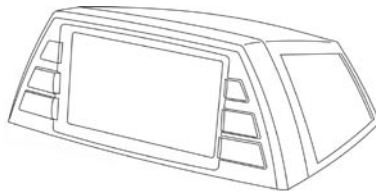

**F**



**G**

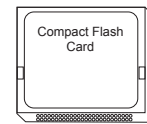

**H**

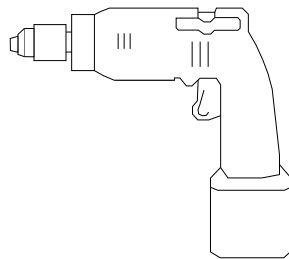
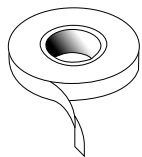

3/16"  
(4.7 mm)



1/2"  
(12.5 mm)

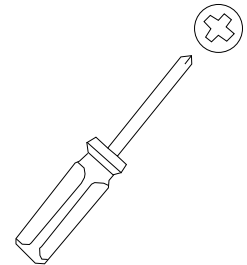

- Disconnect and isolate the negative battery cable.
- Clean dash with isopropyl alcohol.
- Follow the instructions inside to mount the Navus.
- Positioning the template correctly is very important!
- When attaching baseplate to dash, press firmly to activate adhesive.
- Do not exceed a drill depth of 0.8" (20 mm).
- Route cable behind separator in dash to avoid pinching cable.
- Apply mercury warning label to B-pillar, as shown.

- Débranchez et isolez le câble négatif de la batterie.
- Nettoyez le tableau de bord avec de l'alcool isopropylique.
- Suivez les directives incluses pour installer le Navus.
- Il est très important de placer le gabarit correctement!
- Pour fixer le socle sur le tableau de bord, appuyez fermement afin d'activer l'adhésif.
- La profondeur de perçage ne doit pas dépasser 20 mm (0,8 po).
- Acheminez le câble derrière le séparateur afin de ne pas pincer le câble.
- Apposez l'étiquette d'avertissement de mercure sur le montant B, comme illustré.

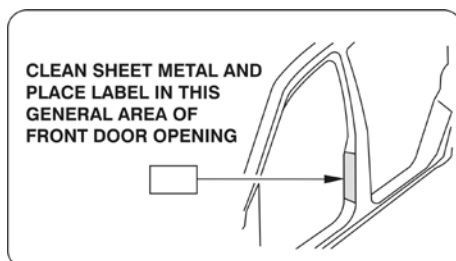

K6859543

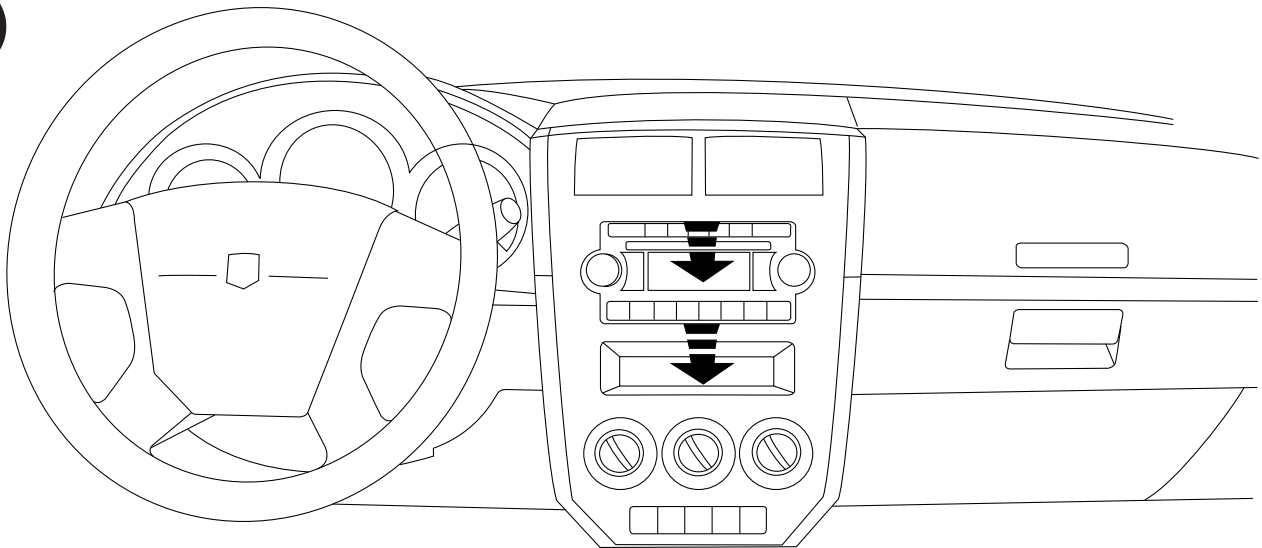
**1**

Remove trim panel and radio. ♦ Retirez le panneau de garniture et la radio.

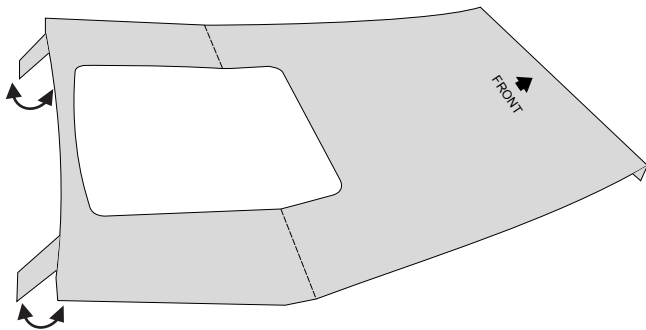
**2****A**

Fold template. ♦ Pliez le gabarit.

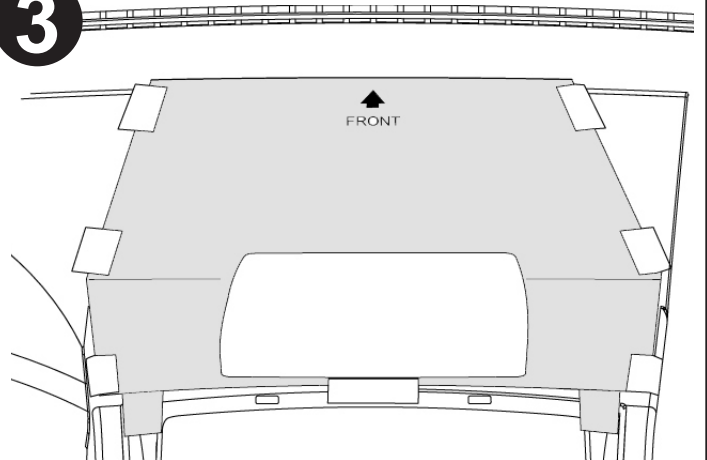
**3**

Secure on dash. ♦ Fixez-le sur le tableau de bord.

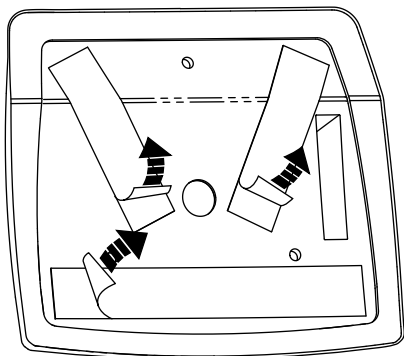
**4****B**

Remove tape liners from baseplate. ♦ Enlevez les bandes protectrices du socle.

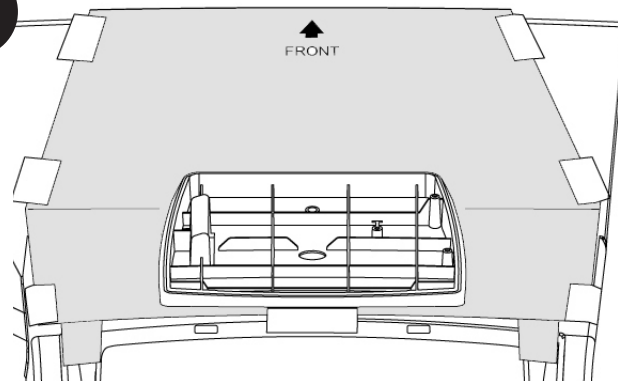
**5**

Place on dash. Press firmly 10 seconds. ♦ Placez-le sur le tableau de bord. Appuyez fermement pendant 10 secondes.

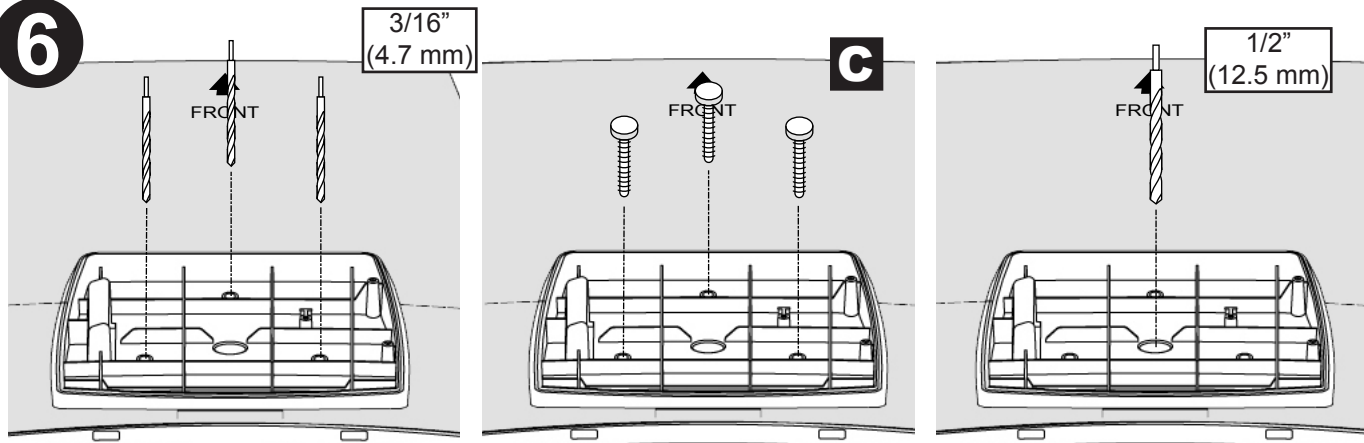
**6**

Drill Depth: 0.8" (20 mm) ♦ Profondeur de perçage : 20 mm (0,8 po)

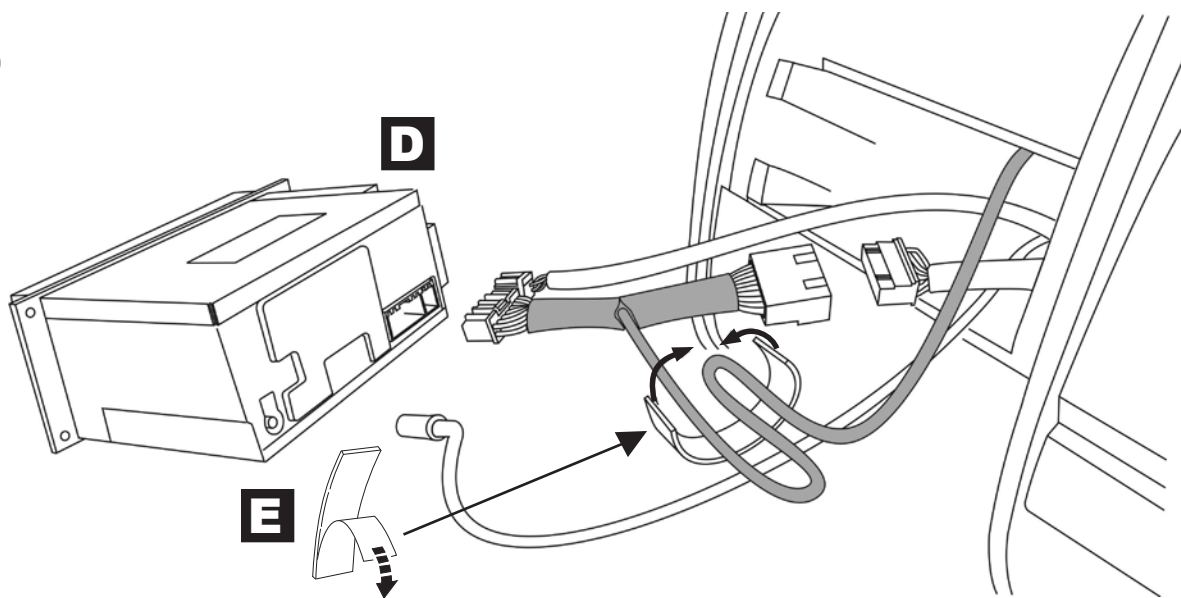
**7**

Route cables. ♦ Acheminez les câbles.  
Wrap foam tape around cables. ♦ Enveloppez la bande mousse autour des câbles.

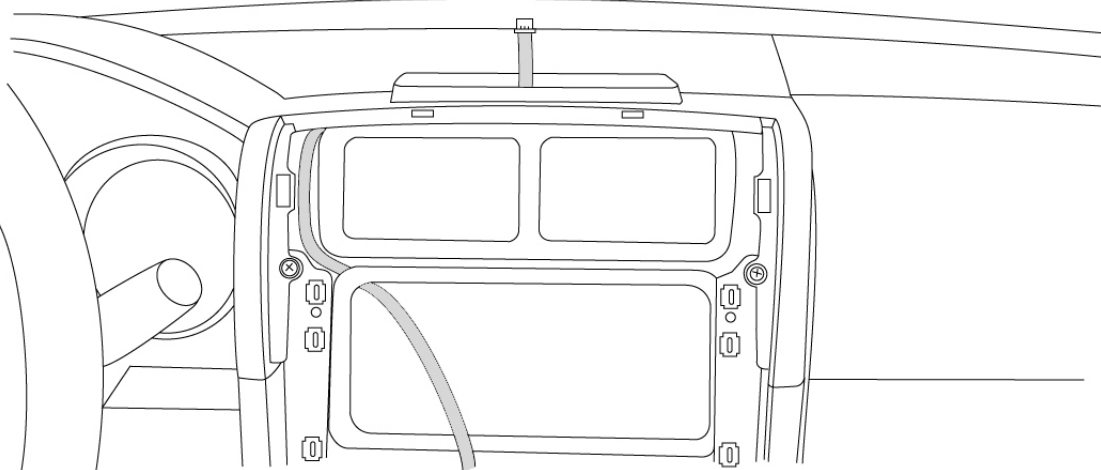
**8**

**9**

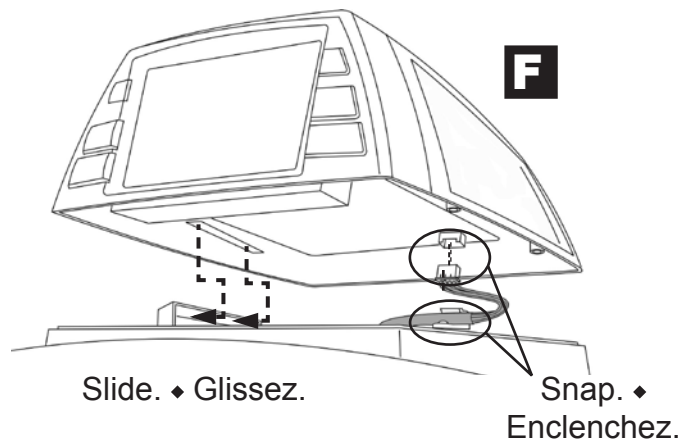

**10**

Screw down. Insert CF card. ♦ Vissez. Insérez la carte CF.

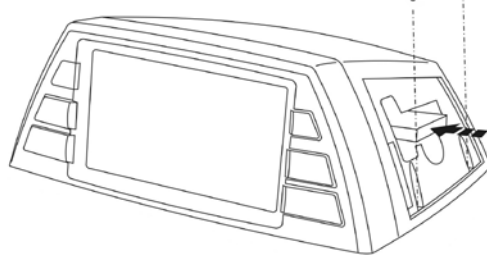
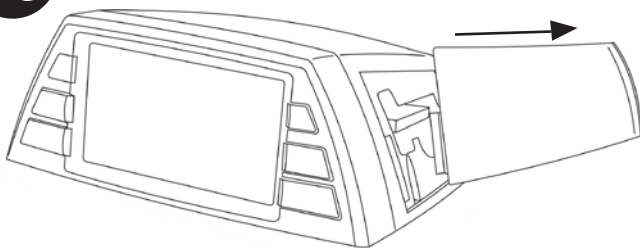

**G**

**H**