

GARMIN[™]

Owner's Manual

zūmo[™] 400/450



the personal motorcycle navigator

© 2006–2007 Garmin Ltd. or its subsidiaries

Garmin International, Inc.
1200 East 151st Street,
Olathe, Kansas 66062, USA
Tel. 913/397.8200 or 800/800.1020
Fax 913/397.8282

Garmin (Europe) Ltd.
Liberty House Hounslow Business
Park, Southampton, Hampshire,
SO40 9RB UK
Tel. +44 (0) 870.8501241
(outside the UK) or
0808 2380000 (UK only)
Fax 44/0870.8501251

Garmin Corporation
No. 68, Jangshu 2nd Road,
Shijr, Taipei County, Taiwan
Tel. 886/2.2642.9199
Fax 886/2.2642.9099

All rights reserved. Except as expressly provided herein, no part of this manual may be reproduced, copied, transmitted, disseminated, downloaded or stored in any storage medium, for any purpose without the express prior written consent of Garmin. Garmin hereby grants permission to download a single copy of this manual onto a hard drive or other electronic storage medium to be viewed and to print one copy of this manual or of any revision hereto, provided that such electronic or printed copy of this manual must contain the complete text of this copyright notice and provided further that any unauthorized commercial distribution of this manual or any revision hereto is strictly prohibited.

Information in this document is subject to change without notice. Garmin reserves the right to change or improve its products and to make changes in the content without obligation to notify any person or organization of such changes or improvements. Visit the Garmin Web site (www.garmin.com) for current updates and supplemental information concerning the use and operation of this and other Garmin products.

Garmin® is a trademark of Garmin Ltd. or its subsidiaries, registered in the USA and other countries. zūmo™, MapSource®, MyGarmin™, Garmin Travel Guide™, Garmin TourGuide™, and Garmin Lock™ are trademarks of Garmin Ltd. or its subsidiaries. These trademarks may not be used without the express permission of Garmin.



Windows® is a registered trademark of Microsoft Corporation in the United States and/or other countries. Mac® and iTunes® are registered trademarks of Apple Computer, Inc. The Winamp trademark is the property of Nullsoft, Inc. and its parent company, America Online, Inc. SiRF®, SiRFstar® and the SiRF logo are registered trademarks of SiRF Technology, Inc. SiRFstarIII™ and SiRF Powered™ are trademarks of SiRF Technology, Inc. Google™ and Google Earth™ are trademarks of Google Inc. RDS-TMC Traffic Information Services France © ViaMichelin 2006. Other trademarks and trade names are those of their respective owners.

PREFACE

Thank you for purchasing the Garmin® zūmo™.

Manual Conventions

When you are instructed to “touch” something, use your finger to touch an item on the screen. You will see arrows (>) used in the text. They indicate that you should touch a series of items. For example, if you see “touch **Where to > Favorites**,” you should touch the **Where to** button, and then touch **Favorites**.

Contact Garmin

Contact Garmin if you have any questions while using your zūmo. In the USA, contact Garmin Product Support by phone: 913/397.8200 or 800/800.1020, Monday–Friday, 8 AM–5 PM Central Time; or go to www.garmin.com/support, and click **Product Support**.

In Europe, contact Garmin (Europe) Ltd. at +44 (0) 870.8501241 (outside the UK) or 0808 2380000 (UK only).

myGarmin™

Go to <http://my.garmin.com> to access the latest services for your Garmin products. From the myGarmin Web site, you can:

- Register your Garmin unit.
- Subscribe to online services for safety camera information (see [page 42](#)).
- Unlock optional maps.

Return to myGarmin often for new Garmin product services.

About Google Earth™

Go to <http://earth.google.com> to download the Google Earth application. With Google Earth installed on your computer, you can view waypoints, tracks, and routes saved in MapSource®. From the View menu, select **View in Google Earth**.

Preface	i	Go Page Options.....	12
Manual Conventions.....	i	Go Home.....	12
Contact Garmin.....	i	Finding Points of Interest.....	12
myGarmin.....	i	Recently Found Locations.....	14
About Google Earth.....	i	Favorites.....	14
Important Information.....	iv	Creating a Saved Route.....	16
Getting Started	1	Finding a Location Using the Map..	18
Looking at Your zūmo.....	1	Entering Coordinates.....	19
Quick Links.....	2	Expanding Your Search.....	19
zūmo Tips and Shortcuts.....	2	Using the Main Pages	20
Adjusting the Volume.....	2	Map Page.....	20
Adjusting the Brightness.....	2	Trip Information Page.....	21
Mounting the zūmo on Your		Turn List Page.....	22
Motorcycle.....	3	Next Turn Page.....	22
Configuring Your zūmo.....	7	Traffic Information	23
Acquiring Satellites.....	7	Viewing Traffic Incidents.....	23
Using Your zūmo.....	7	Avoiding Traffic.....	23
Finding Your Destination.....	8	Purchasing Traffic Subscriptions....	24
Following Your Route.....	9	Managing Files on Your zūmo	25
Adding a Stop to Your Route.....	9	Supported File Types.....	25
Adding a Detour.....	10	Deleting zūmo Files.....	27
Stopping the Route.....	10	Using the Media Player	28
Taking a Better Route.....	10	Listening to MP3 Files.....	28
Locking Your zūmo.....	10	Customizing the zūmo	30
Where to	11	Changing the Map Settings.....	30
Finding an Address.....	11		

Changing the System Settings	31
Localizing Your zūmo	32
Managing User Data	33
Changing the Navigation Settings ..	34
Customizing the Display	35
Changing the Keyboard	35
Managing Traffic Settings	36
Restoring All Settings	36
Clearing All User Data	36
Appendix	37
zūmo Audio Options	37
Charging the zūmo	37
Automotive Mount Accessory	37
Updating the zūmo Software	39
Purchasing and Loading Additional Map Data	40
Optional Accessories	40
Battery Information	44
Using a Remote Antenna	45
About GPS Satellite Signals	45
Specifications	46
zūmo Troubleshooting	47
USB Interface Troubleshooting	48
Index	50



Important Information

Product Warnings

When your zūmo is not in the motorcycle mount, use the weather cap to prevent damage to the connector.

See the *Important Safety and Product Information* guide for product warnings and legal information.

Tips for Protecting Your zūmo

- Carry and store your zūmo in the included carrying case (zūmo 450 only).
- Do not store your zūmo where prolonged exposure to extreme temperatures can occur (such as in the trunk of a car), because it can cause permanent damage.
- Though a PDA stylus can also be used to operate the touch screen, never attempt this while operating a vehicle. Never use a hard or sharp object to operate the touch screen or damage may result.
- Avoid dropping your unit and operating it in extreme high-shock and high-vibration environments. Your zūmo contains sensitive electronic components that can be permanently damaged if exposed to excessive shock or vibration outside normal motorcycle use.
- To avoid theft, remove the zūmo and mount from sight when not in use.
- Use the Garmin Lock™ feature. See [page 10](#).

Declaration of Conformity





Hereby, Garmin declares that this product is in compliance with the essential requirements and other relevant provisions of Directive 1999/5/EC.

To view the full Declaration of Conformity, see the Garmin Web site for your Garmin product: www.garmin.com/products/zumo400 or www.garmin.com/products/zumo450. Click **Manuals**, and then select the **Declaration of Conformity**.





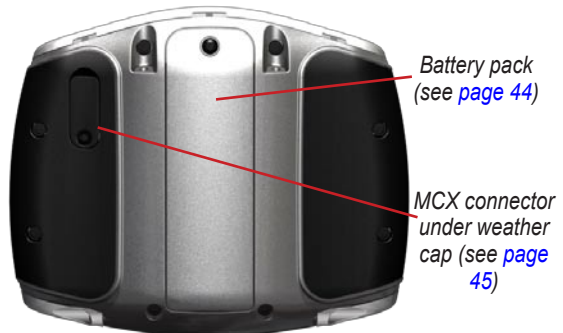
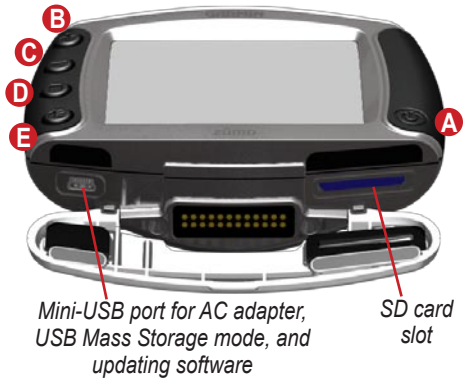

GETTING STARTED

Looking at Your zūmo





- A.  Power button
- B.  Zoom in, raise volume, or increase brightness.
- C.  Zoom out, lower volume, or decrease brightness.
- D.  Page button—scroll through the Map, Trip Information, and Media Player pages. Press and hold to adjust brightness.
- E.  Speak button—press to adjust volume level. Press and hold to announce voice directions.





zūmo Tips and Shortcuts

- Touch and hold  to quickly return to the Menu page.
- Press  to return to the Map page.
- Touch  and  to see more choices.
- Touch  to adjust settings such as volume, brightness, language, and keyboard.

Adjusting the Volume

Press , and then use  and  to adjust the volume. For advanced volume settings, touch  >  **Volume**.

Adjusting the Brightness

Press and hold , and then use  and  to adjust the brightness. See [page 35](#) for additional display settings.

Quick Links

- Finding an address: [page 11](#)
- Viewing the Map page: [page 20](#)
- Using the Garmin Lock™ anti-theft feature: [page 10](#)
- Listening to MP3 files: [pages 28–29](#)
- Transferring files to your zūmo: [pages 25–27](#)
- zūmo audio options: see [page 37](#)
- Frequently asked questions: [page 47](#)

Mounting the zūmo on Your Motorcycle



WARNING: The terms of the Garmin Warranty require that the power cable with bare wire leads be installed by experienced installers having the proper knowledge of automotive electrical systems and skill in the use of special tools or hardware required for installation.

1: Connect Power to the Mount

Select a suitable and secure location to mount the zūmo on your motorcycle based on available power sources and safe cable routing.



About Connecting Audio

Standard jacks for microphone (2.5 mm) and audio out (3.5 mm) are located on the left side of the mount (under a weather cap). When connecting your audio system to the zūmo, be sure to consider the pathways needed to route the necessary cables. For more information, see [page 37](#).

2: Install the Handlebar Base

The zūmo includes parts for two handlebar installation solutions. Custom mounts can require additional hardware (www.ram-mount.com).

A) To install the U-bolt and handlebar base:

1. Place the U-bolt around the handlebar, and thread the ends through the handlebar base.
2. Tighten the nuts to secure the base. Do not overtighten.

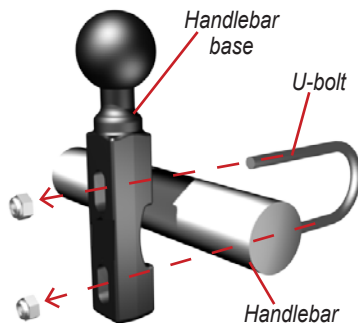

NOTE: The recommended torque is 50in-lb (5.7 N-m). Do not exceed maximum torque of 80in-lb (9 N-m).

B) To install the handlebar base to the clutch/brake clamp bracket:



NOTE: Both 1/4" standard and M6 bolts are included. Match the size of the factory bolts on your clutch/brake clamp bracket.

1. Remove the two factory bolts on your clutch/brake clamp bracket.
2. Thread the new bolts through the handlebar base, spacers, and clamp bracket.
3. Tighten the bolts to secure the base.

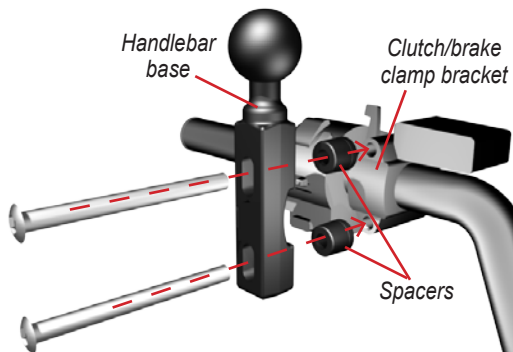

3: Attach the Base Plate to the zūmo Mount

1. Thread the M4 x 40 mm flathead bolts and nuts to attach the base plate to the zūmo mount.
2. Tighten the nuts to secure the base plate.

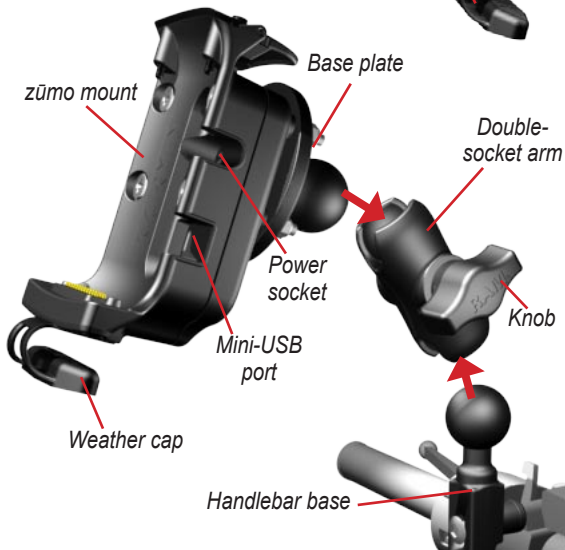
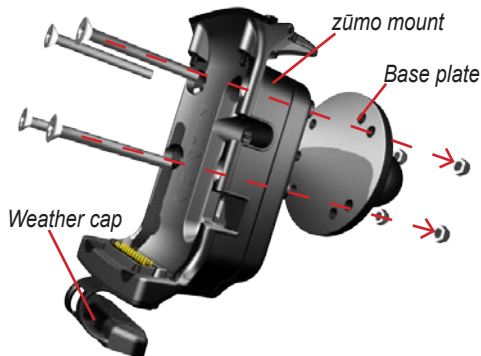

4: Attach the Base Plate to the Handlebar Base

1. Align the ball of the handlebar base and the ball of the base plate with the double-socket arm.
2. Tighten the knob slightly.
3. Adjust for better viewing and operation.
4. Tighten the knob to secure the mount.

5: Install the zūmo in the Mount

1. Plug the power cable into the zūmo mount. For a better seal, tighten the screws on the power connector.
2. Flip the lever up.
3. Flip the weather cap down and under (magnetic).
4. Place the zūmo into the mount, and flip the lever down.
5. Tighten the security screw.



About the Security Screwdriver

Use the security screw to better secure the zūmo to the mount. You can connect the screwdriver to your key chain for easy access.



Configuring Your zūmo

To turn on your zūmo, press and hold . Follow the on-screen instructions to configure your zūmo.

Acquiring Satellites

Go outdoors to an open area, out of garages, and away from tall buildings. Turn on the zūmo. Acquiring satellite signals may take a few minutes.

The  bars indicate GPS satellite strength. When the bars are green, your zūmo has acquired satellite signals, and you can start navigating.

Using Your zūmo

- A.** Displays satellite strength.
- B.** Displays battery status.
- C.** Touch to find a destination.
- D.** Touch to view the Map page.
- E.** Touch to view traffic incidents (requires receiver and subscription).
- F.** Touch to open the Media Player.
- G.** Touch to adjust the zūmo's settings.

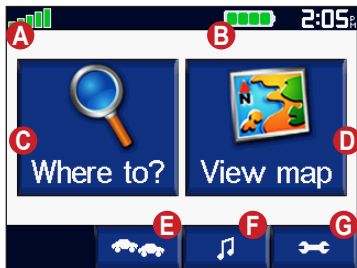

Finding Your Destination

The  Where to menu provides several different categories for you to use when you search for locations.

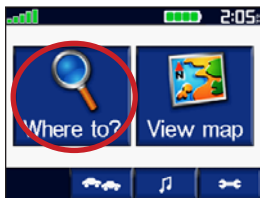

1 Touch  **Where to.**



2 Select a category.



3 Select a sub-category.

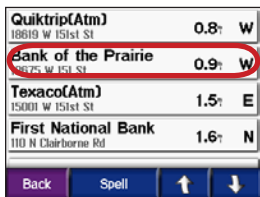

4 Select a destination.

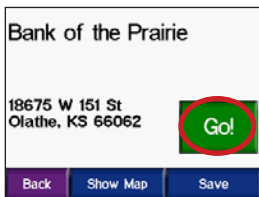

5 Touch **Go.**



6 Enjoy the route!

TIP: Touch  and  to see more choices.

Following Your Route

As you travel, your zūmo guides you to your destination with voice prompts, arrows on the map, and directions at the top of the Map page. If you depart from the original route, your zūmo recalculates the route and provides new directions.



Your route is marked with a purple line.



Follow the arrows as you take turns.



A checkered flag marks your destination.

Adding a Stop to Your Route

You can add a stop to your route. The zūmo gives you directions to the stop and then to your final destination.

1. With a route active, touch **Menu** on the Map page, and touch  **Where to**.
2. Search for the extra stop.
3. Touch **Go**.
4. Touch **Add as Via Point** to add this stop before your destination. Touch **Set as new Destination** to make this your new final destination.

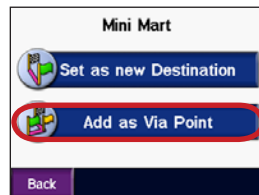

Adding a Detour





If a road on your route is closed, you can take a detour.

1. With a route active, touch **Menu**.
2. Touch **Detour**.



Stopping the Route

1. With a route active, touch **Menu**.
2. Touch **Stop**.

Taking a Better Route

As you approach your destination, the zūmo evaluates road options, to find a better route. If the zūmo finds a better route,  or  appears in the right corner of the map. Touch  or  to take the better route.

Locking Your zūmo

1. Touch  >  **System** > **Garmin Lock**.
2. Touch **OK**, and enter a four-digit PIN.
3. Re-enter your four-digit PIN.
4. Touch **OK**.
5. Drive to a security location, and touch **Set**.

Each time you turn on the zūmo, enter your PIN or drive to the security location.

What is a Security Location?

If you are at your security location, you do not need to enter your PIN. If you forget your PIN, acquire satellite signals and then drive to your security location to unlock the zūmo.





NOTE: If you forget your PIN and your security location, you must send your zūmo to Garmin to get it unlocked.

WHERE TO

The Where to menu provides several different categories you can use to search for locations.

Finding an Address

1. Touch  **Where to** >  **Address**.
2. Select a country, state/province, and city/postal code, if necessary.
3. Enter the address number, and touch **Done**.
4. Enter the street name until a list of streets appears, or touch **Done**.
5. Select the street and city, if necessary.
6. Select the address, if necessary. The Go page opens.
7. Touch **Go** to create a route to this address.

TIP: Do not enter the street prefix or suffix. For example, to find North Main Street enter Main, and to find Highway 7 enter 7.

About Postal Codes

You can search for a postal code. Enter the postal code instead of the city name. Not all map data provides postal code searching.

Intersections

Finding an intersection is very similar to finding an address. Touch  **Intersection**, and enter the two street names.

Go Page Options

Touch an item in the search results list to view the Go page.

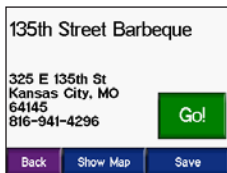



Touch **Go** to create a turn-by-turn route to this location.

Touch **Show Map** to view this location on the map. If the GPS is off, touch **Set Loc.** to set this as your current location.

Touch **Save** to save this location as one of your Favorites. See [page 14](#).

Go Home

You can set a home location for the place you return to most often.



1. Touch  **Where to** >  **Go Home**.
2. Select an option.

Going Home



After you set your home location, you can route to it at any time by touching

 **Where to** >  **Go Home**.

Changing Your Home Location



1. Touch  >  **User Data** > **Set Home Location**.
2. Select **Yes, enter my Address** or **Yes, use my current location**.

Finding Points of Interest

1. Touch  **Where to** >  **Food, Lodging**.
2. Select a category and a sub-category, if necessary. (Touch the arrows to see more categories.)
3. Select a destination.
4. Touch **Go**.

Finding a Location by Spelling the Name



If you know the name of the location you are looking for, you can spell it using the on-screen keyboard. You can also enter letters contained in the name to narrow the search.

1. Touch  **Where to** >  **Food, Lodging.**
2. Touch **Spell Name.**
3. Using the on-screen keyboard, enter letters in the name. Touch **Done.**
4. Touch the location you are looking for, and touch **Go.**

Using the On-Screen Keyboard

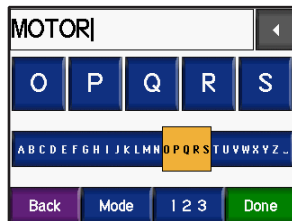
When an on-screen keyboard appears, touch and slide the yellow box to scroll through the characters. Touch a character to enter it.



Touch  to delete the last character entered; touch and hold  to delete the entire entry.



Touch  to change the keyboard mode to use diacritical characters or special characters.

Touch  to enter numbers.

To change the keyboard display, see [page 35](#).

Recently Found Locations

Your zūmo stores the last 50 of your recent finds in the Recently Found list.

The most recently viewed locations appear at the top of the list. Touch  **Where to** >  **Recently Found** to view your recently found items.

Touch **Save** > **OK** to add a recently found location to your Favorites.

Touch **Clear** > **Yes** to delete all locations from the Recently Found list.



NOTE: When you delete recently found locations, all items are removed from the list. It does not delete the actual location from your unit.

Favorites



You can save up to 500 locations in your Favorites, so you can quickly find them and create routes to them. Your home location is also stored in Favorites.

Saving Locations You Find

1. After you have found a location you want to save, touch **Save**.
2. Touch **OK**. The location is saved in  **Favorites**.

Sharing Locations

Share your Favorites with other zūmo owners. You must have an SD card inserted with available storage space.

1. Touch  **Where to** >  **Favorites**.
2. Select the location you want to share.
3. Touch **Share**.



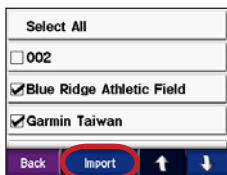

- Verify that the correct location is selected, and then touch **Export**.
- Touch **OK**.
- Eject your SD card, and insert it into another zūmo.
- A message appears. Touch **Yes** to import the shared locations.
- Touch  **Favorites**, and then touch the location you want to import.



- Touch **Import**, and then touch **OK**.
- Touch **Done** to go back to the Menu page.



Finding Saved Locations

Touch  **Where to** >  **Favorites**. The locations are listed by distance from your current location. Touch **Spell** to narrow your search.

Saving Your Current Location

From the Map page, touch the  vehicle icon. Touch **Yes** to save your current location as a Favorite.

Editing Saved Locations

- Touch  **Where to** >  **Favorites**.
- Touch the location you want to edit.
- Touch **Edit**.





- To edit the location:
Touch **Change Name**. Enter a name, and touch **Done**.
Touch **Change Map Symbol**. Touch a symbol.

Touch **Change Phone Number**. Enter a phone number, and touch **Done**.



Touch **Delete** to remove this item. A list of all your Favorites appears. Touch the item you want to delete. Touch **Delete** > **Yes**.

Creating a Saved Route



Use your zūmo to create and save routes before your next trip. You can save up to 50 routes.

1. Touch  **Where to** >  **Routes** > **New**.
2. Touch **Add New Start Point**.
3. Find a location as your starting point, and touch **Select**.
4. Touch **Add New End Point**.
5. Find a location as your ending point, and touch **Select**.



6. Touch  to add another location to your route. **TIP:** Use the **Near** button to narrow your search, see [page 19](#). Touch  to remove a location.
7. Touch **Map** to calculate your route, and view it on the map.
8. Touch **Back** to exit and save the route.

Editing Saved Routes

1. Touch  **Where to** >  **Routes**.
2. Select the route you want to edit.
3. Touch **Edit**.



4. To edit the route:

Touch **Change Name**. Enter a new name, and touch **Done**.

Touch **Add/Remove Points** to add new start, stop, or end points to the route.

Touch **Manual Reorder** to change the order of points along your route.

Touch **Optimal Reorder** to automatically order the points according to straight line distance between your start and end points.

Touch **Recalculate** to change the route preference to calculate by faster time, shorter distance, or off road.



Touch **Delete** to remove this item. A list of all your routes appears. Touch the item you want to delete. Touch **Delete > Yes**.



NOTE: Your changes are automatically saved when you exit any of the route edit pages.

Sharing Routes

Share your saved routes with other zūmo owners. You must have an SD card inserted with available storage space.

1. Touch  **Where to >**  **Routes**.
2. Select the route you want to share.
3. Touch **Share**.

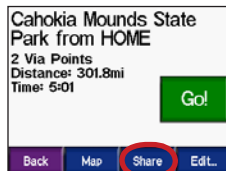

4. Verify that the correct route is selected, and then touch **Export**.
5. Touch **OK**.
6. Eject your SD card, and insert it into another zūmo.
7. A message appears. Touch **Yes** to import the shared route.
8. Touch **Routes**, and then touch the route you want to import.

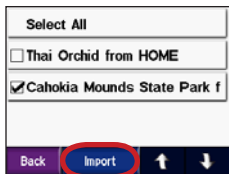

9. Touch **Import**, and then touch **OK**.
10. Touch **Done** to go back to the Menu page. To view your imported routes, touch **Where to** > **Routes**.



NOTE: You can also share routes using Google Earth. Go to <http://earth.google.com>.

Finding a Location Using the Map

Touch **View map** to open the Map page. Touch and drag anywhere on the Map page to browse the map and view different parts of the map. You can also touch **Where to** > > **Browse Map**.

Tips for Browsing the Map

- Touch the map and drag to view different parts of the map.
- Touch and to zoom in and out.
- Touch any object on the map. An arrow appears pointing at the object you selected.
- Touch **Back** to return to the previous screen.
- Touch **Save** to save this location to your Favorites.
- Touch **Go** to create a turn-by-turn route to the location.
- If the GPS is off, touch **Set Loc.** to set the arrow location as your current location.

Entering Coordinates

If you know the geographic coordinates of your destination, you can use your zūmo to navigate to any location using its latitude and longitude coordinates.

Touch  **Where to** >  >  **Coordinates**.



Touch **Format** to change the type of coordinates. Because different maps and charts use different position formats, the zūmo allows you to choose the correct coordinate format for the type of map you are using.

Touch **Next** for more options:

- Touch **Go** to create a turn-by-turn route to the coordinates.
- Touch **Show Map** to view this location on the map.

- Touch **Save** to save this location to your Favorites.

Expanding Your Search

1. Touch  **Where to** > **Near**.
2. Select an option:

Where I Am Now—searches near your current location.

A Different City—searches near the city you specify.

My Current Route—searches along the route you are currently navigating.

My Destination—searches for locations near your current route destination.

3. Touch **OK**.



NOTE: Your zūmo automatically searches near your current location.

USING THE MAIN PAGES

Map Page

On the Menu page, touch  **View map** to open the Map page. The  vehicle icon shows your current location.

To save your current location, touch the vehicle icon, and touch **Yes**.

Touch the directions bar to open the Turn List page.

Touch  to zoom out.

Touch  to zoom in.

Touch **Menu** to return to the Menu page.

Touch **Speed** to open the Trip Information page.

Touch **Turn In** to open the Next Turn page.

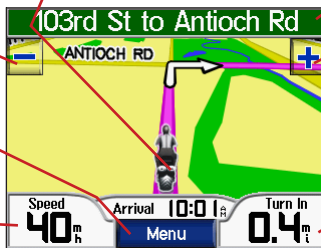

Map Page while Navigating a Route



Trip Information Page

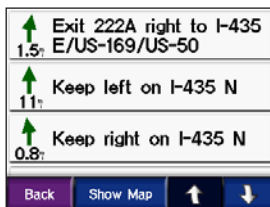

Turn List Page

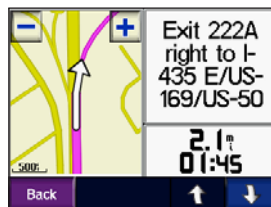

Next Turn Page

Trip Information Page

The Trip Information page shows your current speed and provides helpful statistics about your trip. To view the Trip Information page, touch **Speed** on the Map page.

Resetting Trip Information

If you want accurate trip information, reset the trip information before beginning a trip. If you make frequent stops, leave the zūmo turned on so it can accurately measure elapsed time during the trip.

Touch **Reset > Trip Data** to reset the odometer and time information.

Touch **Reset > Max Speed** to reset the maximum speed.

Touch **More** to view total time, moving time, and stopped time.

Using the Fuel Gauge

The fuel gauge is for motorcycle use only. You can track your fuel usage when the zūmo is in the motorcycle mount. The fuel gauge is only as accurate as the data you enter.

1. On the Map page, touch **Speed** to open the Trip Information page.
2. Touch **Reset > Miles Per Tank**.
3. Enter an amount, and touch **Done**.
4. A message appears when you have 30 miles (~48.3 km) remaining.
5. On the Map page, touch the  icon to search for a nearby fuel station.
6. To reset the fuel gauge, go to the Trip Information page, and touch the fuel gauge > **Yes**.



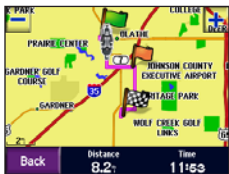

Turn List Page

When you are navigating a route, the Turn List page shows turn-by-turn instructions for your entire route and the distance between turns. Touch the directions bar on the top of the Map page to open the Turn List page. Touch a turn on the list to view the Next Turn page for that turn. Touch **Show Map** to view the entire route on the map.



Next Turn Page

When you are navigating a route, the Next Turn page shows the turn on the map and the distance and time left before you reach the turn. To view an upcoming turn on the map, touch **Turn In** on the Map page, or touch any turn from the Turn List page.

Touch  and  to view other turns in the route. When you are finished viewing the Next Turn page, touch **Back**.

TRAFFIC INFORMATION

Your zūmo can receive and use traffic information using an optional FM TMC (Traffic Message Channel) traffic receiver. When a traffic message is received, your zūmo displays the incident on the map and can change your route to avoid the traffic incident.



NOTE: Garmin is not responsible for the accuracy of the traffic information. The traffic receiver simply receives signals from the traffic service provider and displays that information on your zūmo.



Traffic icon for North America



Traffic icon for Europe



Viewing Traffic Incidents





NOTE: You can only access the traffic information if the zūmo is connected to a traffic receiver (see [page 41](#)).

1. On the Menu page, touch  > **Traffic** to show traffic incidents.
2. Select an item to view details.
3. Select an option.

Avoiding Traffic

The Map page displays  or  when there is a traffic incident on your current route or on the road on which you are traveling.





1. From the Map page, touch  or .

2. Select an item to view details.
3. Touch **Avoid**.

Purchasing Traffic Subscriptions

You can renew and purchase new subscriptions at www.garmin.com/fmtraffic.

Adding a Subscription

1. Touch  >  >  **Traffic**.
2. Touch **Subscriptions** > **Add**.
3. Follow the on-screen instructions.



NOTE: Additional documentation is included with your Garmin traffic receiver.

FM Traffic

For more information about an FM traffic receiver, go to www.garmin.com/traffic. For participating FM traffic subscription providers and coverage cities, go to www.garmin.com/fmtraffic.



NOTE: The FM traffic receiver and zūmo must be in data range of an FM station transmitting TMC data to receive traffic information.

MANAGING FILES ON YOUR zūMO

You can load files to the internal memory or an optional SD card.



NOTE: The zūmo is not compatible with Windows® 95, Windows 98, or Windows Me operating systems. This is a common limitation of most USB Mass Storage Devices.

Supported File Types

- MP3 music files
- JPEG and JPG image files for splash screen or picture viewer
- GPI custom POI files from Garmin's POI Loader
- GPX waypoint files and maps from MapSource



NOTE: The zūmo does not support iTunes® M4A/M4P files.

Step 1: Insert an SD Card (Optional)

To insert or remove the card, press it in until it clicks.

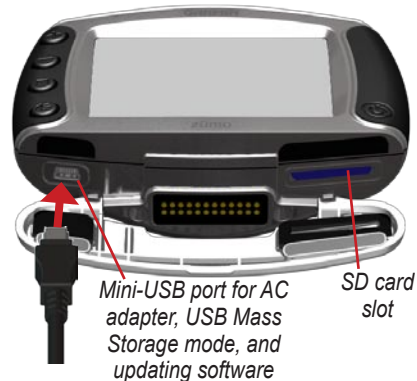

Step 2: Connect the USB Cable

1. Plug the small end of the USB cable into the mini-USB port.
2. Connect the larger end of the USB cable to an available USB port on your computer.

Two additional drives appear in your computer's list of drives. "Garmin" is the available storage in the zŪmo's internal memory. The other removable disk drive is the SD card.



NOTE: If the drive is not named automatically, see your Help file or [page 49](#) to rename the drive.

Step 3: Transfer Files to Your zŪmo

For Windows

1. Connect the zŪmo to your computer.
2. Double-click  **My Computer**.
3. Browse your computer for the file you want to copy.
4. Highlight the file, and select **Edit > Copy**.
5. Open the Garmin drive or the SD card drive.

6. Select **Edit > Paste**. The file appears in the list of files on the Garmin or SD card drive.



NOTE: You can also drag and drop files to and from your drives.

For Mac®

1. Connect the zŪmo to your computer. Your Garmin and SD card drives should mount onto your Mac desktop as two mounted volumes.
2. To copy files to your Garmin or SD card drive, drag and drop any file or folder onto the volume icon.





Step 4: Eject and Unplug

For Windows

When you are finished transferring files, double-click the  **Unplug or Eject** icon in your Windows system tray.

Select **USB Mass Storage Device**, and click **Stop**. Select the drive, and click **OK**. You can unplug the USB cable from your zūmo now.

For Mac

When you are finished transferring files, drag the volume icon to the **Trash**  (it turns into an **Eject**  icon) to unmount the device. You can unplug the USB cable from your zūmo now.

Deleting zūmo Files

You can delete files from your zūmo just as you would delete files from your computer.

Connect the zūmo to your computer, and open your Garmin or SD card drive. Select the file that you want to delete, and press the **Delete** key on your computer's keyboard.



CAUTION: If you are not sure about a file's purpose, do **not** delete it. Your zūmo memory contains important system files that should **not** be deleted. Be cautious of files located in folders entitled "Garmin."

USING THE MEDIA PLAYER

Listening to MP3 Files

Load MP3 files to the internal memory or an optional SD card. See [pages 25–27](#) for more information.

1. On the Menu page, touch  to open the Media Player.
2. Touch **Browse**.
3. Touch a category. You view a list of all MP3 files or view by album, artist, or genre.
4. To play the entire category from the beginning of the list, touch **Play All**. To play all starting with a specific song, touch the title.





Album art

Touch the album art to view details about the MP3 file.

Touch  to adjust the volume. For zūmo audio options, see [page 37](#).

Tap  to go to the beginning of the song; touch and hold to skip back.

Tap  to skip to the next song; touch and hold to skip ahead.

Touch  to pause the song.

Touch  to repeat.

Touch  to shuffle.



NOTE: The zūmo plays MP3 files only; it does not support iTunes® M4A/M4P files.

Using a Playlist

This feature involves managing files on your zūmo (see [pages 25–27](#)).

1. Using your computer and an audio program such as Winamp™, create a playlist of MP3 files.
2. Save the playlist as an M3U file.



NOTE: You may need to edit the M3U file with a text editor, such as Notepad, to remove the path (location) to the MP3. The M3U file should only list the MP3 files in your playlist, not their location. Refer to the audio program's Help file for instructions.

3. Transfer the playlist and the associated MP3 files to the Garmin or SD card drive. The M3U file must be in the same location as the MP3 files.
4. On the zūmo, touch  to open the MP3 player.

5. Touch **Browse** > **Import Playlist**.
The available playlists appear.

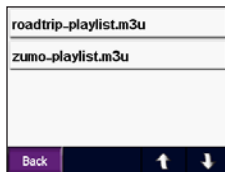

6. Touch a playlist to start playing the MP3 files.



NOTE: You cannot change the order of the playlist from your zūmo.

CUSTOMIZING THE ZŪMO

1. From the Menu page, touch .
2. Touch the setting you want to change. Each setting contains a submenu or a list.



Changing the Map Settings

Touch  >  **Map**.

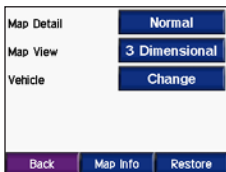

Map Detail—adjust the amount of detail shown on the map. Showing more detail may cause the map to redraw slower.

Map View—change the perspective of the map.

- **Track Up**—display the map in 2 dimensions (2D) with your direction of travel at the top.
- **North Up**—display the map in 2D with North at the top.
- **3D**—display the map in 3 dimensions (3D) in Track Up.

Vehicle—touch **Change** to change the icon used to show your position on the map. Touch the icon you want to use, and then touch **OK**. Download additional vehicle icons at www.garmin.com/vehicles.

Map Info—view the maps loaded on your zūmo and their version. Touch a map to enable (check mark) or disable (no check mark) that map.

Restore—restore the default map settings.

Changing the System Settings

Touch  >  **System.**

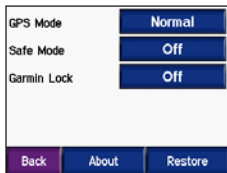

GPS Mode—enable and disable GPS and WAAS/EGNOS. Turning on the WAAS/EGNOS setting might improve GPS accuracy, but it consumes more battery power. Go to www.garmin.com/aboutGPS/waas.html for information about WAAS/EGNOS.

Safe Mode—turn Safe Mode on or off. When your vehicle is moving, Safe Mode disables all functions that require significant operator attention and could become a distraction while driving.

Garmin Lock—turn on Garmin Lock to lock your zūmo. Enter a 4-digit PIN, and set a security location. For more information, see [page 10](#).

About—display your zūmo’s software version number, unit ID number, and audio version number. You need this information when you update the system software (see [page 39](#)) or purchase additional map data (see [page 40](#)).

Restore—restore the default system settings.

Localizing Your zūmo

Touch  >  **Locale**.





To change a setting, touch the button next to the icon.

To change all settings, touch **Change All**. In each screen, select the setting, and then touch **OK**.

Locale—select your location.

 **Text Language**—set all on-screen text to the selected language. Changing the text language does not change the language of user-entered data or map data, such as street names.

 **Voice Language**—set the language for voice prompts.

 **Time Format**—choose a 12-hour, 24-hour, or UTC time format.

Time Zone—select a time zone or nearby city from the list.

Daylight Saving—set to **On**, **Off**, or **Auto**, if it is available.

 **Units**—set units of measure to **Kilometers** or **Miles**.

Managing User Data

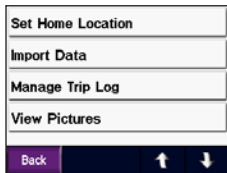

Touch  >  **User Data**.



Set Home Location—enter or change your home location. See [page 12](#).

Import Data—load Favorites, routes, trip logs, and pictures from your Garmin drive or SD card.

Manage Trip Log—view the current trip log usage. The zūmo stores your last 10,000 points of trip data. At the start of your next big trip, you may want to reset the trip log. Touch **Clear Trip Log**. Clearing a large trip log may take a few minutes. You can also reuse recent trip information. Touch **Save As Route** to select and save a recent trip segment as a route. For more information about routes, see [page 16](#).

View Pictures—view pictures saved to your Garmin drive or SD card. Touch a thumbnail to view the image. Touch the image again to zoom using  and . Touch the picture and drag to view different parts of the picture.

To share pictures with another zūmo user:

1. Touch a thumbnail.
2. Touch **Share**.



3. Verify that the correct picture is selected, and then touch **Export**.
4. Eject your SD card, and insert it into another zūmo.
5. A message appears. Touch **Yes** to import the shared picture.
6. Touch **Pictures** > touch a thumbnail > **Import**.

- Verify that the correct picture is selected, and then touch **Import**.

Touch **Slide Show** to display each image for a few seconds and then display the next image. During the slide show, touch the screen at any time to stop and see more options.

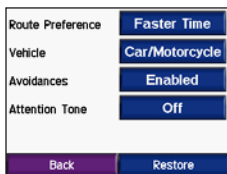

Changing the Navigation Settings

Touch  >  **Navigation**.



Route Preference—select a preference for calculating your route:

- Faster Time**—to calculate routes that are faster to drive but can be longer in distance.
- Shorter Distance**—to calculate routes that are shorter in distance but can take more time to drive.

- Off Road**—to calculate point-to-point routes (without roads). On the Map page, touch  or press  to scroll to the Compass page.

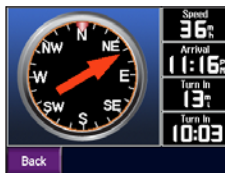

Vehicle Type—specify your vehicle type to optimize routes.

Avoidances—select the road types you want to avoid on your routes. The zümo uses these road types only if alternative routes take you too far out of your way or if no other roads are available. If you have a traffic receiver, you can also avoid traffic incidents.

Attention Tone—turn on or off the attention tone.

Restore—restore the default navigation settings.

Customizing the Display

Touch  >  **Display**.

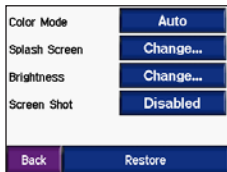

Color Mode—select **Daytime** for a light background, **Nighttime** for a dark background, or **Auto** to automatically switch between the two.

Splash Screen—select an image to be shown when you turn on the zümo. First, load JPEG images. See [pages 25–27](#).

Brightness—raise and lower the backlight brightness using **–** and **+**.

Screen Shot—enable Screen Shot mode. Touch the  camera icon to take a picture of the screen. The picture bitmap file is saved in the **Garmin\scrn** folder on the Garmin drive.

Changing the Keyboard

Touch  >  **Keyboard**.



Standard—displays a full alphabetic keyboard.



Large Buttons—displays a large button touch-screen keyboard. This option is suited for motorcyclists wearing gloves. See [page 13](#).

Auto—select to automatically switch between the standard keyboard when using the zümo in the automotive mount (optional accessory) and the large button keyboard when using the zümo in the motorcycle mount.

Managing Traffic Settings

Touch  >  >  **Traffic** to view FM traffic subscription information and settings. You must have a traffic receiver connected to the unit (see [pages 23–24](#)).

Restoring All Settings

1. From the Menu page, touch .
2. Touch **Restore**, and then touch **Yes**. This restores all of your zūmo settings to the factory defaults.

Clearing All User Data



CAUTION: This deletes all user-entered information including Favorites, routes, trip logs, settings, and recent finds.

1. Hold your finger on the lower-right corner of the zūmo's screen while turning on the zūmo.
2. Keep your finger pressed until the pop-up window appears.
3. Touch **Yes** to clear all user data.

APPENDIX

zūmo Audio Options

Connect your headphones or headset to the zūmo to hear navigation prompts and MP3s.



NOTE: For all audio features, you must have an external power source connected to the zūmo mount.

Charging the zūmo

1. Connect the power cable to the mount and a power source.
2. Place the zūmo in the mount, and flip the lever down.

Automotive Mount Accessory

You can purchase an additional mount for your automobile. Select a suitable location in your vehicle for safe cable routing and safe operation. Clean and dry the selected area of your windshield.

Mounting on Your Windshield

1. Place the suction cup on the windshield. Flip the suction lever back, toward the windshield.



2. Plug the power cable into the side of the mount.
3. Place the zūmo into the automotive mount, and flip the lever down.



4. Plug the power cable into a power receptacle in your vehicle. Your zūmo should turn on automatically if the vehicle is running.

Mounting on Your Dashboard

Use the mounting disk to mount your zūmo on the dashboard and to comply with state regulations.



NOTE: The **permanent** mounting adhesive is extremely difficult to remove after it is installed.

1. Clean and dry the dashboard where you want to place the disk.
2. Remove the backing from the permanent mounting adhesive on the bottom of the disk.
3. Place the disk on the dashboard.
4. Place the suction cup part of the automotive mount on top of the disk.
5. Flip the suction lever down (toward the disk).

Removing the zūmo from the Mount

To remove the zūmo from the mount, flip up the lever on the mount. Lift out the zūmo.

You can separate the suction cup from the automotive mount. Turn the mount as far as you can to the right or left. Apply pressure in that direction until the mount snaps off the arm.



NOTE: Reconnecting the suction cup to the automotive mount requires significant force. Press the ball end firmly into the socket.

To remove the suction cup from the windshield or mounting disk, flip the suction lever up. Pull the tab on the suction cup toward you.

Updating the zūmo Software

1. Go to www.garmin.com/products/webupdater to download the WebUpdater program to your computer.
2. Connect the zūmo to your computer using the mini-USB cable.

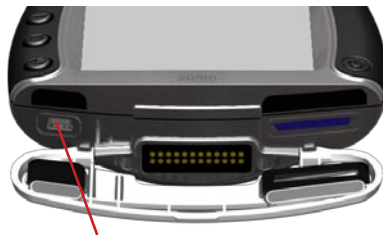

Mini-USB port for AC adapter, USB Mass Storage mode, and updating software



3. Run WebUpdater, and follow the screen prompts. After confirming that you want to perform an update, WebUpdater automatically downloads the update and installs it on your zūmo.

4. Eject and unplug your zūmo (see [page 27](#)).

Register your zūmo to receive notification of software and map updates. To register your zūmo, go to <http://my.garmin.com>.

You can also download software updates from www.garmin.com/products/zumo400 or www.garmin.com/products/zumo450. Click **Updates and Downloads**, and follow the instructions.

Purchasing and Loading Additional Map Data

To find out the version of the maps that are loaded on your zūmo, touch  >  **Map** > **Map Info**. To unlock additional maps, you need your unit ID and serial number.

Check www.garmin.com/unlock/update.jsp to see if an update for your map software is available.

You can also purchase additional map data from Garmin and load the maps to the internal memory or an optional SD card.

Refer to the MapSource Help file for more information about using MapSource and loading maps and waypoints on your zūmo.

Optional Accessories

For more information about optional accessories, go to www.garmin.com/products/zumo400 or www.garmin.com/products/zumo450, and click the **Accessories** link. You can also contact your Garmin dealer to purchase accessories. Optional accessories include:

- Automotive mount
- Traffic receiver
- External remote antenna
- AC adapter
- Extras (see [pages 41–43](#))

Connecting Accessories to Your zūmo

Some Garmin traffic receivers must be plugged into a mini-USB port on the zūmo mount. The audio jacks are located on the left side of the zūmo mount.

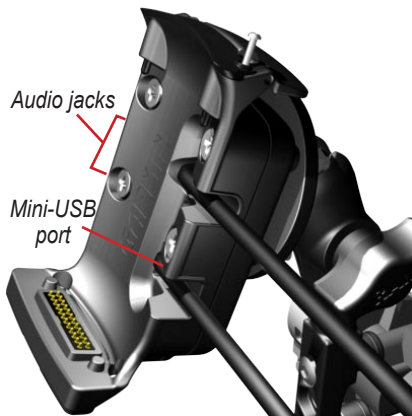



TIP: Carefully connect and disconnect cables. To disconnect, do not pull on the cable (cord), pull on the plug.

Garmin Travel Guide™

Much like a paper travel guide, the Garmin Travel Guide provides detailed information about locations, such as restaurants and hotels. To purchase the Travel Guide accessory, go to www.garmin.com/extras.

To use the Travel Guide:

1. Insert the SD card into your zūmo.
2. Touch  **Where to** >  **Extras**.
3. Touch the Travel Guide.
4. Touch a category. Touch a sub-category, if necessary.
5. Touch a location in the list.
6. Do one of the following:
 - Touch **Go** to go to the location.
 - Touch **Map** to view this item on the map.
 - Touch **Save** to save this location to your Favorites.
 - Touch **More** to view more information about the location.

Safety Cameras

Safety camera information is available in some locations. (Check <http://my.garmin.com> for availability.) For these locations, your zūmo includes the locations of hundreds of safety cameras. Your zūmo alerts you when you are approaching a safety camera and can warn you if you are driving too fast. The data is updated at least weekly, so you always have access to the most up-to-date information.

To get updated safety camera information:

1. Go to <http://my.garmin.com>.
2. Sign up for a subscription.

You can purchase a new region at any time, and you can extend existing subscriptions at any time. Each region that you purchase has its own expiration date.



Custom POIs (Points of Interest)

Load custom points of interest (POIs) onto your zūmo. POI databases are available from various companies on the Internet. Some custom databases contain alert information for points, such as school zones. A warning appears if you are traveling too fast near these custom POIs.

Use the Garmin POI Loader to load POIs on your Garmin drive or SD card. Download the POI Loader from www.garmin.com/extras.

Refer to the POI Loader Help file for more information; press F1 to open the Help file.

To view your custom POIs, touch  **Where to** >  **Extras** > **Custom POIs**.

To turn on or off custom POIs, touch  >  **Proximity Points** > **Proximity Alerts**.

To delete the custom POIs from your zūmo, connect your zūmo to your computer. Open the **Garminpoi** folder in the Garmin or SD card drive. Delete the file entitled **poi.gpi**.





CAUTION: Garmin is not responsible for the consequences of using a custom POI database or the accuracy of the safety camera or other custom POI database.

Garmin TourGuide™

The Garmin TourGuide allows your zūmo to play third-party, GPS-guided audio tours. These audio tours can take you on a route while playing interesting facts about historical sites along the way. As you travel, the audio information is triggered by GPS signals. For more information, go to www.garmin.com/extras and click **POI Loader**.

To view your Garmin TourGuide files, touch  **Where to** >  **Extras** > **Custom POIs**.

To change the Garmin TourGuide settings, touch  >  **Proximity Points** > **TourGuide**. Select **Auto Play** to hear the complete tour as programmed, **Prompted** to show the speaker icon  on the map when tour information is available during your route, or **Off**.

SaversGuide®

The SaversGuide is an optional accessory that is available only in North America (www.garmin.com/extras). With the SaversGuide preprogrammed SD data card and membership card, your zūmo is a digital coupon book that notifies you of merchants near your current location where you are eligible for a discount, such as restaurants, hotels, and movie theaters.

Battery Information







NOTE: See the *Important Safety and Product Information* guide for battery warnings.

Your zūmo contains an internal lithium-ion battery. The battery lasts up to 4 hours, depending on usage.

The  battery icon on the Menu page indicates the status of the internal battery. If the icon is not present, your zūmo is connected to external power. For information about charging your zūmo, see [page 37](#).

Maximizing the Battery Life

- Turn off GPS ( >  **System** > **GPS Mode** > **GPS Off**) when you do not need to receive GPS signals, or use **Normal** mode when WAAS or EGNOS is not available.
- Turn the backlight brightness down. Press and hold , and then use  and  to adjust the brightness.

- Do not leave your zūmo in direct sunlight. Avoid prolonged exposure to excessive heat or cold.

Replacing the Battery

To purchase a replacement lithium-ion battery pack, go to www.garmin.com/products/zumo400 or www.garmin.com/products/zumo450, and click the **Accessories** link.

Unscrew the battery pack and replace the battery. Contact your local waste disposal department for information on properly disposing of the battery.





Using a Remote Antenna

You can use an optional external remote antenna (Garmin GA 25MCX). To purchase, go to www.garmin.com/products/zumo400 or www.garmin.com/products/zumo450, and click the **Accessories** link.

Pull back the weather cap from the MCX connector located on the back of the zūmo, and connect the antenna.

About GPS Satellite Signals

Your zūmo must acquire GPS (Global Positioning System) satellite signals to operate. If you are indoors, near tall buildings or trees, or in a parking garage, your zūmo cannot acquire satellites. Go outside to an area free from tall obstructions to use your zūmo.

When your zūmo has acquired satellite signals, the signal strength bars on the Menu page are green . When it loses satellite signals, the bars turn red or disappear .

For more information about GPS, go to www.garmin.com/aboutGPS.

Specifications

Physical size: 4.4" W x 3.2" H x 2.87" D (11.3 x 8.2 x 7.2 cm)

Weight: 0.59 pounds (269 g)

Display: 2.8" W x 2.1" H (7.2 x 5.4 cm); 320 x 240 pixels; bright, 16-bit LCD, with white backlight and touch screen

Case: IPX7 waterproof

Temperature range: 32°F to 140°F (0°C to 60°C)

Data storage: Internal memory and optional removable SD card. Data stored indefinitely.

Computer interface: USB mass storage, plug-and-play

Charge time: Approximately 6 hours

Power input: 12 VDC

Usage: 15 W max. @ 13.8 VDC

Battery life: up to 4 hours depending on usage

GPS Performance Specifications

Receiver: WAAS enabled

Acquisition times*:

Warm: < 1 sec

Cold: < 38 sec

Factory Reset: < 45 sec

*On average for a stationary receiver with a clear view of the sky

Update rate: 1/sec, continuous

GPS accuracy:

Position: < 10 meters, typical

Velocity: 0.05 meter/sec RMS



GPS (WAAS) accuracy:

Position: < 5 meters, typical

Velocity: 0.05 meter/sec RMS

For a complete list of specifications, go to www.garmin.com/products/zumo400 or www.garmin.com/products/zumo450, and click **Specifications**.

zūmo Troubleshooting

Problem/Question	Solution/Answer
My battery gauge does not seem accurate.	Allow the unit to fully discharge and then fully charge it (without interrupting the charge cycle).
The touch screen is not responding to my taps properly.	Calibrate the touch screen . Turn the unit off. Press and hold  for about one minute until the Calibration screen appears. Follow the on-screen instructions.
The zūmo freezes up.	Reset the zūmo. Press and hold  and press  .
How do I clean the zumo?	The zūmo is constructed of high-quality materials and does not require user maintenance other than cleaning. Clean the unit's outer casing (not the touch screen) using a cloth dampened with a mild detergent solution, and then wipe dry. Avoid chemical cleaners and solvents that can damage plastic components.
How do I clean the touch screen?	Clean the touch screen with a soft, clean, lint-free cloth. Use water, isopropyl alcohol, or eyeglass cleaner, if needed. Apply the liquid to the cloth, and then gently wipe the touch screen.
The suction cup will not stay on my windshield.	Clean the suction cup and windshield with rubbing alcohol. Dry with a clean, dry cloth. Mount the suction cup as described on page 37 .

USB Interface Troubleshooting

Problem/Question	Solution/Answer
<p>How do I know my zūmo is in USB Mass Storage Mode?</p>	<p>When your zūmo is in USB Mass Storage Mode, a picture of a zūmo connected to a computer is shown. Also, you should see a new removable disk drive listed in My Computer (Windows) or a new volume (drive) on your desktop (Mac).</p>
<p>My computer never senses that the zūmo is connected.</p>	<ol style="list-style-type: none"> 1. Unplug the USB cable from your computer. 2. Turn the zūmo off. 3. Plug the USB cable into your computer and your zūmo. The zūmo automatically turns on and goes into USB Mass Storage Mode.
<p>I cannot find any drives named "Garmin" in my list of drives.</p>	<p>If you have several network drives mapped on your computer, Windows may have trouble assigning drive letters to your Garmin or SD drives. Follow the steps on the next page to assign (map) your drive letters.</p>
<p>I get a message saying "Unsafe Removal of Device" when I unplug the USB cable.</p>	<p>Windows: Double-click the Unplug or Eject  icon in your system tray. Select USB Mass Storage Device and click Stop. Select the Garmin drive and click OK. You can unplug your zūmo now.</p> <p>Mac: Drag the volume icon to the Trash. The Trash icon changes to an Eject icon. You can unplug your zūmo now.</p>

Problem/Question	Solution/Answer
How can I rename my Garmin drives in Windows?	<ol style="list-style-type: none">1. Open My Computer.2. Select the drive you want to rename.3. Right-click your mouse, and select Rename.4. Type the new name, and press the Enter key on your computer's keyboard.
How do I assign (map) my Garmin drives in Windows?	<ol style="list-style-type: none">1. Turn off your zūmo.2. Plug the USB cable into the zūmo and your computer. Your zūmo automatically turns on.3. Click Start > Settings > Control Panel > Administrative Tools > Computer Management > Storage > Disk Management.4. Click a zūmo removable disk drive (either the internal memory or your SD card drive). Right-click your mouse, and select Change Drive Letter and Path.5. Select Edit, select a drive letter from the drop-down list, and click OK.

INDEX

Symbols

2-D, 3-D map view 30

A

About button 31

accessories 40

address 11

add a stop 9

alerts, safety camera 42

antennas 40, 45

anti-theft feature 10, 31

audio

jacks 3, 38, 41

options 37

version 31

automotive mount 37

avoiding

road types 34

traffic 34

B

battery 44, 46

better route 10

brightness 2, 35

browsing the map 18

C

calibrating the touch screen 47

caring for your zūmo iv

car installation 37

charging the zūmo 37

cleaning 47

clearing user data 36

Compass page 34

computer connection 25

contact Garmin i

coordinates 19

current location, saving 15

customizing your zūmo 30–36

Custom POIs 42

D

dashboard mount 38

data storage drives 25, 46

daylight saving 32

Declaration of Conformity iv

deleting

all user data 36

character 13

custom POIs 43

Favorites 16, 17

files 27

detail maps 30

detours 10

diacritical characters 13

display settings 35

drives, Garmin 26

driving directions 22

E

editing saved places 15

EGNOS 31

ejecting the USB 27

expanding your search 19

Extras 41–42

F

Favorites 14

editing 15

finding 15

saving 14

sharing 14

FCC compliance iv

files

deleting 27

managing 25, 33

supported types 27

transferring 25–27

finding places

by address 11

by coordinates 19

by name 13

by postal code 11

intersection 11

item on the map 18

near another location 19

saved places (Favorites) 15

FM traffic 24

fuel gauge 21

G

Garmin Lock iv, 10, 31

Garmin TourGuide

playing files 43

Garmin Travel Guide 41

going home 12–19

Google Earth i

Go page 12

GPS 7, 45

H

home location 12

I

importing data 33

intersection 11

K

keyboard 13, 35

kilometers 32

L

languages 32

loading additional maps 40

locking your zūmo 10

M

M3U playlist 29

managing files 25–27

map

 browse 18

 customize 30

 Map Info button 30

 moving 18

 update maps 39

 using the Map page 18, 20

 version 30

 view 18, 30

 zoom 18

MapSource i, 25, 40

menu page 7

miles 32

mini-USB. *See* USB

motorcycle installation 3

mounting the zūmo

 in a car 38

 on a motorcycle 3

MP3 files

 loading 25

 playing 28

myGarmin i, 40, 42

N

navigation settings 34

Near button 19

Next Turn page 22

North Up map view 30

O

off road, routing 17, 34

P

picture viewer 33

PIN

 Garmin Lock 10

playing music 28

playlist 29

POIs, custom 42

position icon 20, 30

postal code 11

protecting your zūmo iv

R

recently found location 14

registering your zūmo 40

remote antenna 45

removable disk drive 26

removing the mount 39

resetting

 the max speed 21

 the trip data 21

 your zūmo 47

restoring settings 36

routes 16–18

routing preferences 34

S

safety cameras 42

Safe Mode 31

satellite signals 7, 45

SaversGuide 43

saving

 places you find 12, 14

 routes 16

 your current location 15, 18

school zone database 42

Screen Shot mode 35

SD card 1, 25, 46

 sharing 14, 17

security location 10

settings 30–36

setting your location 12, 18

sharing

 Favorites 14

 pictures 33

 routes 17

show map 12, 22

slide show 34

software
 updating 39
 version 31
special characters 13
specifications 46
spelling the name of a place 13
splash screen 35
storing your zūmo iv
supported file types 25
system settings 31

T

text language 32
time format 32
time zone 32
tones 34
touch screen
 aligning 47
 cleaning 47
Track Up map view 30
traffic
 avoiding 23, 34
 incidents 23
 settings 36
 subscriptions 24
transferring files 25–27
Trip Information page 21
trip log 33
troubleshooting 47–49
turn-by-turn directions 22
Turn List page 22

U

unit ID 31
updating
 maps 40
 zūmo software 39
USB
 mass storage mode 25–27
 ports 1, 25, 38, 39, 41
 troubleshooting 47
user data 33

V

vehicle icon 20, 30
vehicle type 34
view pictures 33
voice language 32
volume 2

W

WAAS 31
weather cap iv
WebUpdater 39

Z

zoom 18, 20, 33

**For the latest free software updates (excluding map data)
throughout the life of your Garmin products, visit the Garmin
Web site at www.garmin.com.**



© 2006–2007 Garmin Ltd. or its subsidiaries

Garmin International, Inc.

1200 East 151st Street, Olathe, Kansas 66062, USA

Garmin (Europe) Ltd.

Liberty House Hounslow Business Park, Southampton, Hampshire, SO40 9RB UK

Garmin Corporation

No. 68, Jangshu 2nd Road, Shijr, Taipei County, Taiwan

www.garmin.com

Part Number 190-00778-00 Rev. C

