



## VHF 300 Series Radio Installation Instructions

These installation instructions are for the following VHF radios and handsets:

North American Models	International Models
VHF 300	VHF 300i
VHF 300 AIS	VHF 300i AIS
GHS™ 10	GHS 10i

Throughout these instructions, both the VHF 300 and the VHF 300i will be referred to as the VHF 300 series radio, or “the radio”. The GHS 10 and the GHS 10i will be referred to as the GHS 10.

Compare the contents of this package with the packing list on the box. If any pieces are missing, contact your Garmin® dealer immediately.

### Product Registration

Help us better support you by completing our online registration today. Go to <http://my.garmin.com>. Keep the original sales receipt, or a photocopy, in a safe place.

### Contact Garmin

Contact Garmin Product Support if you have any questions while using your VHF 300 series radio. In the USA, go to [www.garmin.com/support](http://www.garmin.com/support), or contact Garmin USA by phone at (913) 397.8200 or (800) 800.1020.

In the UK, contact Garmin (Europe) Ltd. by phone at 0808 2380000.







In Europe, go to [www.garmin.com/support](http://www.garmin.com/support) and click **Contact Support** for in-country support information, or contact Garmin (Europe) Ltd. by phone at +44 (0) 870.8501241.

### Warnings and Safety Notices

#### Antenna Mounting and EME Exposure

The VHF 300 series radio generates and radiates radio frequency (RF) electromagnetic energy (EME). Failure to observe these guidelines may expose persons to RF radiation absorption exceeding the maximum permissible exposure (MPE).

Garmin declares an MPE radius of 59 in. (1.5 m) for this system, which was determined using 25 watts output to an omni-directional 9 dBi gain antenna. The antenna should be installed such that a distance of 59 in. (1.5 m) is maintained between the antenna and all persons.

- 
-  **WARNING:** Radio operators with cardiac pacemakers, life-support machines, or electrical medical equipment should not be exposed to excessive radio-frequency fields.
- 
-  **WARNING:** Operate the device in accordance with the instructions supplied.
- 
-  **CAUTION:** Wear safety goggles and a dust mask when drilling, cutting, or sanding.
- 
-  **NOTICE:** The device complies with internationally recognized standards covering human exposure to electromagnetic fields from radio devices.
- 
-  **NOTICE:** Check with local authorities for any antenna or operational restrictions that may apply.
- 
-  **NOTICE:** To prevent possible damage to your radio, the antenna must be connected to the radio before transmitting. This ensures that the power output to the antenna port dissipates properly when transmitting.
- 

### Needed Tools

- Drill and drill bits
- #2 Phillips screwdriver
- 3 1/2 in. (90 mm) hole saw (for installing the active speaker)
- Waterproof, adhesive tape (such as rubber vulcanizing tape)

## Installing your VHF 300 Series Radio

1. Select locations for the radio components.
2. Install the transceiver box (page 3).
3. Install the active speaker (page 4).
4. Install the GHS 10 (page 5).

Although these options are not necessary to use your radio, these instructions cover the following additional installation options.

- Connecting the GHS 10 to a passive speaker (page 5)
- Connecting the radio to a chartplotter or another GPS device (page 5)
- Connecting the radio to a hailer horn (page 7).

## Selecting Locations for the VHF 300 Series Radio Components

Use the diagram to determine how to best organize the VHF 300 series radio components on your boat. Test to be sure the cables reach all components before permanently mounting any component.

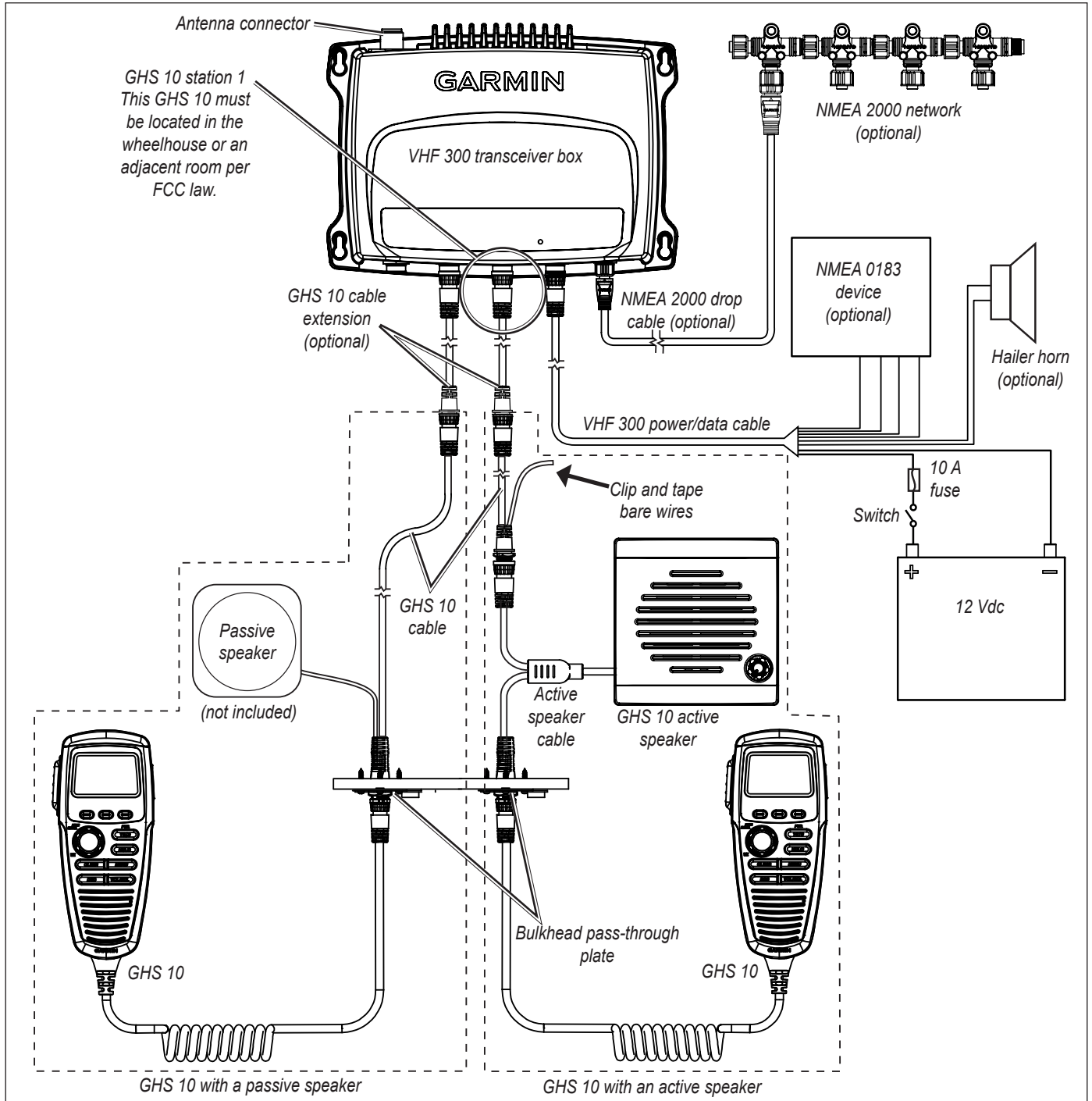

**VHF 300 Series Layout Diagram**

### Notes:

- Install the transceiver box in a dry, protected location.

- Connect the transceiver box to a 12 Vdc battery through an accessible switch.
- Install the GHS 10 connected to station one on the transceiver box in the wheelhouse or an adjacent room per Federal Communications Commission (FCC) law.
- Ensure that you install each component of the VHF radio at least 20 in. (.5 m) from any compass. Test your compass to verify that it operates correctly when the radio is operating.
- Extension cables are available for the GHS 10 cable.

## Installing the Transceiver Box

Install the transceiver box below deck on a bulkhead, in a location that is dry and protected from washdown. Ensure that the location is well ventilated and away from objects that generate heat. Ensure that the transceiver box is at least 20 in. (.5 m) from any compass to avoid interference.

## Mounting the Transceiver Box

1. Ensure that the chosen location is dry, protected, and well-ventilated.
2. Use the template on [page 11](#) to determine mounting holes.
3. Drill four 1/8 in. (3 mm) pilot holes.\*
4. Mount the transceiver box using the included M4.2×25 screws. You can also use bolts, washers, and nuts (not included) to mount the transceiver box if the mounting surface allows.

## Connecting the Transceiver Box to Power

Use the VHF 300 power/data cable to connect the transceiver box to a 12 Vdc battery through an external switch.

### Notes:

- Use the VHF 300 Power Wiring-Assignment Table to identify the positive and negative wires.
- The replacement fuse on the power/data wiring harness is a 10 A, slow-blow fuse.
- If it is necessary to extend the power wires, use at least 16 AWG wire.
- If your boat has an electrical system, you might be able to wire the radio directly to an unused holder on your fuse block. If you use the fuse block, remove the in-line fuse holder supplied with the power/data cable.

Device	Wire Color	Function
VHF 300 power/data cable	Red	Power—positive (+)
	Black	Ground—negative (-)

**VHF 300 Power Wiring-Assignment Table**

**NOTICE:** Cover the connections with a waterproof, adhesive tape, such as rubber vulcanizing tape, to prevent water from seeping into the radio.

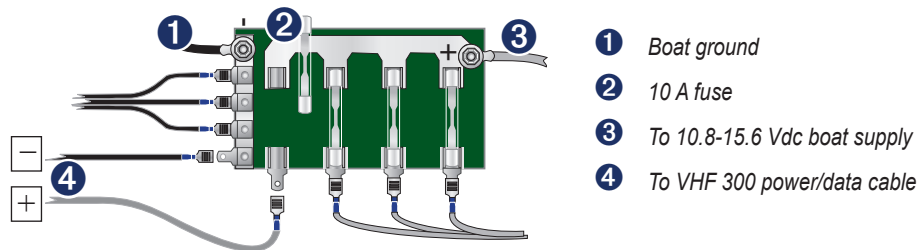

**Wiring the VHF 300 Through a Fuse Block**

## Connecting an Antenna to the Transceiver Box:

1. Mount the antenna on your boat according to the instructions provided by the antenna manufacturer.
2. Connect the antenna to the antenna port on the transceiver box.

**NOTE:** The antenna port is on the opposite side of the transceiver box from the primary row of connectors pictured on [page 4](#).

\* A 1/8 in. (3 mm) pilot hole is nominal for plywood. Different dashboard materials may require a different size pilot hole.

## Identifying the VHF 300 Transceiver Box Connectors

Use the illustration to identify the connectors on the VHF 300 transceiver box.

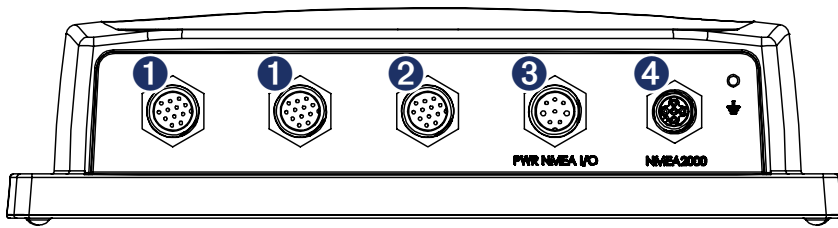

- 1 GHS 10 expansion connector
- 2 HS-1—primary GHS 10 connector the wheelhouse GHS 10 must connect to this port
- 3 VHF 300 power/data cable connector
- 4 NMEA 2000 connector (optional)  
Antenna port (on back - not pictured)

VHF 300 Transceiver Box Connectors

## Installing the GHS 10 and Speaker

The GHS 10 connects to the transceiver box and to either the Garmin GHS 10 active speaker (included) or a passive speaker (not included). When planning the GHS 10 installation, consider the following:

- Per FCC law, you must install the GHS 10 in the wheelhouse or an adjacent room.
- Install the GHS 10 and the active speaker at least 20 in. (.5 m) from any compass.
- Install the active speaker within 48 in. (1.2 m) of the location you mount the bulkhead pass-through plate.
- Consult the VHF 300 Series Layout Diagram on [page 2](#) to determine how to connect the GHS 10 through a bulkhead to a speaker and to the transceiver box.
- If the cable is not long enough to reach the GHS 10 mounting location from the transceiver box, extension cables are available in lengths of 16 ft. (5 m) and 32 ft. (10 m). Install any extensions between the GHS 10 cable and the transceiver box according to the layout diagram on [page 2](#).
- When you install the GHS 10 active speaker, if you use the GHS 10 cable to connect the active speaker to the transceiver box, do not connect a passive speaker to the GHS 10 cable. Clip and tape the passive speaker wires.

## Installing the GHS 10 Active Speaker

1. Use the GHS 10 active speaker Flush Mount Template to mount the active speaker. The template is self-adhesive.
2. Remove the paper backing from the template and adhere it to the bulkhead in a suitable location.
3. Use a 3 1/2 in. (90 mm) hole saw to cut the opening as indicated on the template.
4. Place the speaker in the cutout.
5. Ensure that the mounting screw locations align with the holes marked on the template. If they do not, mark the locations of new pilot holes.
6. Drill four 1/8 in. (3 mm) pilot holes\* in the correct location.
7. Use the included M4.2×25 screws to mount the active speaker.
8. Snap the cover plates on the active speaker.
9. To install the active speaker wiring harness to the transceiver box, use the GHS 10 cable according to the layout diagram on [page 2](#).

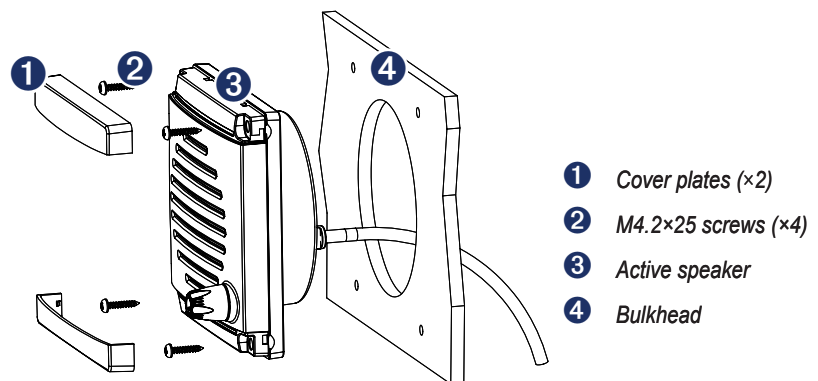

Mounting the Active Speaker

- Do not connect a passive speaker to the GHS 10 cable you use with the active speaker. Clip and tape the two passive speaker wires.
  - If the GHS 10 cable is not long enough to reach the transceiver box location, install an extension (not included) between the GHS 10 cable and the transceiver box as shown on the layout diagram on [page 2](#).
10. To install the active speaker wiring harness through the bulkhead, follow the procedures on [page 5](#).

\* A 1/8 in. (3 mm) pilot hole is nominal for plywood. Different dashboard materials may require a different size pilot hole.

## Installing a Passive Speaker (Optional)

1. Follow the mounting instructions provided by the manufacturer of your passive speaker if it is not already mounted.
2. Consult the manufacturer of your passive speaker to identify the positive and negative speaker wires or terminals.
3. Use the GHS 10 Cable Wiring-Assignment Table to identify the positive and negative wires.
4. Wire the correct positive and negative wires from the GHS 10 cable to the passive speaker.
5. Use at least 22 AWG wire for extended runs of wire, if needed.

Device	Wire Color	Function
GHS 10 cable	Yellow	Speaker positive (+)
	Green	Speaker negative (-)

**GHS 10 Cable Wiring-Assignment Table**

**NOTICE:** Cover the connections with a waterproof, adhesive tape, such as rubber vulcanizing tape, to prevent water from seeping into the radio.

## Installing the Bulkhead Pass-Through Plate

1. Route the GHS 10 active speaker cable (or the GHS 10 cable) to the location you want to install the bulkhead pass-through plate.
2. Drill a 1 in. (25 mm) hole in the location at which you want to pass through the bulkhead.
3. Place the bulkhead pass-through plate over the hole and mark the three pilot-hole locations.
4. Drill the three 1/8 in. (3 mm) pilot holes.\*
5. Connect the bulkhead pass-through plate to the bulkhead using the included M3.5 × 20 mm pan-head screws.
6. Remove the nut and connector cover from the GHS 10 cable (or the active speaker cable) and feed the connector through the bulkhead pass-through plate.
7. Place the GHS 10 connector cover over the connector.
8. Use the nut to fasten the connector to the bulkhead pass-through plate.

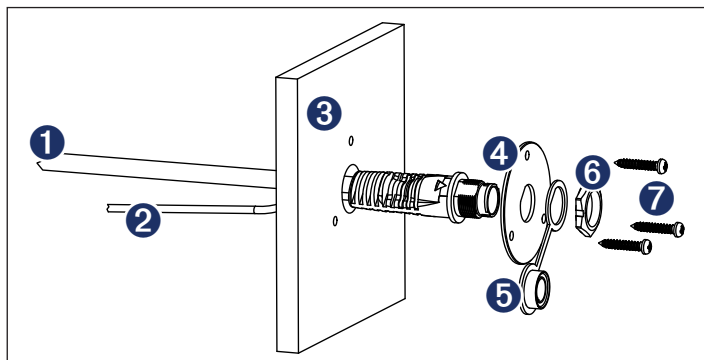

- 1 To the VHF 300 series transceiver box, or to the active speaker (cable dependent)
- 2 To a passive speaker (GHS 10 cable only)
- 3 Bulkhead
- 4 Bulkhead pass-through plate
- 5 GHS 10 connector cover
- 6 Nut
- 7 M3.5 × 20 mm screws

**Installing the Bulkhead Pass-Through Plate**

## Mounting the GHS 10 Hanger

Using the GHS 10 hanger as a template, mark and drill 1/8 in. (3 mm) pilot holes.\* Use three of the included 3.5 × 20 mm, panhead mounting screws to mount the hanger in a convenient location near the bulkhead pass-through plate.

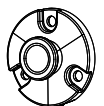

## Connecting the GHS 10

After you install the bulkhead pass-through plate and the GHS 10 hanger, connect the GHS 10 to the connector on the bulkhead pass through plate. Hang the GHS 10 on the GHS 10 hanger.

## Connecting the VHF 300 Series Radio to a Chartplotter (Optional)

You can connect the VHF 300 series radio to a chartplotter so that data such as DSC information can be displayed on the chartplotter. Additionally, the radio can use location information from the GPS function of the chartplotter for position reports, and so forth.

You can connect the VHF 300 series radio to a NMEA 2000 network to access a NMEA 2000-compatible GPS antenna or chartplotter, or you can wire the radio directly to a NMEA 0183-compliant chartplotter.

\* A 1/8 in. (3 mm) pilot hole is nominal for plywood. Different dashboard materials may require a different size pilot hole.

## Connecting the VHF 300 Series Radio to a NMEA 2000 Network

You can connect the VHF 300 series radio to your existing NMEA 2000 network, or you can build a basic NMEA 2000 network to connect to another NMEA 2000-compatible device, such as a chartplotter. For more information on NMEA 2000 and to purchase required connectors, go to [www.garmin.com](http://www.garmin.com).

### To connect the VHF 300 series radio to your existing NMEA 2000 network:

1. Determine where you would like to connect the radio to your existing NMEA 2000 backbone.
2. Disconnect one side of a NMEA 2000 T-connector from the backbone at an appropriate location.  
If you need to extend the NMEA 2000 backbone, connect an appropriate NMEA 2000 backbone extension cable to the side of the T-connector you disconnected.
3. Add a T-connector (not included) for the radio to the NMEA 2000 backbone by connecting it to the side of the T-connector you disconnected.
4. Route a NMEA 2000 drop cable (not included) to the bottom of the T-connector added in step 3 to your NMEA 2000 network. Use a drop cable with a length up to 20 ft. (6 m).
5. Connect the drop cable to the T-connector and the NMEA 2000 port on the VHF 300 Series transceiver box.

**NOTICE:** If you have an existing NMEA 2000 network on your boat, it should already be connected to power. Do not connect an additional NMEA 2000 power cable to an existing NMEA 2000 network, because only one power source should be connected to a NMEA 2000 network.

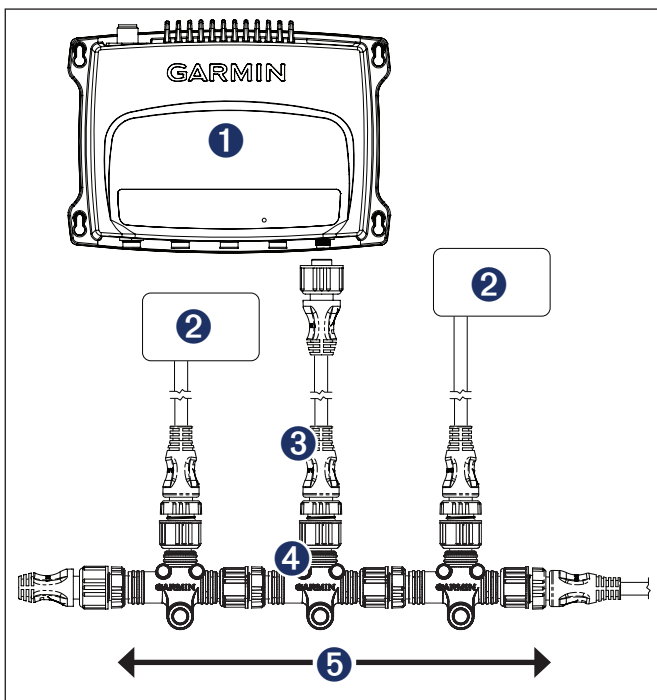

Connecting the VHF 300 Series Radio to an Existing NMEA 2000 Network

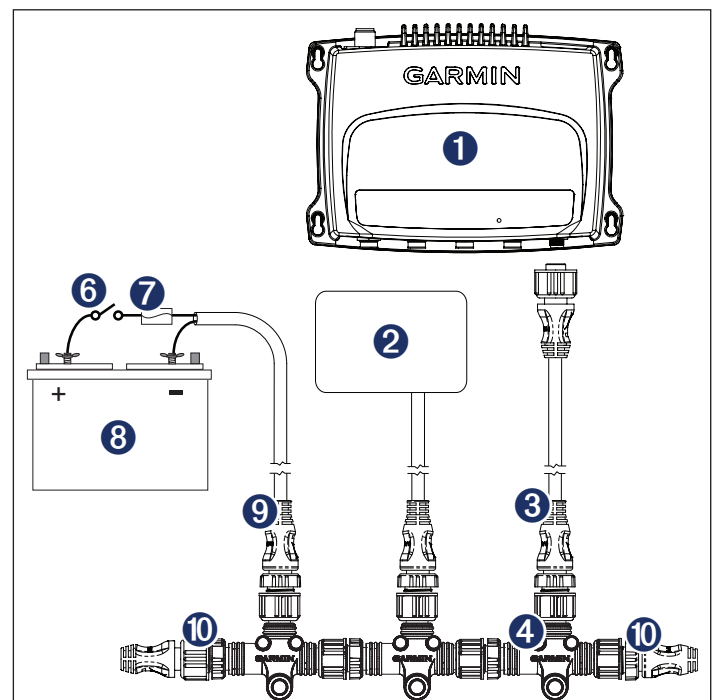

Creating a Basic NMEA 2000 Network

- |                                   |                              |  |
|-----------------------------------|------------------------------|--|
| 1 VHF 300 series transceiver box  | 5 Existing NMEA 2000 network | 9 NMEA 2000 power cable (not included) |
| 2 NMEA 2000 device (not included) | 6 Ignition or in-line switch | 10 Terminator (not included)           |
| 3 Drop cable (not included)       | 7 Fuse                       |  |
| 4 T-connector (not included)      | 8 12 Vdc battery             |  |

**To create a basic NMEA 2000 network:**

1. Connect two T-connectors (not included) together by their sides.
2. Connect a NMEA 2000 power cable (not included) to one of the T-connectors.

**NOTICE:** A NMEA 2000 power cable must be connected to a 12 Vdc power source through a switch. The NMEA 2000 network may drain your battery if it is connected directly. Connect the cable to the ignition switch of the boat if possible, or through an appropriate additional switch.

3. Connect a NMEA 2000 drop cable (not included) to the other T-connector and to the NMEA 2000 port on the VHF 300 Series transceiver box.
4. Add additional T-connectors for each device you add to the NMEA 2000 network, and connect each device to a T-connector with a drop cable.
5. Connect terminators (not included) to each end of the combined T-connectors.

**Connecting the VHF 300 Series to a NMEA 0183 Device**

The following diagram illustrates the NMEA 0183 wiring used to connect your VHF 300 series radio to a GPS chartplotter.

Connect NMEA 0183 bare wires as indicated in the following illustration. Use 22 AWG wire for extended runs of wire, if needed.

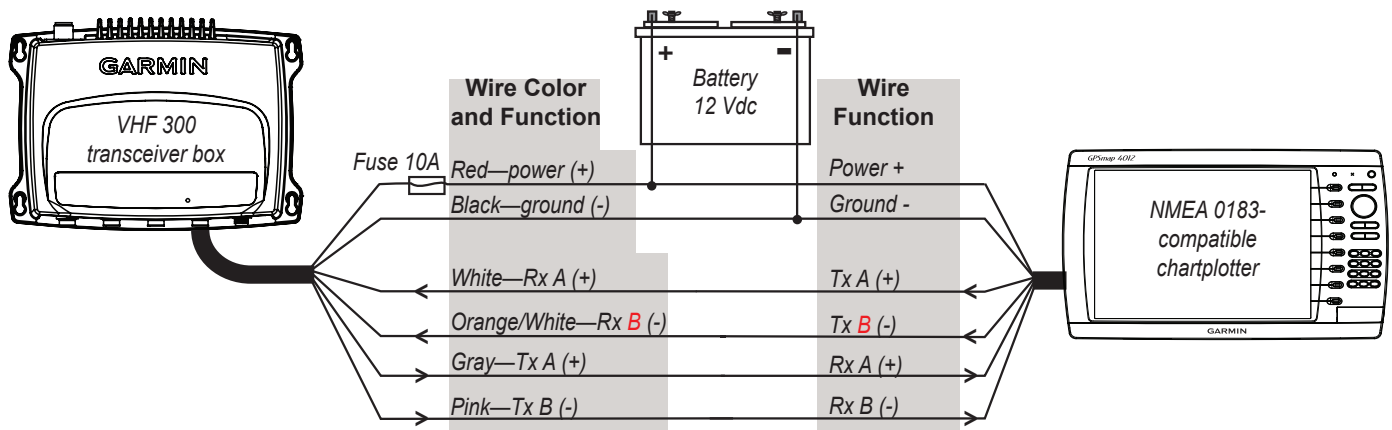

**Connecting a VHF 300 Series Radio to a NMEA 0183 Device**

**NOTICE:** Cover the connections with a waterproof, adhesive tape, such as rubber vulcanizing tape, to prevent water from seeping into the radio.

**Connecting the VHF 300 Series Radio to a Hailer Horn (Optional)**

1. Follow the mounting instructions provided by the manufacturer of your hailer horn if it is not already mounted.
2. Consult the manufacturer of your hailer horn to identify the positive and negative wires or terminals.
3. Use the VHF 300 Series Hailer-Horn Wiring Assignment Table to identify the positive and negative wires.
4. Wire the correct positive and negative wires from the VHF 300 power/data cable to the passive speaker.
5. Use 22 AWG wire for extended runs of wire, if needed.

Cable	Wire Color	Function
VHF 300 power/ data cable	Yellow	Hailer-horn positive (+)
	Green	Hailer-horn negative (-)

**VHF 300 Series Hailer-Horn Wiring-Assignment Table**

**NOTICE:** Cover the connections with a waterproof, adhesive tape, such as rubber vulcanizing tape, to prevent water from seeping into the radio.

# Appendix

## Specifications

### Transceiver Box

**Dimensions:** W × H × D:  $9 \frac{3}{4} \times 7 \frac{3}{32} \times 2 \frac{1}{2}$  in. (248 × 180 × 64 mm)

**Weight:** 4.177 lb. (1.895 kg)

**Temperature Range:** from 14°F to 122°F (from -10°C to 50°C)

**Compass-safe Distance:** 20 in. (.5 m)

**Waterproof Rating:** IEC 60529 IPX7 (Immersion in 1 meter of standing water for 30 minutes)

**Operating Voltage:** 10.8–15.6 Vdc (12 Vdc boat battery)

**Current Drain:** 2 A max–6 A max (low power–high power transmit)

**Antenna Connector:** S0-239 (50 Ω)

**Max Antenna Gain:** 9 dBi

**Antenna Port Impedance:** 50 Ω

### GHS 10

**Dimensions:** W × H × D:  $6 \frac{11}{32} \times 2 \frac{13}{16} \times 1 \frac{11}{16}$  in. (161 × 71.6 × 42.8 mm)

**Weight:** 12.98 oz. (368 g)

**Temperature Range:** from 14°F to 122°F (from -10°C to 50°C)

**Compass-safe Distance:** 20 in. (.5 m)

**Waterproof Rating:** IEC 60529 IPX7 (Immersion in 1 meter of standing water for 30 minutes)

### Active Speaker

**Dimensions:** W × H × D:  $4 \frac{5}{16} \times 4 \frac{3}{8} \times 2 \frac{1}{2}$  in. (109.7 × 111.4 × 63.5 mm)

**Weight:** 16.37 oz. (464 g)

**Temperature Range:** from 14°F to 122°F (from -10°C to 50°C)

**Compass-safe Distance:** 20 in. (.5 m)

**Waterproof Rating:** IEC 60529 IPX7 (Immersion in 1 meter of standing water for 30 minutes)

### Auxiliary Components

**Hailer Output Power:** 30 W max

**Hailer Horn Impedance:** 4 Ω

**Passive Speaker Output Power:** 4 W (4 Ω max)

**Passive Speaker Impedance:** 4 Ω

### Cables

**Power/data Cable:** 78 in. (2 m)

**GHS 10 cable:** 32 ft. (10 m)

**Active speaker cable (attached to the active speaker):** 59 in. (1.5 m)



## Communications

### NMEA 2000

Use this table to determine the approved NMEA 2000 PGN information that can be received and transmitted by a VHF 300 series radio when communicating with a NMEA 0183-compliant device.

Receive		Transmit	
059392	ISO Acknowledgment	059392	ISO Acknowledgment
059904	ISO Request	060928	ISO Address Claim
060928	ISO Address Claim	126208	NMEA Request/Command/Acknowledge Group Function
126208	NMEA - Command/Request/Acknowledge Group Function	126464	PGN List
129026	COG (course over ground) and SOG (speed over ground) - Rapid Update	126996	Product Information
129029	GNSS (Global Navigation Satellite System) Position Data	129038*	AIS Class A Position Report
129039*	AIS Class B Position Report	129040*	AIS Class B Extended Position Report
129794*	AIS Class A Static and Voyage Related Data	129798*	AIS SAR Aircraft Position Report
129808	DSC Call Information	129799	Radio Frequency/Mode/Power
		129799	Radio Frequency/Mode/Power
		129808	DSC Call Information



Garmin VHF 300 Series radios are NMEA 2000 certified.

### NMEA 0183

The VHF 300 series radio can receive and transmit the following NMEA 0183 sentences (version 3.01) from a NMEA 0183-compliant device:

Sentence (Receive)	Definition	Sentence (Transmit)	Definition
GGA	Global Positioning System Fix Data	DSC	DSC Information
GLL	Geographic Position (Latitude and Longitude)	DSE	Expanded DSC
GNS	GNSS (Global Navigation Satellite System) Fix Data	VDM*	AIS Information
RMA	Recommended Minimum Specific Loran-C Data		
RMB	Recommended Minimum Navigation Information		
RMC	Recommended Minimum Specific GNSS Data		

Refer to the *VHF 300 Series Owner's Manual* to operate the GHS 10 or GHS 10i handset.

The CE Notified Body number (0168) is valid for the VHF 300i and VHF 300i AIS only.

**CE 0168**

\* VHF 300 AIS models only

Garmin International, Inc.  
1200 East 151<sup>st</sup> Street,  
Olathe, Kansas 66062, USA  
Tel. (913) 397.8200 or (800) 800.1020  
Fax (913) 397.8282

Garmin (Europe) Ltd.  
Liberty House  
Hounslow Business Park,  
Southampton, Hampshire, SO40 9LR UK  
Tel. +44 (0) 870.8501241 (outside the UK)  
0808 2380000 (within the UK)  
Fax +44 (0) 870.8501251

Garmin Corporation  
No. 68, Jangshu 2<sup>nd</sup> Road,  
Sijhih, Taipei County, Taiwan  
Tel. 886/2.2642.9199  
Fax 886/2.2642.9099

All rights reserved. Except as expressly provided herein, no part of this manual may be reproduced, copied, transmitted, disseminated, downloaded or stored in any storage medium, for any purpose without the express prior written consent of Garmin. Garmin hereby grants permission to download a single copy of this manual onto a hard drive or other electronic storage medium to be viewed and to print one copy of this manual or of any revision hereto, provided that such electronic or printed copy of this manual must contain the complete text of this copyright notice and provided further that any unauthorized commercial distribution of this manual or any revision hereto is strictly prohibited.

Information in this document is subject to change without notice. Garmin reserves the right to change or improve its products and to make changes in the content without obligation to notify any person or organization of such changes or improvements. Visit the Garmin Web site ([www.garmin.com](http://www.garmin.com)) for current updates and supplemental information concerning the use and operation of this and other Garmin products.

Garmin® and the Garmin logo are trademarks of Garmin Ltd. or its subsidiaries, registered in the USA and other countries. GHS™ is a trademark of Garmin Ltd. or its subsidiaries. These trademarks may not be used without the express permission of Garmin.

NMEA 2000® and the NMEA 2000 logo are registered trademarks of the National Maritime Electronics Association.

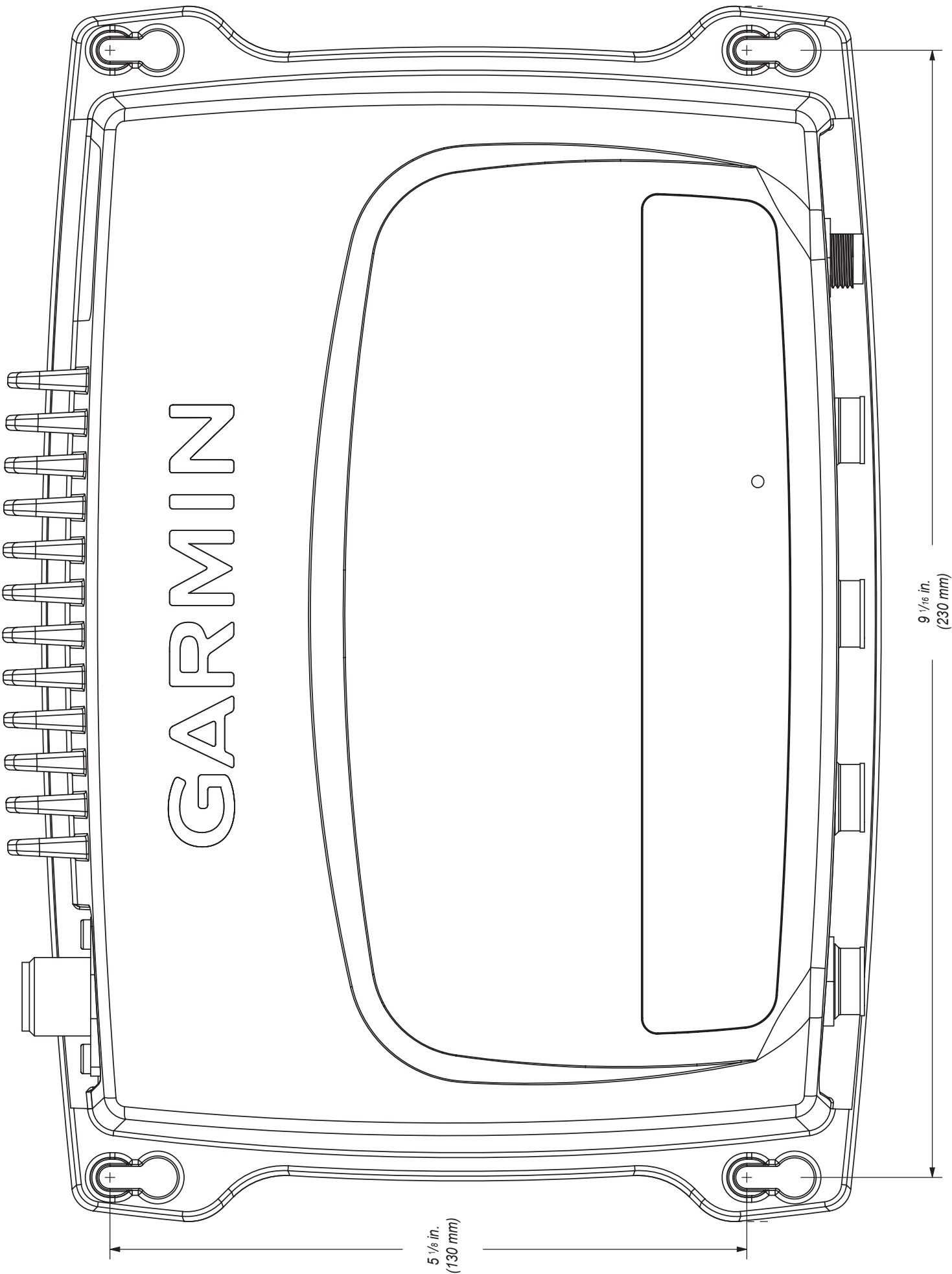

GARMIN

5 1/8 in.  
(130 mm)

9 1/16 in.  
(230 mm)

**For the latest free software updates (excluding map data) throughout the life of your  
Garmin products, visit the Garmin Web site at [www.garmin.com](http://www.garmin.com).**



© 2010 Garmin Ltd. or its subsidiaries

Garmin International, Inc.  
1200 East 151<sup>st</sup> Street, Olathe, Kansas 66062, USA

Garmin (Europe) Ltd.  
Liberty House, Hounsdown Business Park, Southampton, Hampshire, SO40 9LR UK

Garmin Corporation  
No. 68, Jangshu 2<sup>nd</sup> Road, Shijr, Taipei County, Taiwan

[www.garmin.com](http://www.garmin.com)