

GPS 19x HVS TECHNICAL SPECIFICATIONS



GARMIN®

190-01361-07_0C

January 2024

© 2012–2024 Garmin Ltd. or its subsidiaries

All rights reserved. Under the copyright laws, this manual may not be copied, in whole or in part, without the written consent of Garmin. Garmin reserves the right to change or improve its products and to make changes in the content of this manual without obligation to notify any person or organization of such changes or improvements. Go to www.garmin.com for current updates and supplemental information concerning the use of this product.

Garmin® and MapSource® are registered trademarks of Garmin Ltd. or its subsidiaries and may not be used without the express permission of Garmin.

Windows® is a registered trademark of the Microsoft Corporation.

Macintosh® is a registered trademark of Apple Inc.

support.garmin.com

TABLE OF CONTENTS

1	Introduction	5
1.1	Caution	5
1.2	FCC Compliance	5
1.3	Limited Warranty	5
1.4	Overview	5
1.5	Features	6
1.6	GPS 19x Series	6
1.6.1	GPS 19x HVS	6
1.6.2	GPS 19x NMEA 2000	6
1.7	Technical Specifications	6
1.7.1	Physical Characteristics	6
1.7.1.1	Size	6
1.7.1.2	Weight	7
1.7.1.3	Color	7
1.7.1.4	Case Material	7
1.7.1.5	Cable Length	7
1.7.2	Electrical Characteristics	7
1.7.2.1	Input Voltage	7
1.7.2.2	Input Current	7
1.7.2.3	CMOS Serial Output Levels	7
1.7.2.4	GPS Receiver Sensitivity	7
1.7.2.5	Environmental Characteristics	7
1.7.3	GPS Performance	7
1.7.3.1	Receiver	7
1.7.3.2	Acquisition Times	7
1.7.3.3	Update Rate	7
1.7.3.4	Accuracy	7
1.7.4	Interfaces	7
1.7.4.1	GPS 19x HVS Electrical Characteristics	7
1.7.4.2	Garmin Interface	8
1.7.4.3	GPS 19x HVS Protocol	8
1.7.4.4	Measurement Pulse Output	8
2	Wiring and Pinouts	9
2.1	Pinout	9
2.2	Wiring Diagrams	9
3	Mechanical Characteristics & Mounting	12
4	GPS 19x HVS Software Interface	13
4.1	Received NMEA 0183 Sentences	13
4.1.1	Almanac Information (GPALM)	13
4.1.2	Sensor Initialization Information (PGRMI)	14
4.1.3	Sensor Configuration Information (PGRMC)	14
4.1.4	Additional Sensor Configuration Information (PGRMC1)	15
4.1.5	Additional Sensor Configuration Information 2 (PGRMC2)	15
4.1.6	Output Sentence Enable/Disable (PGRMO)	16
4.2	Transmitted NMEA 0183 Sentences	17
4.2.1	Sentence Transmission Rate	17
4.2.2	Transmitted Time	18
4.2.3	Global Positioning System Almanac Data (GPALM)	18
4.2.4	GLONASS System Almanac Data (GLMLA)	19

4.2.5	Global Positioning System Fix Data (GGA)	19
4.2.6	GPS DOP and Active Satellites (GSA)	19
4.2.7	GPS and GLONASS Satellites in View (GPGSV and GLGSV)	19
4.2.8	Recommended Minimum Specific GPS/TRANSIT Data (RMC)	20
4.2.9	Track Made Good and Ground Speed (VTG)	20
4.2.10	Geographic Position (GLL)	20
4.2.11	Estimated Error Information (PGRME)	21
4.2.12	GPS Fix Data Sentence (PGRMF)	21
4.2.13	Map Datum (PGRMM)	21
4.2.14	Sensor Status Information (PGRMT)	21
4.2.15	3D Velocity Information (PGRMV)	21
4.2.16	DPGS Beacon Information (PGRMB)	22
4.3	Baud Rate Selection	22
4.4	Measurement Pulse Output	22
4.4.1	One-Pulse-Per-Second (PPS) Output	22

Appendix A: Earth Datum List 23

Appendix B: Garmin Binary Output Format..... 26

Appendix C: Changing the Baud Rate in Garmin Mode..... 30

Appendix D: GPS 19x HVS AND Windows Serial Mouse Issue..... 31

Appendix E: Sensor Configuration Software..... 33

Downloading the Sensor Configuration Software	33
Selecting a Model	33
Connecting to the Sensor	33
Menus	33
File Menu	33
Comm Menu	33
Config Menu	34
View Menu	34
Help Menu	34

LIST OF TABLES AND FIGURES

Figure 1: Computer Serial Port Interconnection	9
Figure 2. PDA Serial Port Interconnection	10
Figure 3a. GPS 19x NMEA 0183 HVS Wired for Two-Way Communication	10
Figure 3b. GPS 19x NMEA 0183 HVS Power/Data Cable	11
Figure 4. GPS 19x HVS Bottom Case Dimensions	12
Table 2: NMEA 0183 Output Sentence Order and Size	17
Table 3: Characters per Second for Available Baud Rates	18

1 INTRODUCTION

1.1 CAUTION

The GPS system is operated by the government of the United States, which is solely responsible for its accuracy and maintenance. The GLONASS system is operated by the government of Russia, which is solely responsible for its accuracy and maintenance. Although the device is a precision electronic NAVigation AID (NAVAID), any NAVAID can be misused or misinterpreted, and therefore become unsafe. Use these products at your own risk. To reduce the risk, carefully review and understand all aspects of these Technical Specifications before using the device. When in actual use, carefully compare indications from the GPS to all available navigation sources including the information from other NAVAIDs, visual sightings, charts, etc. For safety, always resolve any discrepancies before continuing navigation.

1.2 FCC COMPLIANCE

This device complies with part 15 of the FCC Rules. Operation is subject to the following two conditions: (1) this device may not cause harmful interference, and (2) this device must accept any interference received, including interference that may cause undesired operation.

This equipment has been tested and found to comply with the limits for a Class B digital device, pursuant to part 15 of the FCC rules. These limits are designed to provide reasonable protection against harmful interference in a residential installation. This equipment generates, uses, and can radiate radio frequency energy and may cause harmful interference to radio communications if not installed and used in accordance with the instructions. However, there is no guarantee that interference will not occur in a particular installation. If this equipment does cause harmful interference to radio or television reception, which can be determined by turning the equipment off and on, the user is encouraged to try to correct the interference by one of the following measures:

- Reorient or relocate the receiving antenna.
- Increase the separation between the equipment and the receiver.
- Connect the equipment into an outlet on a circuit different from that to which the receiver is connected.
- Consult the dealer or an experienced radio/TV technician for help.

This product does not contain any user-serviceable parts. Repairs should only be made by an authorized Garmin service center. Unauthorized repairs or modifications could result in permanent damage to the equipment, and void your warranty and your authority to operate this device under Part 15 regulations.

1.3 LIMITED WARRANTY

The Garmin standard limited warranty applies to this device. For more information, go to garmin.com/support/warranty.

1.4 OVERVIEW

The GPS 19x HVS is an embedded receiver and an antenna. Based on the proven technology found in other Garmin GPS receivers, the GPS 19x HVS tracks multiple satellites at a time while providing fast time-to-first-fix, precise navigation updates from once per second up to ten times per second, and low power consumption. This generation of GPS sensors includes the capability of FAA Wide Area Augmentation System (WAAS) differential GPS. In addition to the GPS satellite system, the GPS 19x HVS also supports simultaneous use of the Russian GLONASS satellite system.

The GPS 19x HVS design uses the latest technology and high-level circuit integration to achieve superior performance while minimizing space and power requirements. The hardware capability combined with software intelligence makes the GPS 19x HVS easy to integrate and use.

The GPS 19x HVS is designed to withstand rugged operating conditions and is waterproof to IEC 60529 IPX7: immersion in 1 meter of water for 30 minutes. The complete GPS receiver requires minimal additional components to be supplied by an OEM or system integrator. A minimum system must provide the GPS receiver with a source of power and a clear view of the GPS satellites. Internal FLASH memory allows the GPS to retain critical data such as satellite orbital parameters, last-known position, date and time. End user interfaces such as keyboards and displays are the responsibility of the application designer.

Factory configuration meets the needs of most systems that expect NMEA 0183 data from a GPS receiver. GPS19x supports two out of the box factory configurations. One is backward compatible with GPS17x operating at positioning update rate of once per second and communicating at 4800bps. The

other is operating at positioning update rate of 10 times per second and communicating at 38400bps. The two configurations are selectable with a resistor accessory wire. Configuration commands are available to customize the operation mode and NMEA 0183 output (see [section 4.1 Received NMEA 0183 Sentences](#))

1.5 FEATURES

- GPS receiver tracks and uses multiple satellites for fast, accurate positioning and velocity estimates.
- Differential DGPS capability using real-time WAAS corrections (when WAAS is enabled) yielding position errors of less than 3 meters.
- GLONASS support. This receiver can also track and use multiple GLONASS satellites in addition to GPS satellites. This increases positioning reliability in many situations due to higher total number of visible satellites. GLONASS is the Russian system of navigation satellites, similar to the United States' GPS.
- 10Hz operation. Real position, heading and velocity updates of up to 10 times per second. Higher positioning update rates may result in more accurate positioning.
- Compact, rugged design ideal for applications with minimal space.
- Two update-rate configurations available: 10 times per second at 38400bps and 1 time per second at 4800bps.
- Highly accurate measurement pulse output for precise timing measurements: one-pulse-per-second (1 Hz). Pulse width is configurable in 20 millisecond increments from 20 ms to 980 ms with 1 μ s accuracy.
- Configurable for binary format data output.
- FLASH-based program allows new software revisions through a Web site download.
- Non-volatile memory does not require battery backup.
- Onboard rechargeable backup battery can maintain the real-time clock for up to 10 days.
- Configurable parameters include expected position, current time and date, and preferred position fix type (3D or automatic).
- Waterproof design allows continuous exposure to the prevailing weather conditions at most locations.

1.6 GPS 19X SERIES

There are two different versions of GPS 19x available. This document focuses on the HVS version.

1.6.1 GPS 19x HVS

The GPS 19x HVS interfaces to a RS-232 serial port of a computer via a DB-9 connector and receives power through a vehicle power adapter. The GPS 19x is RS-422 compatible. See the [wiring diagrams](#) for correct wiring.

The GPS 19x HVS can cause an issue with Microsoft® Windows® operating systems if the DB9 connector is plugged into the computer before the computer is fully running. The Windows operating system may interpret the serial connector on the GPS 19x HVS as a serial mouse. Please refer to [Appendix D: GPS 19x HVS & Window Serial Mouse Issue](#) for complete details.

1.6.2 GPS 19x NMEA 2000

The GPS 19x is also available with a NMEA 2000 interface. See <https://www.garmin.com/en-US/p/100702/pn/010-01010-10> for details.

1.7 TECHNICAL SPECIFICATIONS

The following specifications are for the GSP 19x HVS. Specifications are subject to change without notice.

1.7.1 Physical Characteristics

1.7.1.1 Size

- 3 ¹⁹/₃₂ in. (96.1 mm) in diameter and 1 ¹⁵/₁₆ in. (49.5 mm) in height

1.7.1.2 Weight

- 7.1 oz. (201 g)

1.7.1.3 Color

- White

1.7.1.4 Case Material

- Fully gasketed high-impact plastic alloy, waterproof to IEC 60529 IPX7 standards

1.7.1.5 Cable Length

- 30 ft. (9.14 m)

1.7.2 Electrical Characteristics

1.7.2.1 Input Voltage

- 8–33 Vdc

1.7.2.2 Input Current

- 40 mA @ 12 Vdc

1.7.2.3 CMOS Serial Output Levels

- 0 Vdc to 3.3 Vdc (Differential NMEA 0183 Serial, Compatible Polarity)

1.7.2.4 GPS Receiver Sensitivity

- -185 dBW minimum

1.7.2.5 Environmental Characteristics

- Operating Temperature: -22° to 176°F (-30° to 80°C)
- Storage Temperature: -40° to 194°F (-40° to 90°C)

1.7.3 GPS Performance

1.7.3.1 Receiver

WAAS enabled GPS receiver continuously tracks and uses multiple satellites to compute and update your position. The receiver can track and use GPS as well as GLONASS satellites at the same time. This will often exceed 20 satellites at the same time.

1.7.3.2 Acquisition Times

- Reacquisition: Less than 2 seconds
- Hot: Approx. 1 second (all data known)
- Warm: Approx. 38 seconds (initial position, time, and almanac known; ephemeris unknown)
- Cold: Approx. 45 seconds

1.7.3.3 Update Rate

- 1, 5, or 10 records per second

1.7.3.4 Accuracy

- GPS Standard Positioning Service (SPS)
Position: < 15 meters, 95% typical
Velocity: 0.1 knot RMS steady state
- WAAS/EGNOS/MSAS
Position: < 3 meters, 95% typical
Velocity: 0.1 knot RMS steady state
- Measurement Pulse Output Time: ±1 microsecond at rising edge of the pulse
- Dynamics: 999 knots velocity (only limited at altitude greater than 60,000 feet), 2g dynamics

1.7.4 Interfaces

1.7.4.1 GPS 19x HVS Electrical Characteristics

- Differential NMEA 0183 Serial, Compatible Polarity.
 - The default transmission rate is 38400 baud. If necessary, the rate can be limited to 4800 baud by installing the included resistor in series with the Accessory-ON wire. See the *GPS 19x NMEA 0183 Installation Instructions* for more information.

- The default position output rate is 10Hz. If necessary, the rate can be limited to 1Hz by installing the included resistor in series with the Accessory-ON wire. See the *GPS 19x NMEA 0183 Installation Instructions* for more information.

NOTE: When connecting this antenna to a GPSMAP 2000, 3000, 4000, or 5000 series device, you must limit the update rate. If the update rate is not limited, the chartplotter might not receive and display the GPS signal properly.

1.7.4.2 Garmin Interface

Refer to the *Garmin Device Interface Specification* found in the Garmin Device Interface SDK for information about the Garmin Interface. At the time of publication, this document is located on the Garmin Web site at: <https://www8.garmin.com/support/commProtocol.html>.

1.7.4.3 GPS 19x HVS Protocol

- NMEA 0183 Version 3.01 (the factory default version) is programmable by data field 7 of the PGRMC1 sentence described in [section 4.1.4 Additional Sensor Configuration Information \(PGRMC1\)](#).
- Available NMEA 0183 output sentences include GPALM, GPGGA, GPGSA, GPGSV, GPRMC, GPVTG, GPGLL, PGRME, PGRMF, PGRMM, PGRMT, PGRMV, and PGRMB (Garmin proprietary sentences). See [section 4.2 Transmitted NMEA 0183 Sentences](#) for format descriptions.
- Configuration and initialization is accomplished with NMEA 0183 input sentences. This allows initialization of information such as expected position, date, time, earth datum, and differential mode and configuration of operational parameters such as baud rate, positioning update rate, satellite system. See [section 4.1 Received NMEA 0183 Sentences](#) for format descriptions.
- Configurable for binary data output.

1.7.4.4 Measurement Pulse Output

- 1 Hz pulse with programmable width, configurable in 20 ms increments from 20 ms to 980 ms. See [section 4.1.3 Sensor Configuration Information \(PGRMC\)](#) for details about configuring the Measurement Pulse Output (or PPS) feature.
- 1 μ s accuracy for all conditions in which the GPS 19x HVS reported a valid and accurate position fix for at least the previous 4 seconds.

2 WIRING AND PINOUTS

GPS 19x HVS only

The GPS 19x HVS interfaces to a serial port. The unit accepts TIA-232-F (RS-232) level inputs and transmits voltage levels from ground 3.3 V, TIA-422 (RS-422) polarity.

2.1 PINOUT

GPS 19x HVS Pin #	Color	Signal Name	Wire Gauge
1	White	Receive Data A	22
2	Black	Ground	22
3	Red	VIN	22
4	Orange*	Accessory On*	22
5	White/Red	Transmit Data B	22
6	Gray	Transmit Data A	22
7	White/Orange	Receive Data B	22
8	Violet	Pulse Per Second (PPS)	22

* A resistor on the end of this wire limits the transmission rate to 4800 baud and the position update to 1Hz. Removing the resistor increases the baud rate to 38400 and the position update to 10Hz.

2.2 WIRING DIAGRAMS

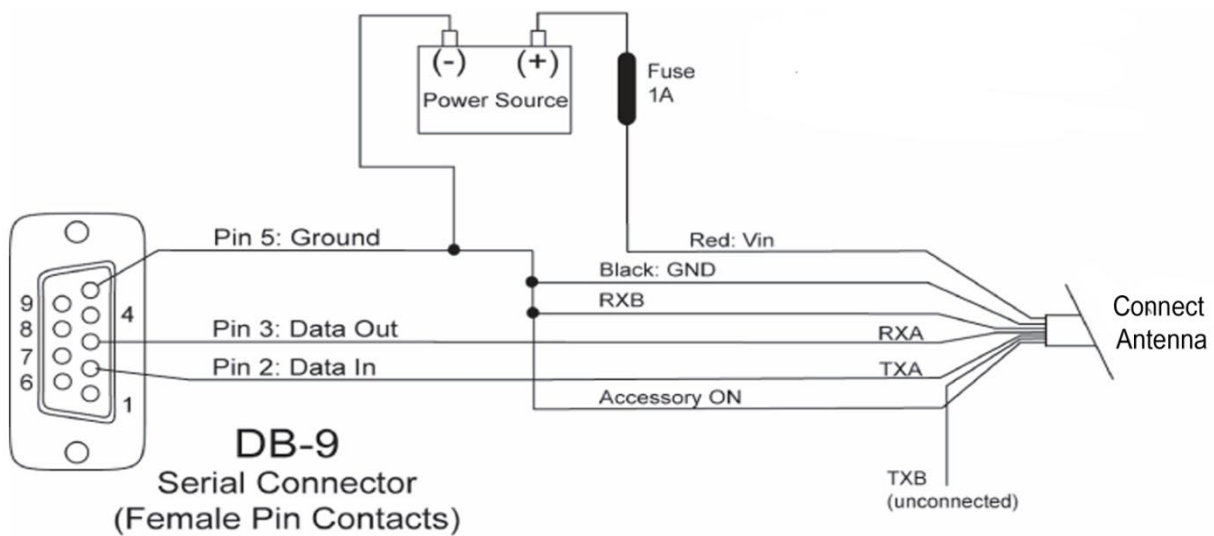

Figure 1: Computer Serial Port Interconnection

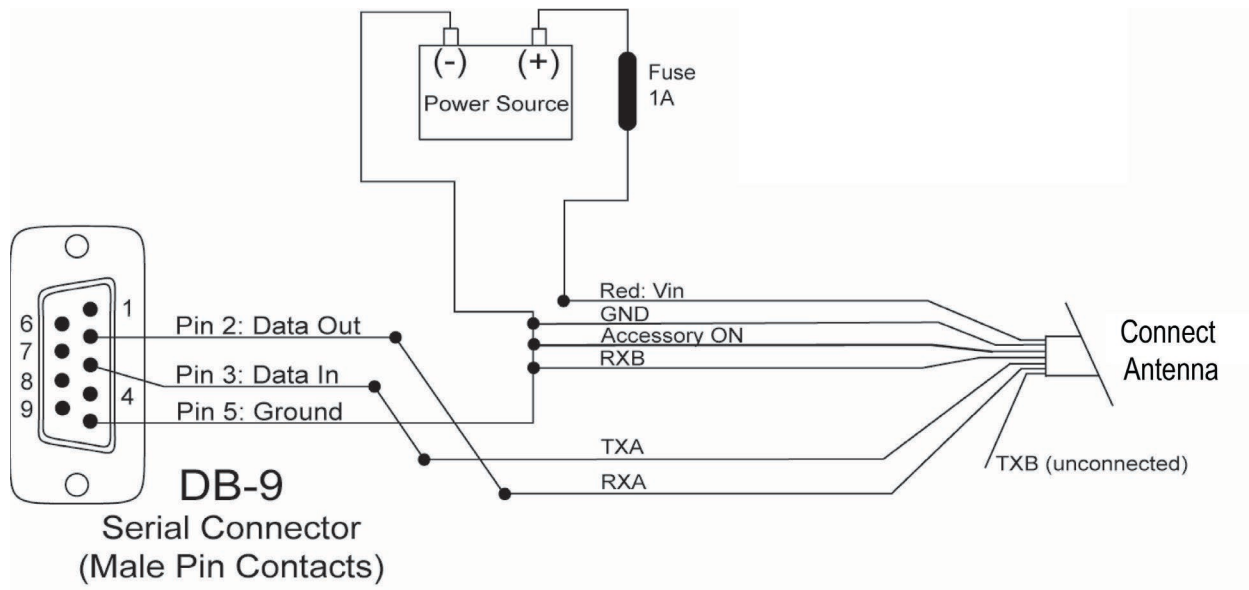

Figure 2. PDA Serial Port Interconnection

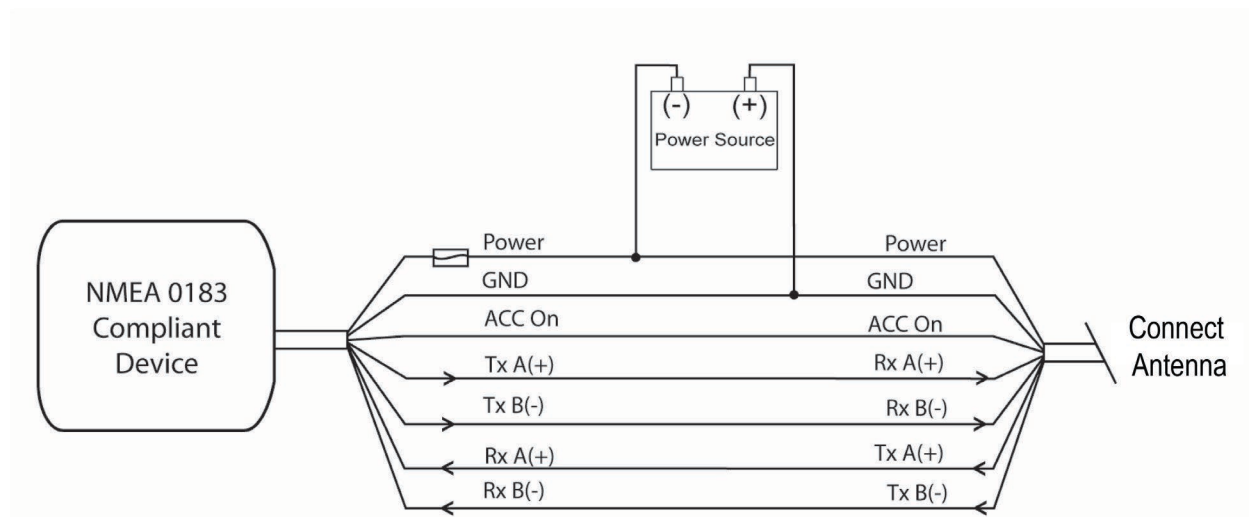

Figure 3a. GPS 19x NMEA 0183 HVS Wired for Two-Way Communication

Exceptions:

If your NMEA 0183-compliant device has only one receiving wire (Rx), connect it to the gray wire (Tx/A) from the GPS 19x antenna, and leave the white/red wire (Tx/B) from the antenna unconnected.

If your NMEA 0183-compliant device has only one transmitting wire (Tx), connect it to the white wire (Rx/A) from the GPS 19x antenna, and connect the white/orange wire (Rx/B) to ground.

Note: The orange (accessory on) wire is used when wiring the GPS 19x to a Garmin chartplotter, or other NMEA 0183 device that has a defined accessory signal wire. If you are wiring the GPS 19x to a device that does not have an accessory signal wire, the orange wire from the GPS 19x should be connected to ground.

Caution: If you are wiring the GPS 19x to a device that does not have an accessory signal wire, connect the GPS 19x power wire to the ignition or install an in-line switch. The GPS 19x can drain the battery of the boat if it is not switched.

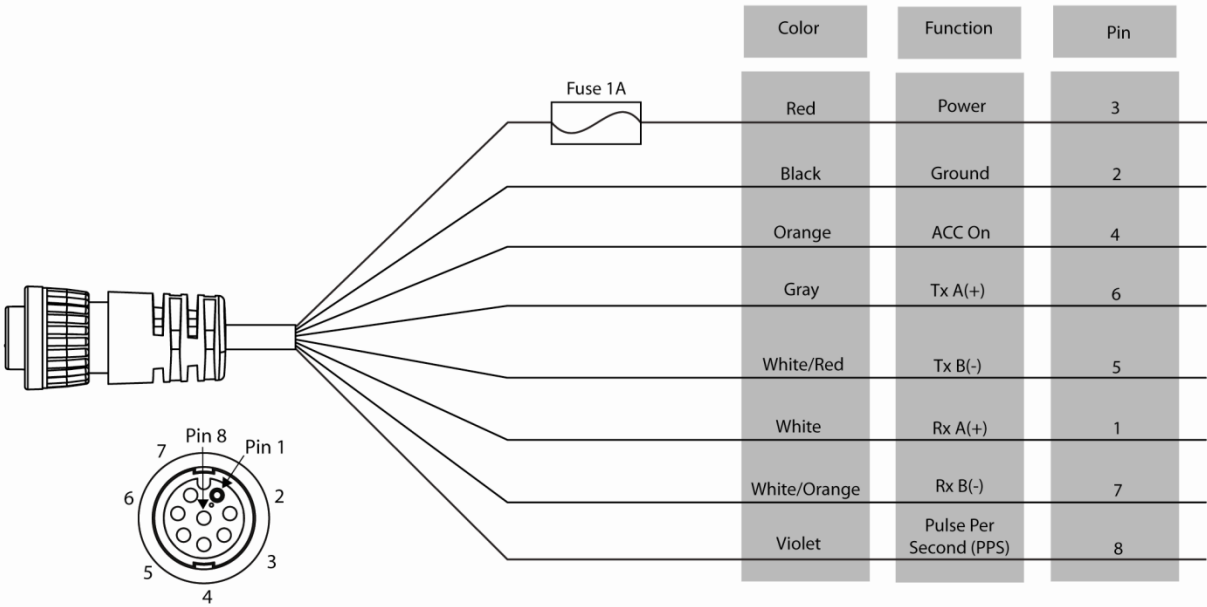

Figure 3b. GPS 19x NMEA 0183 HVS Power/Data Cable

3 **MECHANICAL CHARACTERISTICS & MOUNTING**

The following drawing shows an example for mounting hardware in case you wish to design your own custom mount. Figure 4a shows the dimensions of the bottom of the GPS 19x HVS surface-mount bracket. **This drawing is not to scale.**

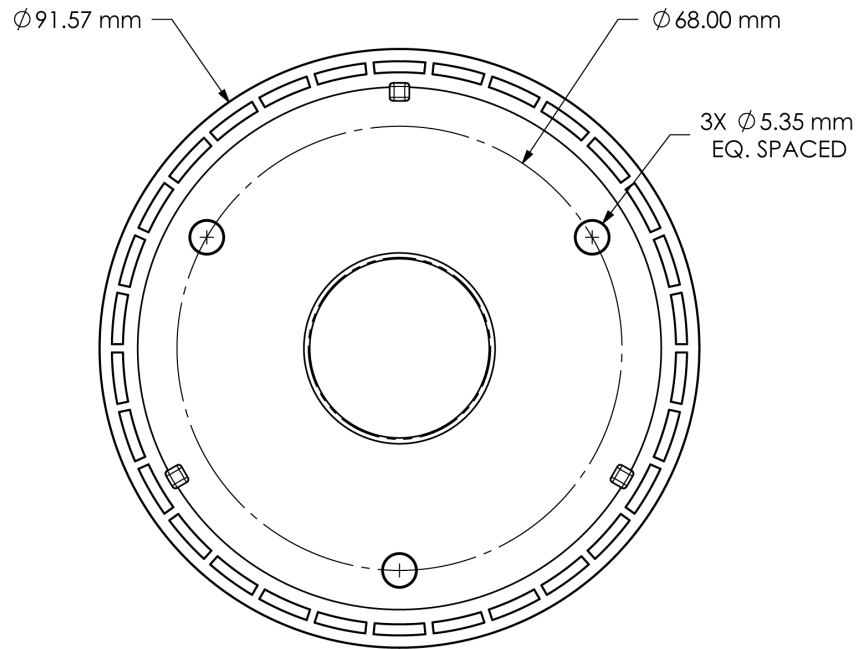

Figure 4. GPS 19x HVS Bottom Case Dimensions

4 GPS 19X HVS SOFTWARE INTERFACE

The interface protocol design of the GPS 19x HVS is based on the National Marine Electronics Association's NMEA 0183 ASCII interface specification. This standard is fully defined in *NMEA 0183, Version 2.30*. You can obtain a copy of the latest specification from NMEA, www.nmea.org.

In addition to the standard NMEA 0183 sentences, the GPS 19x HVS unit may also be configured to transmit information over its serial interface using NMEA 0183 compliant Garmin proprietary sentences. These proprietary sentences begin with the characters "\$PGRM", instead of the characters "\$G" that are typical of the standard NMEA 0183 sentences. The characters "\$P" indicate that the sentence is a proprietary implementation and the characters "GRM" indicate that it is Garmin's proprietary sentence. The letter (or letters) that follow the characters "\$PGRM" uniquely identifies that particular Garmin proprietary sentence.

It is also possible to configure the GPS 19x HVS to transmit binary data information over its serial interface. See [Appendix B: Garmin Binary Output Format](#) for details.

The following sections describe the NMEA 0183 data format of each sentence transmitted and received by the GPS 19x HVS.

4.1 RECEIVED NMEA 0183 SENTENCES

The following paragraphs define the sentences that can be received on the GPS sensor's port. Null fields in the configuration sentence indicate no change in the particular configuration parameter. All sentences received by the GPS sensor must be terminated with <CR><LF>, the ASCII characters for carriage return (0D hexadecimal) and line feed (0A hexadecimal). The checksum *hh is used for parity checking data and is not required, but is recommended for use in environments containing high electromagnetic noise. It is generally not required in normal PC environments. When used, the parity bytes (hh) are the ASCII representation of the exclusive-or (XOR) sum of all the characters between the "\$" and "*" characters, non-inclusive. The hex representation must be a capital letter, such as 3D instead of 3d. Sentences may be truncated by <CR><LF> after any data field and valid fields up to that point will be acted on by the sensor.

4.1.1 Almanac Information (GPALM)

The GPALM sentence can be used to initialize the GPS sensor's stored almanac information in the unlikely event of non-volatile memory loss or after storing longer than six months without tracking GPS satellites.

\$GPALM,<1>,<2>,<3>,<4>,<5>,<6>,<7>,<8>,<9>,<10>,<11>,<12>,<13>,<14>,<15>*hh<CR><LF>

<1>	Total number of ALM sentences to be transmitted by the GPS sensor during almanac download. This field can be null or any number when sending almanac to the GPS sensor.
<2>	Number of current ALM sentence. This field can be null or any number when sending almanac to the GPS sensor.
<3>	Satellite PRN number, 01 to 32
<4>	GPS week number
<5>	SV health, bits 17–24 of each almanac page
<6>	Eccentricity
<7>	Almanac reference time
<8>	Inclination angle
<9>	Rate of right ascension
<10>	Root of semi major axis
<11>	Omega, argument of perigee
<12>	Longitude of ascension node
<13>	Mean anomaly
<14>	af0 clock parameter
<15>	af1 clock parameter

4.1.2 Sensor Initialization Information (PGRMI)

The PGRMI sentence provides information used to initialize the GPS sensor's set position and time used for satellite acquisition. Receipt of this sentence by the GPS sensor causes the software to restart the satellite acquisition process. If there are no errors in the sentence, it will be echoed upon receipt. If an error is detected, the echoed PGRMI sentence will contain the current default values. Current PGRMI defaults (with the exception of the Receiver Command, which is a command rather than a mode) can also be obtained by sending the sentence "\$PGRMIE" to the GPS sensor.

\$PGRMI,<1>,<2>,<3>,<4>,<5>,<6>,<7>*hh<CR><LF>

<1>	Latitude, ddmm.mmm format for GPS 19x HVS (leading zeros must be transmitted)
<2>	Latitude hemisphere, N or S
<3>	Longitude, ddmm.mmm format for GPS 19x HVS (leading zeros must be transmitted)
<4>	Longitude hemisphere, E or W
<5>	Current UTC date, ddmmyy format
<6>	Current UTC time, hhmmss format for GPS 19x HVS
<7>	Receiver Command, A = Cold Start, R = Unit Reset

4.1.3 Sensor Configuration Information (PGRMC)

The PGRMC sentence provides information used to configure the GPS sensor's operation. Configuration parameters are stored in non-volatile memory and retained between power cycles. The GPS sensor will echo this sentence upon its receipt if no errors are detected. If an error is detected, the echoed PGRMC sentence will contain the current default values. Current default values can also be obtained by sending the sentence "\$PGRMCE" to the GPS sensor.

\$PGRMC,<1>,<2>,<3>,<4>,<5>,<6>,<7>,<8>,<9>,<10>,<11>,<12>,<13>,<14>*hh<CR><LF>

<1>	Fix mode, A = Automatic, 3 = 3D exclusively
<2>	Altitude above/below mean sea level, -1500.0 to 18000.0 meters
<3>	Earth datum index. If the user datum index (96) is specified, fields <4> through <8> must contain valid values. Otherwise, fields <4> through <8> must be null. Refer to Appendix A: Earth Datum List for a list of earth datum and the corresponding earth datum index.
<4>	User earth datum semi-major axis, 6360000.000 to 6380000.000 meters (.001 meters resolution)
<5>	User earth datum inverse flattening factor, 285.0 to 310.0 (10 ⁻⁹ resolution)
<6>	User earth datum delta x earth centered coordinate, -5000.0 to 5000.0 meters (1 meter resolution)
<7>	User earth datum delta y earth centered coordinate, -5000.0 to 5000.0 meters (1 meter resolution)
<8>	User earth datum delta z earth centered coordinate, -5000.0 to 5000.0 meters (1 meter resolution)
<9>	Differential mode, A = Automatic (output DGPS data when available, non-DGPS otherwise), D = Differential exclusively (output only differential fixes)
<10>	NMEA 0183 Baud rate, 1 = 1200, 2 = 2400, 3 = 4800, 4 = 9600, 5 = 19200, 6 = 300, 7 = 600, 8 = 38400
<11>	Velocity filter, 0 = No filter, 1 = Automatic filter, 2 to 255 = Filter time constant (e.g. 10 = 10 second filter)
<12>	Measurement Pulse Output, 1 = Disabled, 2 = Enabled
<13>	Measurement Pulse Output pulse length, (n+1)*20 ms n = 0 through 48 (max. 980 ms) Example: n = 4 corresponds to a 100 ms wide pulse
<14>	Dead reckoning valid time 1 to 30 sec. for the GPS 19x HVS

All configuration changes take effect after receipt of a valid value except baud rate. Baud rate changes take effect on the next power cycle or an external reset event.

4.1.4 Additional Sensor Configuration Information (PGRMC1)

The PGRMC1 sentence provides additional information used to configure the GPS sensor operation. Configuration parameters are stored in non-volatile memory and retained between power cycles. The GPS sensor will echo this sentence upon its receipt if no errors are detected. If an error is detected, the echoed PGRMC1 sentence will contain the current default values. Current default values can also be obtained by sending the sentence "\$PGRMC1E" to the GPS sensor.

\$PGRMC1,<1>,<2>,<3>,<4>,<5>,<6>,<7>,<8>,<9>,<10>,<11>,<12>,<13>*hh<CR><LF>

<1>	NMEA 0183 output time 1 to 900 (sec).
<2>	Binary Output Data, 1 = Off, 2 = On.
<3>	Low Velocity Position Filter (1 = Off, 2 = On)
<4>	No Effect (DGPS beacon frequency: 0.0, 283.5 to 325.0 kHz in 0.5 kHz steps)
<5>	No Effect (DGPS beacon bit rate: 0, 25, 50, 100, or 200 bps)
<6>	No Effect (DGPS beacon scanning, 1 = Off, 2 = On)
<7>	NMEA 0183 version 2.30 mode indicator, 1 = Off, 2 = On
<8>	DGPS WAAS mode, W = WAAS Enabled, N = WAAS Disabled
<9>	Power Save Mode, P = Power Save mode, N = Normal
<10>	No Effect (This field is not used on this model and is included only for backward compatibility)
<11>	No Effect (This field is not used on this model and is included only for backward compatibility)
<12>	No Effect (This field is not used on this model and is included only for backward compatibility)
<13>	Measurement Pulse Output Auto Off Mode, 1 = Off, 2 = On

Configuration changes take effect immediately, with the exception of Binary Output Data, which takes effect on the next power cycle or a reset event. Send the sentence "\$PGRMI,,,,,,R" to command a reset (refer to section 4.1.2 Sensor Information (PGRMI)). If the GPS sensor is in the Binary data mode, it is necessary to send the following eight-byte data stream to temporarily change the data format to NMEA 0183:

10 0A 02 26 00 CE 10 03 (Hexadecimal)

Then send PGRMC1 with field 2 set to turn off the Binary Output Data format.

4.1.5 Additional Sensor Configuration Information 2 (PGRMC2)

The PGRMC2 sentence can be used to control sensor operation parameters that are newly introduced with GPS19x. Configuration parameters are stored in non-volatile memory and retained between power cycles. The GPS sensor will echo this sentence upon its receipt if no errors are detected. If an error is detected, the echoed PGRMC2 sentence will contain the current default values. Current default values can also be obtained by sending the sentence "\$PGRMC2E" to the GPS sensor.

\$PGRMC2,<1>,<2>,<3>,<4>,<5>,<6>,<7>,<8>,<9>,<10>,<11>,<12>,<13>*hh<CR><LF>

<1>	Positioning update rate, 1 = once per second, 5 = five times per second, 10 = ten times per second.
<2>	GPS engine dynamics mode, LOW = low dynamics, HIGH = high dynamics
<3>	GNSS system name, GPS, GLONASS
<4>	GNSS system command, ON = enable, OFF = disable (the GNSS system specified in param <3>)
<5>	Talker ID, AUTO, GP, GL, GN (specified talker ID use for NMEA0183 output sentences)
<6>	Profile ID, PR0 = no resistor wire, PR1 = with resistor wire (specifies which configuration to affect)
<7>	NMEA0183 output compatible with GPS17x, 0 = not compatible, 1 = force compatible

Some configuration changes take effect immediately, some take effect after power is cycled. However, the intended use of PGRMC2 sentence is such that the sensor is power cycled or reset (using PGRMI) after all configuration sentences have been sent to and processed by GPS sensor.

Notes on use of PGRMC2 parameters:

Profile ID:

If the Profile ID parameter is supplied, it takes effect before any other parameters. All other supplied parameters will be applied to the configuration profile specified by the Profile ID parameter. Also, any other configuration sentences sent to the sensor will from now on affect the specified configuration profile until it is changed again or until sensor is power cycled or reset. If the Profile ID parameter is not supplied then the affected configuration is determined by the presence of the accessory resistor wire on the Accessory-ON signal line.

Positioning update rate:

The selected update rate determines how many times per second the sensor will produce a new positioning estimate. A higher update rate will cause NMEA output sentences to be transmitted more frequently. For example, if a 10Hz update rate is selected, then a new positioning estimate is produced once every 100ms and selected high priority (see description of PGRMO for explanation on priority) NMEA output sentences are transmitted every 100ms. When configuring the sensor to operate at higher positioning update rates, consider the combination of communication baud rate and NMEA output sentence selection. If the combination of configured positioning update rate and selected set of NMEA output sentences exceeds the serial bandwidth available at the configured baud rate, then some NMEA output messages will not be transmitted.

GPS engine dynamics mode:

When GPS engine is configured for HIGH dynamics mode, the sensor is able to produce more accurate positioning estimates in highly dynamic motion situations (rapid changes of direction and velocity). When it is configured for LOW dynamics mode the positioning estimates are more accurate in motion situations without highly dynamic maneuvers.

GNSS system name, GNSS system command:

If the GNSS system name parameter is supplied, then the GNSS system command parameter is also required to either enable or disable the use of a satellite system. The GPS19x always uses the GPS system, so use of GPS cannot be disabled. The sensor is configured by default to use both GPS and GLONASS satellites. Use of GLONASS can be enabled or disabled.

Talker ID:

When Talker ID is configured for AUTO, the transmitted NMEA output sentences will use the Talker ID in accordance with NMEA0183 standard. For example, when the sensor is tracking and using GPS and GLONASS at the same time, then most sentences will use Talker ID GN, but a few will be assigned a system-specific Talker ID (GPGSV and GLGSV). When Talker ID is configured to use a specific Talker ID, then all transmitted sentences will use the same specific Talker ID. This can result in non-standard output, but has been provided for flexibility.

NMEA0183 output compatible with GPS17x:

If this parameter is set to 1, then the affected GPS19x configuration profile will be set up to closely match the operation of GPS17x sensor. This includes setting the 1 Hz positioning update rate, LOW dynamics mode, and GP talker ID. In this mode, no information about GLONASS satellites will be output in NMEA output sentences even though the sensor is still using GLONASS satellites internally for positioning estimates.

4.1.6 Output Sentence Enable/Disable (PGRMO)

The PGRMO sentence provides the ability to enable and disable specific output sentences and assign them high or low transmission priority. The following sentences are enabled at the factory for the GPS 19x HVS: GPGGA, GPGSA, GPGSV, GPRMC, GPVTG and PGRMT.

\$PGRMO,<1>,<2>,<3>*hh<CR><LF>

<1>	Target sentence description (for example, PGRMT, GPGSV, etc.)
<2>	Target sentence mode, where 0 = Disable specified sentence, 1 = enable specified sentence, 2 = Disable all output sentences, 3 = Enable all output sentences (except GPALM), 4 = Restore factory default output sentences
<3>	Target sentence transmission priority: 0 = low priority, 1 = high priority

The following notes apply to the PGRMO input sentence:

If the target sentence mode is 2 (Disable all), 3 (Enable all), or 4 (Restore defaults), the target sentence description is not checked for validity. In this case, an empty field is allowed (for example, "\$PGRMO,,3"), or the mode field may contain from 1 to 5 characters.

If the target sentence mode is 0 (Disable) or 1 (Enable), the target sentence description field must be an identifier for one of the sentences that can be output by the GPS sensor. NOTE: Though GPS19x can output sentences with NMEA sentence Talker ID other than GP, the target sentence identifiers used for this configuration sentence still all use the GP Talker ID.

If either the target sentence mode field or the target sentence description field is not valid, the PGRMO sentence will have no effect.

If the target sentence is configured for high transmission priority, then this sentence will be transmitted every time the GPS sensor produces a new positioning estimate. If the target sentence is configured for low priority, then it will be transmitted at least once per second in the bandwidth that remains available after all high priority sentences are transmitted. If sensor is configured to operate at positioning rate of 10 times per second, enabled high priority sentences will be transmitted every 100ms and enabled low priority sentences will be transmitted in remaining bandwidth available in each 100ms interval. This priority scheme provides flexible configuration of NMEA0183 output. It provides a way to output maximum amount of information, while still maintain timing accuracy of high priority sentences.

Sending the sentence "\$PGRMO,GPALM,1" will cause the GPS sensor to transmit all stored almanac information for GPS satellites. Transmission of all other NMEA 0183 output sentences will be temporarily suspended.

Sending the sentence "\$PGRMO,GLMLA,1" will cause the GPS sensor to transmit all stored almanac information for GLONASS satellites. Transmission of all other NMEA 0183 output sentences will be temporarily suspended.

Sending the sentence "\$PGRMO,,G" will cause the COM port to change to Garmin Data Transfer format for the duration of the power cycle. The Garmin mode is required for GPS 19x HVS series product software updates.

4.2 TRANSMITTED NMEA 0183 SENTENCES

The subsequent paragraphs define the sentences that can be transmitted by the GPS 19x HVS.

4.2.1 Sentence Transmission Rate

Sentences are transmitted with respect to the user selected baud rate.

The GPS sensor will transmit sentences (except where noted in particular transmitted sentence descriptions) at a periodic rate based on following parameters:

- user selected positioning update rate (1,5 or 10 Hz)
- user selected serial baud rate
- user selected output sentences and their priority

The GPS sensor will transmit the selected sentences continuously. The length of the transmission can be determined by the following equation and Tables 2 and 3:

$$\text{length of transmission} = \frac{\text{total characters to be transmitted}}{\text{characters transmitted per second}}$$

Sentence	Output by Default?	Maximum Characters	Output rate (times/sec)
RMC	✓	74	1,5,10
GGA	✓	82	1,5,10
GSA	✓	66	1
GSV	✓	70	1
PGRME		35	1,5,10
GLL		44	1,5,10
VTG	✓	42	1,5,10
GNS		82	1,5,10
PGRMV		32	1,5,10
PGRMF		82	1,5,10
PGRMB		40	1,5,10
PGRMM			
PGRMT	✓	50	once per minute

Table 2: NMEA 0183 Output Sentence Order and Size

Baud	Characters per Second
4800	480

9600	960
19200	1920
38400	3840

Table 3: Characters per Second for Available Baud Rates

The maximum number of fields allowed in a single sentence is 82 characters including delimiters. Values in the table include the sentence start delimiter character "\$" and the termination delimiter <CR><LF>. For the GPS 19x HVS, the factory set defaults result in a once per second transmission at the NMEA 0183 specification transmission rate of 4800 baud.

Regardless of the selected baud rate, the information transmitted by the GPS sensor is referenced to the one-pulse-per-second output pulse immediately preceding the GPRMC sentence, or whichever other sentence is output first in the burst (see Table 2 above) if RMC sentence is not enabled.

4.2.2 Transmitted Time

The GPS sensor outputs Coordinated Universal Time (UTC) date and time of day in the transmitted sentences. If sensor is operating at positioning update rate of once per second then time output is of format HHMMSS. If sensor is operating at a higher positioning update rate then time also contains tenths of a second and is of format HHMMSS.T .

Before the initial position fix, the on-board clock provides the date and time of day. After the initial position fix, the date and time of day are calculated using GPS satellite information and are synchronized with the measurement pulse output.

The GPS sensor uses information obtained from the GPS satellites to add or delete UTC leap seconds and correct the transmitted date and time of day. The transmitted date and time of day for leap second correction follow the guidelines in "*National Institute of Standards and Technology Special Publication 432 (Revised 1990)*" (for sale by the Superintendent of Documents, U.S. Government Printing Office, Washington, D.C., 20402, U.S.A.).

When a positive leap second is required, one second is inserted at the beginning of the first hour (0h 0m 0s) of the day that the positive leap is occurring. The minute containing the leap second is 61 seconds long. The GPS sensor would have transmitted this information for the leap second added December 31, 1998 as follows:

\$GPRMC,235959,A,3851.3651,N,09447.9382,W,000.0,221.9,071103,003.3,E*69

\$GPRMC,000000,A,3851.3651,N,09447.9382,W,000.0,221.9,081103,003.3,E*67

\$GPRMC,000000,A,3851.3651,N,09447.9382,W,000.0,221.9,081103,003.3,E*67

\$GPRMC,000001,A,3851.3651,N,09447.9382,W,000.0,221.9,081103,003.3,E*66

If a negative leap second should be required, one second will be deleted at the end of some UTC month. The minute containing the leap second will be only 59 seconds long. In this case, the GPS sensor will not transmit the time of day 0h 0m 0s (the "zero" second) for the day from which the leap second is removed.

\$GPRMC,235959,A,3851.3650,N,09447.9373,W,000.0,000.0,111103,003.3,E*69

\$GPRMC,000001,A,3851.3650,N,09447.9373,W,000.0,000.0,121103,003.3,E*6A

\$GPRMC,000002,A,3851.3650,N,09447.9373,W,000.0,000.0,121103,003.3,E*69

4.2.3 Global Positioning System Almanac Data (GPALM)

GPS almanac sentences are normally not transmitted. Send the GPS sensor the sentence "\$PGRMO,GPALM,1" to initiate almanac transmission. Upon receipt, the GPS sensor will transmit available almanac information using GPALM sentences. During the transmission of almanac sentences, other NMEA 0183 data output is suspended temporarily.

\$GPALM,<1>,<2>,<3>,<4>,<5>,<6>,<7>,<8>,<9>,<10>,<11>,<12>,<13>,<14>,<15>*hh<CR><LF>

<field information> can be found in section [4.1.1 Almanac Information \(GPALM\)](#).

4.2.4 GLONASS System Almanac Data (GLMLA)

GLONASS almanac sentences are not transmitted by default. Send the \$PGRMO,GLMLA,1 sentence to the GPS sensor to initiate GLONASS almanac transmission. Upon receipt, the GPS sensor will transmit available almanac information using GLMLA sentences. During the transmission of almanac sentences, output of other NMEA 0183 sentences is temporarily suspended.

\$GLMLA,<1>,<2>,<3>,<4>,<5>,<6>,<7>,<8>,<9>,<10>,<11>,<12>,<13>,<14>,<15>*hh<CR><LF>

<1>	Total number of MLA sentences to be transmitted by the GPS sensor during GLONASS almanac download.
<2>	Number of current MLA sentence.
<3>	Satellite ID (slot) number, 01 to 32
<4>	Calendar day count within the four year period beginning with the previous leap year
<5>	SV health (bit 7) and carrier frequency number (5 LSB bits)
<6>	Eccentricity (15 LSB bits)
<7>	(Delta TnA) DOT, rate of change of draconitic circling time (7 LSB bits)
<8>	Omega, argument of perigee
<9>	Tau cA, system time scale correction (16 MSB)
<10>	Delta TnA, correction to the average value of draconitic circling time (24 bits)
<11>	Time of the ascension node, almanac reference time (21 bits)
<12>	Greenwich longitude of ascension node (21 bits)
<13>	Delta InA, correction of the average value of the inclination angle (20 bits)
<14>	Tau cA, system time scale correction (12 LSB)
<15>	Tau nA, course value of the time scale shift (10 bits)

4.2.5 Global Positioning System Fix Data (GGA)

\$.GGA,<1>,<2>,<3>,<4>,<5>,<6>,<7>,<8>,<9>,M,<10>,M,<11>,<12>*hh<CR><LF>

<1>	UTC time of position fix, hhmmss or hhmmss.t format for GPS 19x HVS
<2>	Latitude, ddmm.mmmm format for GPS 19x HVS (leading zeros will be transmitted)
<3>	Latitude hemisphere, N or S
<4>	Longitude, dddmm.mmmm format for GPS 19x HVS (leading zeros will be transmitted)
<5>	Longitude hemisphere, E or W
<6>	GPS quality indication, 0 = fix not available, 1 = Non-differential GPS fix available, 2 = Differential GPS (WAAS) fix available, 6 = Estimated
<7>	Number of satellites in use, 00 to 12 (leading zeros will be transmitted)
<8>	Horizontal dilution of precision, 0.5 to 99.9
<9>	Antenna height above/below mean sea level, -9999.9 to 99999.9 meters
<10>	Geoidal height, -999.9 to 9999.9 meters
<11>	Null (Differential GPS)
<12>	Null (Differential Reference Station ID)

4.2.6 GPS DOP and Active Satellites (GSA)

\$.GSA,<1>,<2>,<3>,<3>,<3>,<3>,<3>,<3>,<3>,<3>,<3>,<3>,<3>,<3>,<3>,<3>,<4>,<5>,<6>*hh<CR><LF>

<1>	Mode, M = Manual, A = Automatic
<2>	Fix type, 1 = not available, 2 = 2D, 3 = 3D
<3>	PRN number, 01 to 32, of satellite used in solution, up to 12 transmitted (leading zeros will be transmitted)
<4>	Position dilution of precision, 0.5 to 99.9
<5>	Horizontal dilution of precision, 0.5 to 99.9
<6>	Vertical dilution of precision, 0.5 to 99.9

4.2.7 GPS and GLONASS Satellites in View (GPGSV and GLGSV)

\$.GSV,<1>,<2>,<3>,<4>,<5>,<6>,<7>,...<4>,<5>,<6>,<7>*hh<CR><LF>

<1>	Total number of GSV sentences to be transmitted
<2>	Number of current GSV sentence
<3>	Total number of satellites in view, 00 to 12 (leading zeros will be transmitted)
<4>	Satellite PRN number, 01 to 32 (leading zeros will be transmitted)
<5>	Satellite elevation, 00 to 90 degrees (leading zeros will be transmitted)
<6>	Satellite azimuth, 000 to 359 degrees, true (leading zeros will be transmitted)
<7>	Signal to noise ratio (C/No) 00 to 99 dB (leading zeros will be transmitted)

Note: Items <4>, <5>, <6>, and <7> repeat for each satellite in view to a maximum of four (4) satellites per sentence.

4.2.8 Recommended Minimum Specific GPS/TRANSIT Data (RMC)

\$.RMC,<1>,<2>,<3>,<4>,<5>,<6>,<7>,<8>,<9>,<10>,<11>,<12>*hh<CR><LF>

<1>	UTC time of position fix, hhmmss format for GPS 19x HVS
<2>	Status, A = Valid position, V = NAV receiver warning
<3>	Latitude, ddm.ddd format for GPS 19x HVS (leading zeros must be transmitted)
<4>	Latitude hemisphere, N or S
<5>	Longitude, dddmm.mmmm format for GPS 19x HVS leading zeros must be transmitted)
<6>	Longitude hemisphere, E or W
<7>	Speed over ground, GPS 19x HVS: 000.0 to 999.9 knots (leading zeros will be transmitted)
<8>	Course over ground, 000.0 to 359.9 degrees, true (leading zeros will be transmitted)
<9>	UTC date of position fix, ddmmyy format
<10>	Magnetic variation, 000.0 to 180.0 degrees (leading zeros will be transmitted)
<11>	Magnetic variation direction, E or W (westerly variation adds to true course)
<12>	Mode indicator (only output if NMEA 0183 version 2.30 active), A = Autonomous, D = Differential, E = Estimated, N = Data not valid

4.2.9 Track Made Good and Ground Speed (VTG)

\$.VTG,<1>,T,<2>,M,<3>,N,<4>,K,<5>*hh<CR><LF>

<1>	True course over ground, GPS 19x HVS: 000 to 359 degrees (leading zeros will be transmitted)
<2>	Magnetic course over ground, 000 to 359 degrees (leading zeros will be transmitted)
<3>	Speed over ground, GPS 19x HVS: 000.0 to 999.9 knots (leading zeros will be transmitted)
<4>	Speed over ground, GPS 19x HVS: 0000.0 to 1851.8 kilometers per hour (leading zeros will be transmitted)
<5>	Mode indicator (only output if NMEA 0183 version 2.30 active), A = Autonomous, D = Differential, E = Estimated, N = Data not valid

4.2.10 Geographic Position (GLL)

\$.GLL,<1>,<2>,<3>,<4>,<5>,<6>,<7>*hh<CR><LF>

<1>	Latitude, ddm.ddd format for GPS 19x HVS (leading zeros must be transmitted)
<2>	Latitude hemisphere, N or S
<3>	Longitude, dddmm.mmmm format for GPS 19x HVS (leading zeros must be transmitted)
<4>	Longitude hemisphere, E or W
<5>	UTC time of position fix, hhmmss format for GPS 19x HVS
<6>	Status, A = Valid position, V = NAV receiver warning
<7>	Mode indicator (only output if NMEA 0183 version 2.30 active), A = Autonomous, D = Differential, E = Estimated, N = Data not valid

4.2.11 Estimated Error Information (PGRME)

\$PGRME,<1>,M,<2>,M,<3>,M*hh<CR><LF>

<1>	Estimated horizontal position error (HPE), 0.0 to 999.9 meters
<2>	Estimated vertical position error (VPE), 0.0 to 999.9 meters
<3>	Estimated position error (EPE), 0.0 to 999.9 meters

4.2.12 GPS Fix Data Sentence (PGRMF)

\$PGRMF,<1>,<2>,<3>,<4>,<5>,<6>,<7>,<8>,<9>,<10>,<11>,<12>,<13>,<14>,<15>*hh<CR><LF>

<1>	GPS week number (0 to 1023)
<2>	GPS seconds (0 to 604799)
<3>	UTC date of position fix, ddmmyy format
<4>	UTC time of position fix, hhmmss format for GPS 19x HVS
<5>	GPS leap second count
<6>	Latitude, ddmm.mmmm format for GPS 19x HVS (leading zeros must be transmitted)
<7>	Latitude hemisphere, N or S
<8>	Longitude, dddmm.mmmm format for GPS 19x HVS (leading zeros must be transmitted)
<9>	Longitude hemisphere, E or W
<10>	Mode, M = Manual, A = Automatic
<11>	Fix type, 0 = no fix, 1 = 2D fix, 2 = 3D fix
<12>	Speed over ground, 0 to 1851 kilometers/hour
<13>	Course over ground, 0 to 359 degrees, true
<14>	Position dilution of precision, 0 to 9 (rounded to nearest integer value)
<15>	Time dilution of precision, 0 to 9 (rounded to nearest integer value)

4.2.13 Map Datum (PGRMM)

The Garmin Proprietary sentence PGRMM gives the name of the map datum currently in use by the GPS sensor. This information is used by the Garmin MapSource real-time plotting application.

\$PGRMM,<1>*hh<CR><LF>

<1>	Name of map datum currently in use (variable length field, for example, "WGS 84")
-----	---

4.2.14 Sensor Status Information (PGRMT)

The Garmin Proprietary sentence PGRMT gives information concerning the status of the GPS sensor. This sentence is transmitted once per minute regardless of the selected baud rate.

\$PGRMT,<1>,<2>,<3>,<4>,<5>,<6>,<7>,<8>,<9>*hh<CR><LF>

<1>	Product, model and software version (variable length field, for example, "GPS 19x HVS VER 2.05")
<2>	No Effect (This field is not used on this model and is included only for backward compatibility)
<3>	No Effect (This field is not used on this model and is included only for backward compatibility)
<4>	No Effect (This field is not used on this model and is included only for backward compatibility)
<5>	No Effect (This field is not used on this model and is included only for backward compatibility)
<6>	No Effect (This field is not used on this model and is included only for backward compatibility)
<7>	No Effect (This field is not used on this model and is included only for backward compatibility)
<8>	No Effect (This field is not used on this model and is included only for backward compatibility)
<9>	No Effect (This field is not used on this model and is included only for backward compatibility)

4.2.15 3D Velocity Information (PGRMV)

\$PGRMV,<1>,<2>,<3>*hh<CR><LF>

<1>	True east velocity, -514.4 to 514.4 meters/second for GPS 19x HVS
-----	---

<2>	True north velocity, -514.4 to 514.4 meters/second for GPS 19x HVS
<3>	Up velocity, -999.9 to 999.9 meters/second for GPS 19x HVS

4.2.16 DPGS Beacon Information (PGRMB)

Note: The GPS 19x HVS does not support RTCM as a differential source. PGRMB is provided for backward compatibility.

\$PGRMB,<1>,<2>,<3>,<4>,<5>,K,<6>,<7>,<8>*hh<CR><LF>

<1>	No Effect (This field is not used on this model and is included only for backward compatibility)
<2>	No Effect (This field is not used on this model and is included only for backward compatibility)
<3>	No Effect (This field is not used on this model and is included only for backward compatibility)
<4>	No Effect (This field is not used on this model and is included only for backward compatibility)
<5>	Distance to beacon reference station in kilometers
<6>	No Effect (This field is not used on this model and is included only for backward compatibility)
<7>	DGPS fix source (R = RTCM, W = WAAS, N = Non-DGPS Fix)
<8>	DGPS mode, A = Automatic, W = WAAS Only, R = RTCM Only, N = None (DGPS disabled)

4.3 BAUD RATE SELECTION

Baud rate selection can be performed by sending the appropriate configuration sentence to the GPS sensor as described in the PGRMC section [4.1.2 Sensor Initialization Information \(PGRMI\)](#), field <10>.

4.4 MEASUREMENT PULSE OUTPUT

4.4.1 One-Pulse-Per-Second (PPS) Output

The highly accurate one-pulse-per-second (PPS) output is provided for applications requiring precise timing measurements. After the initial position fix has been calculated, the PPS signal is generated and continues until the unit is powered down. The rising edge of the signal is aligned to the start of each GPS second within 1 μ s for all conditions in which the receiver has reported a valid and accurate position for at least the previous 4 seconds.

The NMEA 0183 sentences that follow each rising edge of the PPS signal tell when you were and where you were at that previous rising edge of the PPS signal, beginning with the RMC sentence as the lead sentence in any particular NMEA 0183 record. If RMC sentence is not enabled then another sentence will be the lead sentence.

Regardless of the selected baud rate, the information transmitted by the GPS 19x HVS is referenced to the pulse immediately preceding the NMEA 0183 RMC sentence.

The accuracy of the one-pulse-per-second output is maintained only while the GPS receiver is computing a valid position fix. To obtain the most accurate results, the one-pulse-per-second output should be calibrated against a local time reference to compensate for cable and internal receiver delays and the local time bias.

The default pulse width is 100 ms, however; it may be programmed in 20 ms increments between 20 ms and 980 ms as described in PGRMC section [4.1.2 Sensor Initialization Information \(PGRMI\)](#), field <13>.

APPENDIX A: EARTH DATUM LIST

The following is a list of the Garmin GPS 19x HVS Earth datum indices and the corresponding earth datum name (including the area of application):

0	ADINDAN–Ethiopia, Mali, Senegal, Sudan
9	AUSTRALIAN GEODETIC 1984–Australia, Tasmania Island
10	ASTRO DOS 71/4–St. Helena Island
11	ASTRONOMIC STATION 1952–Marcus Island
12	ASTRO B4 SOROL ATOLL–Tern Island
13	BELLEVUE (IGN)–Efate and Erromango Islands
14	BERMUDA 1957–Bermuda Islands
15	BOGOTA OBSERVATORY–Colombia
16	CAMPO INCHAUSPE–Argentina
17	CANTON ASTRO 1966–Phoenix Islands
18	CAPE CANAVERAL–Florida, Bahama Islands
19	CAPE–South Africa
20	CARTHAGE–Tunisia
21	CHATHAM 1971–Chatham Island (New Zealand)
22	CHUA ASTRO–Paraguay
23	CORREGO ALEGRE–Brazil
24	DJAKARTA (BATAVIA)–Sumatra Island (Indonesia)
25	DOS 1968–Gizo Island (New Georgia Islands)
26	EASTER ISLAND 1967–Easter Island
27	EUROPEAN 1950–Austria, Belgium, Denmark, Finland, France, Germany, Gibraltar, Greece, Italy, Luxembourg, Netherlands, Norway, Portugal, Spain, Sweden, Switzerland
28	EUROPEAN 1979–Austria, Finland, Netherlands, Norway, Spain, Sweden, Switzerland
29	FINLAND HAYFORD 1910–Finland
30	GANDAJIKA BASE–Republic of Maldives
31	GEODETIC DATUM 1949–New Zealand
32	ORDNANCE SURVEY OF GREAT BRITAIN 1936–England, Isle of Man, Scotland, Shetland Islands, Wales
33	GUAM 1963–Guam Island
34	GUX 1 ASTRO–Guadalcanal Island
35	HJORSEY 1955–Iceland
36	HONG KONG 1963–Hong Kong
37	INDIAN–Bangladesh, India, Nepal
38	INDIAN–Thailand, Vietnam
39	IRELAND 1965–Ireland
40	ISTS O73 ASTRO 1969–Diego Garcia
41	JOHNSTON ISLAND 1961–Johnston Island
42	KANDAWALA–Sri Lanka
43	KERGUELEN ISLAND–Kerguelen Island
44	KERTAUI 1948–West Malaysia, Singapore

- 45 L.C. 5 ASTRO–Cayman Brac Island
- 46 LIBERIA 1964–Liberia
- 47 LUZON–Mindanao Island
- 48 LUZON–Phillippines (excluding Mindanao Island)
- 49 MAHE 1971–Mahe Island
- 50 MARCO ASTRO–Salvage Islands
- 51 MASSAWA–Eritrea (Ethiopia)
- 52 MERCHICH–Morocco
- 53 MIDWAY ASTRO 1961–Midway Island
- 54 MINNA–Nigeria
- 55 NORTH AMERICAN 1927–Alaska
- 56 NORTH AMERICAN 1927–Bahamas (excluding San Salvador Island)
- 57 NORTH AMERICAN 1927–Central America (Belize, Costa Rica, El Salvador, Guatemala, Honduras, Nicaragua)
- 58 NORTH AMERICAN 1927–Canal Zone
- 59 NORTH AMERICAN 1927–Canada (including Newfoundland Island)
- 60 NORTH AMERICAN 1927–Caribbean (Barbados, Caicos Islands, Cuba, Dominican Republic, Grand Cayman, Jamaica, Leeward Islands, Turks Islands)
- 61 NORTH AMERICAN 1927–Mean Value (CONUS)
- 62 NORTH AMERICAN 1927–Cuba
- 63 NORTH AMERICAN 1927–Greenland (Hayes Peninsula)
- 64 NORTH AMERICAN 1927–Mexico
- 65 NORTH AMERICAN 1927–San Salvador Island
- 66 NORTH AMERICAN 1983–Alaska, Canada, Central America, CONUS, Mexico
- 67 NAPARIMA, BWI–Trinidad and Tobago
- 68 NAHRWAN–Masirah Island (Oman)
- 69 NAHRWAN–Saudi Arabia
- 70 NAHRWAN–United Arab Emirates
- 71 OBSERVATORIO 1966–Corvo and Flores Islands (Azores)
- 72 OLD EGYPTIAN–Egypt
- 73 OLD HAWAIIAN–Mean Value
- 74 OMAN–Oman
- 75 PICO DE LAS NIEVES–Canary Islands
- 76 PITCAIRN ASTRO 1967–Pitcairn Island
- 77 PUERTO RICO–Puerto Rico, Virgin Islands
- 78 QATAR NATIONAL–Qatar
- 79 QORNOQ–South Greenland
- 80 REUNION–Mascarene Island
- 81 ROME 1940–Sardinia Island
- 82 RT 90–Sweden
- 83 PROVISIONAL SOUTH AMERICAN 1956–Bolivia, Chile, Colombia, Ecuador, Guyana, Peru, Venezuela

- 84 SOUTH AMERICAN 1969—Argentina, Bolivia, Brazil, Chile, Colombia, Ecuador, Guyana, Paraguay, Peru, Venezuela, Trinidad and Tobago
- 85 SOUTH ASIA—Singapore
- 86 PROVISIONAL SOUTH CHILEAN 1963—South Chile
- 87 SANTO (DOS)—Espirito Santo Island
- 88 SAO BRAZ—Sao Miguel, Santa Maria Islands (Azores)
- 89 SAPPER HILL 1943—East Falkland Island
- 90 SCHWARZECK—Namibia
- 91 SOUTHEAST BASE—Porto Santo and Madeira Islands
- 92 SOUTHWEST BASE—Faial, Graciosa, Pico, Sao Jorge, and Terceira Islands (Azores)
- 93 TIMBALAI 1948—Brunei and East Malaysia (Sarawak and Sabah)
- 94 TOKYO—Japan, Korea, Okinawa
- 95 TRISTAN ASTRO 1968—Tristan da Cunha
- 96 User defined earth datum
- 97 VITI LEVU 1916—Viti Levu Island (Fiji Islands)
- 98 WAKE-ENIWETOK 1960—Marshall Islands
- 99 WORLD GEODETIC SYSTEM 1972
- 100 WORLD GEODETIC SYSTEM 1984
- 101 ZANDERIJ—Surinam
- 102 CH-1903—Switzerland
- 103 Hu-Tzu-Shan
- 104 Indonesia 74
- 105 Austria
- 106 Potsdam
- 107 Taiwan—modified Hu-Tzu-Shan
- 108 GDA—Geocentric Datum of Australia
- 109 Dutch

APPENDIX B: GARMIN BINARY OUTPUT FORMAT

In Binary Output mode, the GPS 19x HVS will transmit position packets at the rate of positioning update rate and satellite information packets once every second. The record is sent at a default baud rate of 9600 baud, 8 data bits, and no parity. For operation at positioning update rate of 10 times per second the baud rate may have to be negotiated to a higher one to avoid loss of packets.

To turn this record on, use the PGRMC1 NMEA sentence as described in section 4 [GPS 19x HVS Software Interface](#). Refer to the *Garmin Device Interface Specification* found in the Garmin Device Interface SDK for details on how to form and parse Garmin packets. At the time of publication, this document is located on the Garmin Web site at <https://www8.garmin.com/support/commProtocol.html>.

Records sent over RS-232 begin with a delimiter byte (10 hex). The second byte identifies the record type (33 hex for a position record, 34 hex for a receiver measurement and 72 hex for a satellite data record). The third byte indicates the size of the data. The fourth byte is the first byte of data. The data is then followed by a checksum byte, a delimiter byte (10 hex), and an end-of-transmission character (03 hex). Additionally, any DLEs (0x10) that appear between the delimiters are escaped with a second DLE. There is sample code at the end of this section that will strip off the DLEs and ETXs.

RS-232 Packet:

- 0x10 (DLE is first byte)
- 0x## (Record ID – single byte)
- 0x## (Number of data bytes – single byte)
- data bytes (See descriptions below)
- 0x## (2's complement of the arithmetic sum of the bytes between the delimiters)
- 0x10 (DLE)
- 0x03 (ETX is last byte)

The data bytes of each packet contain the record specified by the record ID. A description of each record follows.

Satellite Data Record

The satellite data has a record ID of 0x72 with 84 (0x54) data bytes. The data bytes contain data for 12 satellites as described below.

```
typedef      struct
{
    uint8      svid; //space vehicle identification (1-32 and 33-64 for
SBAS (WAAS/EGNOS/MSAS) )
    uint16     snr;   //signal-to-noise ratio
    uint8      elev; //satellite elevation in degrees
    uint16     azmth; //satellite azimuth in degrees
    uint8      status; //status bit-field
} cpo_sat_data;
```

The status bit field represents a set of booleans described below:

Bit	Meaning when bit is one (1)
0	The unit has ephemeris data for the specified satellite.
1	The unit has a differential correction for the specified satellite.
2	The unit is using this satellite in the solution.

This pattern is repeated for 12 satellites for a total of 12 X 7 bytes = 84 (0x54) bytes.

The RS-232 Packet for the Satellite Record looks like:

- 0x10 (DLE is first byte)
- 0x72 (Record ID – single byte)
- 0x54 (Number of data bytes – single byte)
- 12 cpo_sat_data records
- 0x## (2's complement of the arithmetic sum of the bytes between the delimiters)
- 0x10 (DLE)
- 0x03 (ETX is last byte)

Position Record

The Position Record has a record identifier of

```
typedef struct
```

```
{  
    float    alt;  
    float    epe;  
    float    eph;  
    float    epv;  
    int      fix;  
    double   gps_tow;  
    double   lat;  
    double   lon;  
    float    lon_vel;  
    float    lat_vel;  
    float    alt_vel;  
    float    msl_hght;  
    int      leap_sec;  
    long     grmn_days;  
} cpo_pvt_data;
```

alt	Ellipsoid altitude (meters)
epe	Estimated position error (meters)
eph	Position error, horizontal (meters)
epv	Position error, vertical (meters)
fix	0 = no fix; 1 = no fix; 2 = 2D; 3 = 3D; 4 = 2D differential; 5 = 3D differential; 6 and greater = not defined
gps_tow	GPS time of week (sec)
lat	Latitude (radians)
lon	Longitude (radians)
lon_vel	Longitude velocity (meters/second)
lat_vel	Latitude velocity (meters/second)
alt_vel	Altitude velocity (meters/second)

msl_hght Height (mean sea level) (meters)
leap_sec UTC leap seconds
grmn_days Garmin days (days since December 31, 1989)

DLE and ETX bytes:

Sample C code to receive the two records should filter DLE and ETX bytes as described below:

```
typedef enum
{
    DAT,
    DLE,
    ETX
} rx_state_type;

/* Declare and initialize static variables */
static char      in_que[ 256 ];
static int       in_que_ptr = 0;
static rx_state_type rx_state = DAT;

.
.
.

void add_to_que( char data )
{
#define DLE_BYTE 0x10
#define ETX_BYTE 0x03

if ( rx_state == DAT )
{
    if ( data == DLE_BYTE )
    {
        rx_state = DLE;
    }
    else
    {
        in_que[ in_que_ptr++ ] = data;
    }
}
else if ( rx_state == DLE )
{
    if ( data == ETX_BYTE )
```

```
    {
        rx_state = ETX;
    }
else
    {
        rx_state = DAT;
        in_que[ in_que_ptr++ ] = data;
    }
}
else if ( rx_state == ETX )
    {
        if ( data == DLE_BYTE )
            {
                rx_state = DLE;
            }
    }

if ( in_que_ptr > 255 )
    {
        in_que_ptr = 0;
    }
}
```

APPENDIX C: CHANGING THE BAUD RATE IN GARMIN MODE

In certain cases, you may need to change the default baud rate of your Garmin GPS receiver while in Garmin mode. Follow these steps to temporarily change the baud rate.

Refer to the *Garmin Device Interface Specification* found in the Garmin Device Interface SDK for details on how to form and parse Garmin packets. At the time of this printing, these specs are available from the technical support section of our Web site: <https://www8.garmin.com/support/commProtocol.html>.

1. Turn off all requests by transmitting packet:

id = IOP_RQST_DATA (0x1C)
data = 0 (16-bit unsigned integer)

2. The GPS unit will respond by sending a packet with id = IOP_ACK_BYTE (0x06)

3. After you receive the above packet, transmit packet:

id = IOP_BAUD_RQST_DATA (0x30)
data = baud rate to change to (32-bit unsigned integer; for example, 38400)

4. The GPS unit will respond by sending a packet:

id = IOP_BAUD_ACPT_DATA (0x31)
data = highest acceptable baud rate closest to what was requested
(32-bit unsigned integer; for example, 38361 decimal)

5. Determine the actual baud rate value from the data sent in step 4. This value will be within +/- 5% of the actual baud rate. (For example, the GPS unit might send a baud rate of 38361, which correlates to a baud rate of 38400).

6. If the baud rate in step 5 is acceptable, transmit packet:

id = IOP_ACK_BYTE (0x06)
data = IOP_BAUD_ACPT_DATA (0x31)

7. Sleep for a small amount of time, about 100 milliseconds, to make sure the packet in (6) was successfully transmitted to the GPS unit.

8. Close the current connection to the GPS unit and immediately open a new connection with the new baud rate obtained in step 5.

9. Immediately after establishing a connection, transmit packet:

id = IOP_CMND_DATA (0x0A)
data = IOP_ACK_PING (0x3A)

10. The GPS will respond by sending a packet:

id = IOP_ACK_BYTE (0x06)
data = IOP_CMND_DATA (0x0A)

11. After you receive the above packet, transmit the same packet in step 9 again.

id = IOP_CMND_DATA (0x0A)
data = IOP_ACK_PING (0x3A)

12. The GPS will respond again with the same packet in step 10.

id = IOP_ACK_BYTE (0x06)
data = IOP_CMND_DATA (0x0A)

13. The baud rate has been successfully changed upon receiving the above packet. If the GPS unit does not receive these two IOP_CMND_DATA packets within two seconds, it will reset its baud rate to 9600.

APPENDIX D: GPS 19X HVS AND WINDOWS SERIAL MOUSE ISSUE

Problem: It is possible for Windows to incorrectly interpret the NMEA 0183 output of the GPS 19x HVS as the output of a Microsoft Serial BallPoint Mouse. When that happens, Windows loads drivers for the Serial BallPoint Mouse. This causes the cursor to move erratically about the display, clicking, right-clicking, double-clicking, dragging and dropping displayed items as it goes. On Windows 2000 and Windows XP, you may not experience the problem if you wait until after the computer is booted before connecting the GPS 19x HVS to the serial communications port. This problem is not specific to the GPS 19x HVS. Any NMEA 0183 device connected to a Windows computer's serial port is likely to cause this problem. Below are several possible solutions to this problem.

If you wish to use a different navigation software application with your GPS 19x HVS, you will need to de-select the "Binary Output Data" option that is discussed in Solution 3 below.

Solution 1: The easiest solution is to disable the Serial BallPoint mouse in the Device Manager. This solution assumes that you do not need to use a Serial BallPoint mouse with your computer. When erratic mouse movements occur, follow the steps below.

1. Unplug the DB9 connector.
2. Right-click the **My Computer** icon on your desktop and select **Properties** to open Device Manager.
3. Go to the hardware tab of the resulting pop-up window and click on the **Device Manager** button.
4. Right-click on **Serial BallPoint Mouse** and choose the option to **Disable** (NOT uninstall) this device.

Solution 2: Do not plug the DB9 connector into the computer until the computer is turned on and the operating system is completely booted up and running. Every time you use the GPS 19x HVS, you will need to start the computer and operating system before making the connection between the GPS 19x HVS and the computer. This solution usually works on Windows 2000 and Windows XP computers.

Solution 3: Change the default output of the GPS 19x HVS so that it does not automatically send NMEA 0183 data to the computer (change the default configuration to enable "Binary Output Data"). Use the Garmin Sensor Configuration Software to enable "Binary Output Data." To download the software, go to https://www8.garmin.com/support/download_details.jsp?id=4053, and click **Download**.

Please note that by enabling "Binary Output Data," the device will no longer appear as a NMEA 0183 device to your computer. As a result, mapping applications that expect to hear NMEA 0183 data will not recognize your GPS 19x HVS until you re-enable the NMEA 0183 output, disabling the "Binary Output Data" in the process.

Refer to [Appendix E: Sensor Configuration Software](#) for complete information about downloading the Sensor Configuration Software application.

After the Sensor Configuration Software is installed and running on your computer, follow the steps below to change the default data output of the GPS 19x HVS.

1. Select **GPS 19x** from the list of sensors and click **OK**. The Sensor Configuration Software opens with the default configuration file for the GPS 19x HVS, as shown on the next page.
2. Select **Config > Switch to NMEA Mode** (or press the F10 key).
3. Select **Comm > Setup** to open the Comm Setup Window.

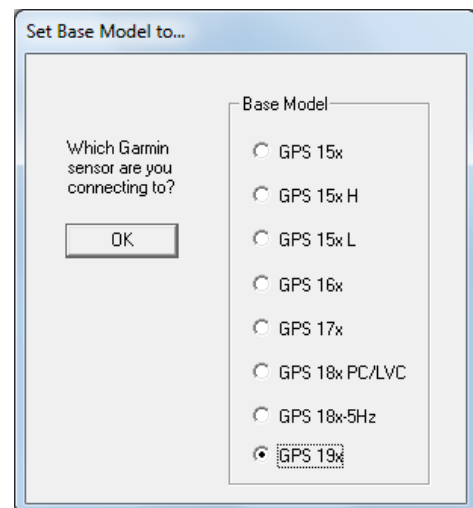

- Select the serial port to which the GPS 19x HVS is connected. Select **Auto** to have the program automatically determine the baud rate, or select **Manual** to manually select the baud rate of the GPS 19x HVS. Click **OK**

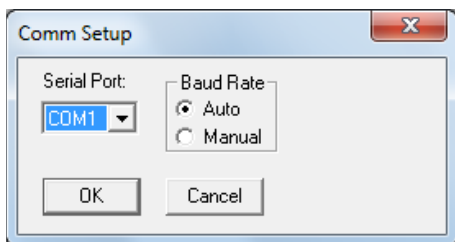

when done.

- Click the Connect icon , or select **Comm > Connect** to connect to the GPS 19x HVS.
- To view the current programming of the GPS 19x HVS, select **Config > Get Configuration from GPS** (or press the F8 key). The current programming of the GPS 19x HVS is displayed in the window, as shown on this page to the right.
- Open the Sensor Configuration Window by pressing the F6 key or selecting **Config > Sensor Configuration**.
- Place a check mark in the box next to "Binary Output Data" to change the GPS 19x HVS to Garmin Mode. The unit will keep this change in the programming until you change it again in the software.

Note: Selecting **Config > Switch to Garmin Mode** (or pressing the F11 key) only changes the unit to work in Garmin Mode until power is cycled through the unit again. For a more permanent change, refer to step 8 above.
- Click **OK**.
- When you are ready to upload the changes into the GPS 19x HVS, select **Config > Send Configuration to GPS** (or press the F9 key). The new configuration is then loaded into the GPS 19x HVS.
- You may disconnect and close the software when finished. The software configuration can also be saved for future reference.

Refer to [Appendix E: Sensor Configuration Software](#) for complete information about downloading the Sensor Configuration Software application.

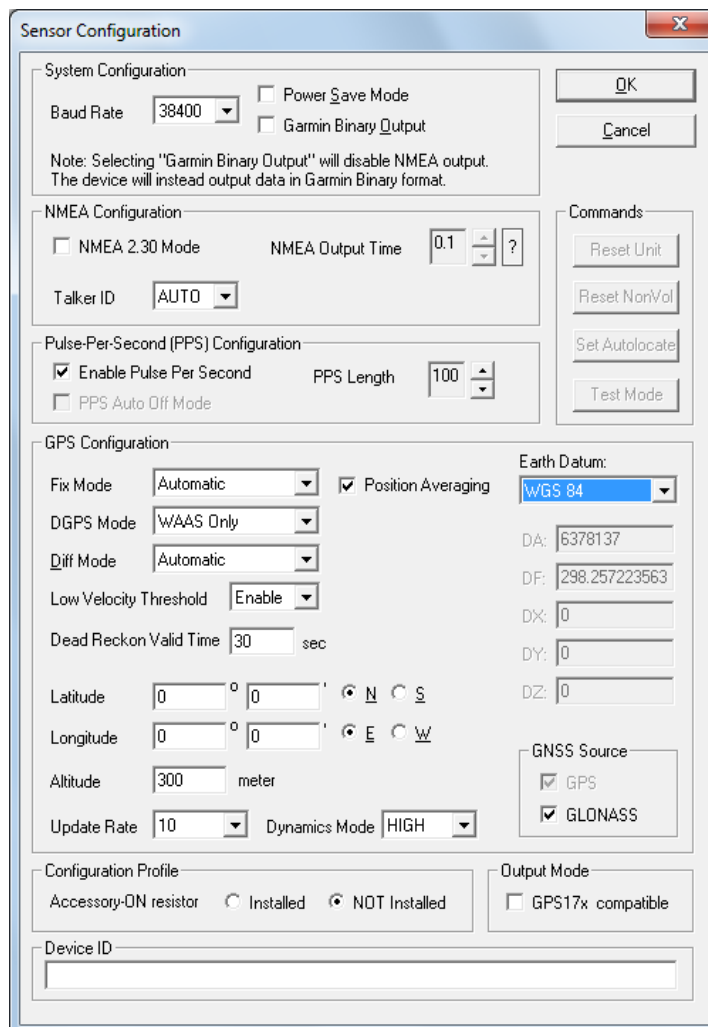
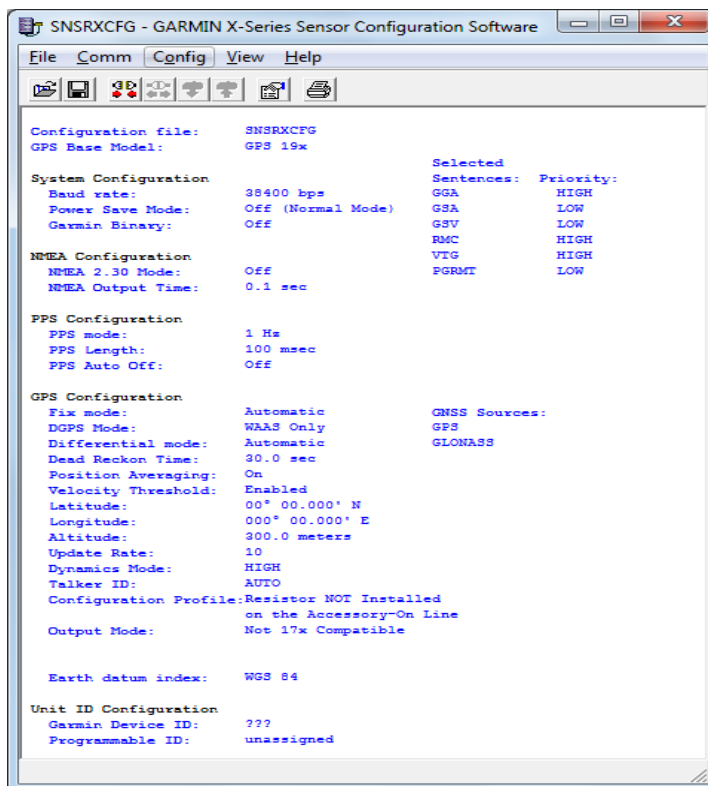

APPENDIX E: SENSOR CONFIGURATION SOFTWARE

The Garmin Sensor Configuration Software (SNSRXCFG.exe) configures the GPS sensors based on user-selected parameters. Some application features include the ability to download GPS sensor configuration, maintain different configurations in files, and perform GPS sensor configurations quickly with the use of one function key.

This section provides a brief overview of the Sensor Configuration Software. Refer to this section when using the software to configure your Garmin sensor.

Downloading the Sensor Configuration Software

The SNSRXCFG software is available from the Garmin website. To download the software, go to https://www8.garmin.com/support/download_details.jsp?id=4053, and click **Download**.

Selecting a Model

1. Double-click **SNSRXCFG.exe**.
2. Select the radio button next to the type of Garmin sensor you are configuring.
3. Select **OK**.

Connecting to the Sensor

After selecting the type of sensor, the following window opens. This is the main window for the program.

To configure your sensor, you must first connect to the sensor.

12. Select **Config > Switch to NMEA Mode** (or press the F10 key).
13. Select **Comm > Setup** to open the Comm Setup window.
14. Select the serial port to which the sensor is connected: select **Auto** to have the program automatically determine the baud rate, or select **Manual** to manually select the baud rate.
15. Click **OK**.
16. Click the **Connect** icon , or select **Comm > Connect**.
17. To view the current programming of the sensor, select **Config > Get Configuration from GPS** (or press the F8 key). The current programming of the sensor appears as shown in the example to the right.

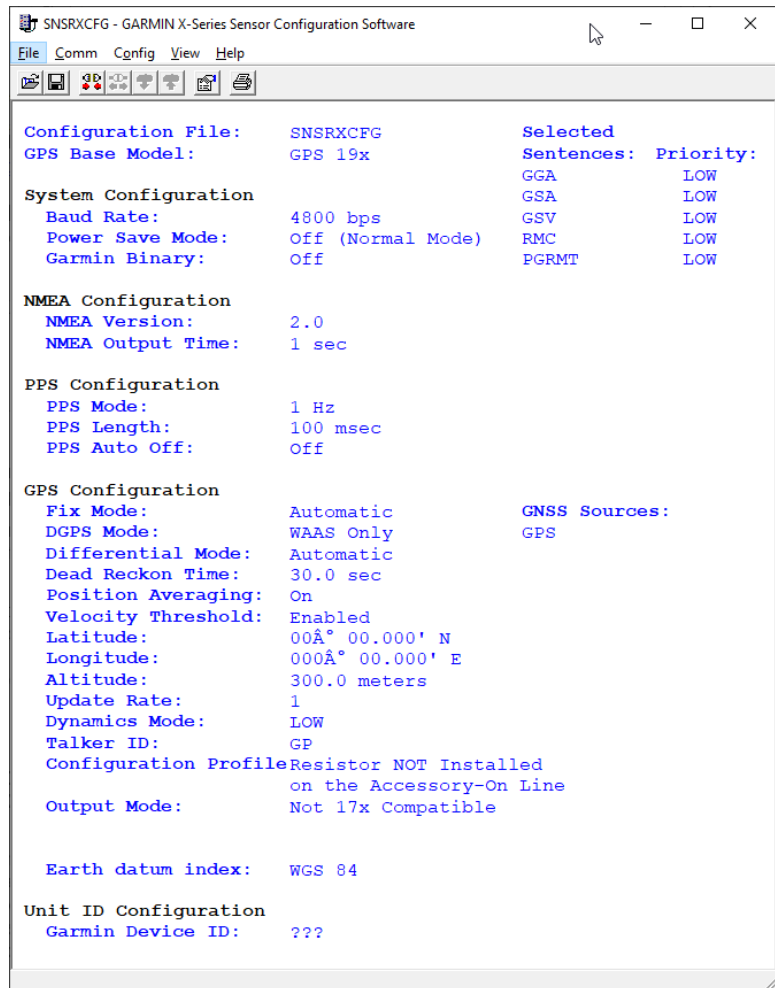

Menus

File Menu

The File Menu allows you to open, save, and print sensor configurations. The items in the File Menu work like most Windows-based programs.

Comm Menu

The Comm (Communication) Menu allows you to set the port number and baud rate, as well as connect to the sensor and disconnect from the sensor.

Setup: Opens the Comm Setup window. Select the serial port to which the sensor is connected from the drop-down list. Select **Auto** (the program determines the baud rate on its own) or **Manual** (you enter the baud rate) for the baud rate entry.

Connect: Select **Connect** to connect to the sensor in order to change or view the configuration.

Disconnect: Select **Disconnect** to disconnect from the sensor.

Config Menu

The Config (Configuration) Menu allows you to configure the sensor as it is connected.

Sensor Configuration (F6): Opens the Sensor Configuration window, shown to the right. Many of the fields in this window should not be changed. Refer to the beginning of this manual for information on many of these fields. This window is used to enter a new latitude, longitude, and altitude for the sensor. This is especially helpful when you are programming the sensor for use in a particular geographic location.

Click **Reset Unit** to perform a reset on the unit, much like cycling the power.

Resetting the non-volatile memory (**Reset NonVol**) clears all of the data from the non-volatile memory.

NMEA Sentence Selections (F7): Displays the NMEA Sentence Selections window. If the sentence is enabled, a check mark appears in the box to the left of the sentence name. Click the box to enable or disable to the sentence.

Get Configuration From GPS (F8): Retrieves the current programming from the sensor. The programming is then displayed in the Main Interface window.

Send Configuration To GPS (F9): Sends your updated configuration programming to the sensor.

Switch to NMEA Mode (F10): Switches the unit to NMEA Mode. The sensor must be in NMEA Mode when connected to this software.

Switch to Garmin Mode (F11): Switches the unit to Garmin Mode.

Update Software (F12): After you have downloaded a new software version for the sensor, you can update the sensor with the new software. Select **Update Software** and then select the file using the Open dialog box. You must locate both the .rgn file and the updater.exe file.

View Menu

The View Menu allows you to view the NMEA sentences transmitted by the sensor. You can also customize how the program looks by showing and hiding the Toolbar and Status Bar.

Help Menu

The Help Menu displays the software version and copyright information.

The screenshot shows the 'Sensor Configuration' dialog box with the following sections:

- System Configuration:** Baud Rate (4800), Power Save Mode (unchecked), Garmin Binary Output (unchecked). Note: Selecting "Garmin Binary Output" will disable NMEA output.
- NMEA Configuration:** NMEA (2.0), NMEA Output Time (1), Talker ID (GP).
- Pulse-Per-Second (PPS) Configuration:** Enable Pulse Per Second (checked), PPS Length (100), PPS Auto Off Mode (unchecked).
- GPS Configuration:** Fix Mode (Automatic), DGPS Mode (WAAS Only), Diff Mode (Automatic), Low Velocity Threshold (Enable), Dead Reckon Valid Time (30 sec), Latitude (0° 0' N), Longitude (0° 0' E), Altitude (300 meter), Update Rate (1), Dynamics Mode (LOW), Position Averaging (checked), Earth Datum (WGS 84), DA (6378137), DF (298.25723563), DX (0), DY (0), DZ (0), GNSS Source (GPS, GLONASS, BDS, GALILEO - all unchecked).
- Configuration Profile:** Accessory-ON resistor (Installed/NOT Installed).
- Output Mode:** GPS17x compatible (unchecked).
- Device ID:** (Empty text field).
- Commands:** Reset Unit, Reset NonVol, Set Autolocate, Test Mode.
- Buttons:** OK, Cancel.